

DOCUMENT RESUME

ED 213 953

CE 031 742

AUTHOR Graham, Charles D., Ed.
TITLE Pennsylvania Industrial Arts Safety Guide. Second Edition.
INSTITUTION Industrial Arts Association of Pennsylvania.; Pennsylvania State Dept. of Education, Harrisburg. Bureau of Vocational and Technical Education.
PUB DATE 81
NOTE 224p.

EDRS PRICE MF01/PC09 Plus Postage.
DESCRIPTORS *Accident Prevention; Administrator Responsibility; Developmental Disabilities; Disabilities; Educational Legislation; Equipment Maintenance; Equipment Utilization; Facility Guidelines; Federal Legislation; Guidelines; Hand Tools; Higher Education; Instructional Materials; Legal Responsibility; Machine Tools; Power Technology; *Program Development; Resources; Safety; *Safety Education; *School Safety; *School Shops; Secondary Education; Teacher Responsibility; Teaching Methods; *Vocational Education

IDENTIFIERS Emergencies; Hazardous Materials; Industrial Materials; Pennsylvania

ABSTRACT

Intended to alert industrial arts teachers, teacher educators, school administrators, and industrial arts supervisors to the importance of a strong safety program, this guide provides the instructional resources for instituting safety instruction in the public schools, for the inservice training of industrial arts teachers, and for the education of undergraduates in the teacher education programs in Pennsylvania. The material contained in the guide falls into several categories, including resources, safety information, instructional suggestions, lesson plans, materials for student use, forms and checklists, lists of responsibilities for safety programming, faculty considerations, and teacher liability. Covered in the guide are responsibility, safety laws, emergency action, safety for developmentally disabled and handicapped students, elementary industrial arts safety, hazardous materials, machine guarding, industrial materials, power technology, visual communications, instructional techniques pertaining to safety rules, equipment utilization and maintenance, materials handling, housekeeping, personal protection, facility planning, inspection checklists, and teacher liability in school shop accidents. (MN)

 * Reproductions supplied by EDRS are the best that can be made *
 * from the original document. *

ED213953

Pennsylvania Industrial Arts SAFETY GUIDE

SECOND EDITION

U.S. DEPARTMENT OF EDUCATION
NATIONAL INSTITUTE OF EDUCATION
EDUCATIONAL RESOURCES INFORMATION
CENTER (ERIC)

✓ The document has been reproduced as
received from the person or organization
originating it.
Minor changes have been made to improve
reproduction quality.

• Points of view or opinions stated in this docu-
ment do not necessarily represent official NIE
position or policy.

"PERMISSION TO REPRODUCE THIS
MATERIAL HAS BEEN GRANTED BY

Thomas R. Winters

TO THE EDUCATIONAL RESOURCES
INFORMATION CENTER (ERIC)."

Pennsylvania Department of Education

Industrial Arts Association of Pennsylvania

CE 031 742

FIRST EDITION

Prepared by the Safety Steering Committee under a charge from the Industrial Arts Association of Pennsylvania and in cooperation with the Pennsylvania Department of Education.

Committee Chairman and Editor-in-Chief

John Y. Stoudt - Instructional Leader for Industrial Arts
Norristown Area School District

Committee Members and Co-Editors

Daniel W. Irvin Educational Director
Rockwell International/Power Tool Division

Richard Long Department Coordinator for Industrial Arts
North Hills School District

Thomas V. Sebastian Vice President
Delaware Valley Safeguards Company

Michael A. Spewock Doctoral Degree Candidate
The Pennsylvania State University

Dr. Michael R. White Associate Professor
The Pennsylvania State University

Dr. Thomas R. Winters, Jr. Department Chairperson for Industrial Arts
Eastern Lancaster County School District

Earl R. Zimmerman Advisor for Industrial Arts
Pennsylvania Department of Education

Funded through Cheyney State College by Federal Vocational Education Funds through the Commonwealth of Pennsylvania, granted from Dr. John W. Struck, Vocational Education Bureau Director and State Director.

SECOND EDITION

Safety Committee Chairman and Editor

Charles D. Graham - Coordinator of Practical Arts
Colonial School District

Committee Members

Daniel W. Irvin Rockwell International/Power Tool Division
William Korns Doctoral Degree Candidate
University of Pittsburgh

Melvin E. Krug Industrial Arts Instructor
Upper Dublin School District

Richard Long Department Coordinator for Industrial Arts
North Hills School District

Thomas V. Sebastian Vice President
Delaware Valley Safeguards Company

John Y. Stoudt Instructional Leader for Industrial Arts
Norristown Area School District

Dr. Thomas R. Winters, Jr. Department Chairperson for Industrial Arts
Eastern Lancaster County School District

SECOND EDITION PRINTING FUNDED by Vocational Education Funds through the Commonwealth of Pennsylvania, granted by Dr. Jerry Olson, Special Assistant to the Secretary of Education in charge of Vocational Education.

FIRST EDITION - 1978
SECOND EDITION - 1981

DISCLAIMER

The information and materials contained in this publication have been compiled from sources believed to be reliable and to represent the best current opinion on the subject. No warranty, guarantee or representation is made by the Industrial Arts Association of Pennsylvania or the Commonwealth of Pennsylvania or contributors to this endeavor as to the absolute correctness or sufficiency of any representation contained in this publication. The Industrial Arts Association of Pennsylvania and contributors assume no responsibility in connection therewith; nor can it be assumed that all acceptable safety measures are contained in this publication, or that other additional measures may not be required under particular or exceptional conditions or circumstances.

Permission to reproduce this guide in part or in total is granted to any school or state agency personnel for the purpose of promoting industrial arts safety.

February, 1981

TABLE OF CONTENTS

INTRODUCTION 1.00

 Letter - Secretary of Education 1.01

 Letter - Governor 1.02

 Note to the Teacher. 1.03

 Acknowledgements 1.04

 Policy Statement on Safety 1.05

RESPONSIBILITY 2.00

 School Board and Superintendent. 2.00

 Safety Coordinator 2.01

 Administrator, Principal and/or Department Head. 2.01

 The Teacher. 2.04

SAFETY LAWS

 Pennsylvania Regulations 3.00

 OSHA 3.00

EMERGENCY ACTION. 4.00

 When An Injury Occurs. 4.00

 Primary Concerns 4.00

 Secondary Concerns 4.01

 Emergency Communications 4.02

 Communicating Safety to Parents. 4.02

 The Student and Safety in Industrial Arts (Memo) 4.03

 Hazardous Conditions Report. 4.04

 Accident Reporting 4.05

 Accident Reporting and Analysis. 4.05

 Accident Report Form 4.06

SAFETY FOR DEVELOPMENTALLY DISABLED AND HANDICAPPED STUDENTS. 5.00

 Civil Rights Mandate 5.00

 General Statements 5.00

 Suggested Teaching Techniques. 5.01

ELEMENTARY INDUSTRIAL ARTS SAFETY 6.00

HAZARDOUS MATERIALS 7.00

MACHINE GUARDING 8.00

 OSHA Machine Guarding Requirements 8.00

INDUSTRIAL MATERIALS. 9.00

 Compressed Gas 9.00

 Construction Processes 9.01



Dust, Fumes, and Combustible Metals.	9.02
Flammable and Combustible Liquids.	9.03
Foundry	9.05
General Metalworking	9.06
Plastics	9.07
Soldering.	9.08
Woodworking.	9.09
<u>POWER TECHNOLOGY.</u>	10.00
General Precautions.	10.00
Personal Health Considerations	10.01
Driving and Locating a Vehicle for Work.	10.02
Grease, Oil, Fuels and Solvents.	10.02
Storage Batteries.	10.03
Flammable and Combustible Liquids.	10.04
<u>VISUAL COMMUNICATIONS</u>	11.00
Drafting Room Safety Practices	11.00
Graphic Arts	11.00
<u>INSTRUCTIONAL TECHNIQUES.</u>	12.00
Safety Inspections	12.01
Safety Instructions for All Areas of Industrial Arts	12.02
Safe Practices In Care and Operation of Equipment.	12.03
Safety Rules for Power Equipment	12.04
Equipment Instruction Sheets and Evaluations	
Use of Equipment Instruction Sheets	12.05
Arc Welder.	12.06
Band Saw	12.08
Belt Finishing Machine.	12.10
Buffer.	12.12
Circular Saw.	12.14
Crucible Furnace.	12.16
Disc Finishing Machine.	12.18
Drill Press	12.20
Electric Discharge Machine	12.22
Hydraulic Training Unit	12.24
Gas Forge	12.26
Grinder	12.28
Horizontal Band Saw	12.30
Horizontal Milling Machine.	12.32
Jointer	12.34
Metal Lathe	12.36
Metal Shaper	12.38
Motorized Miter Box	12.40
Offset Printing Press	12.42
Overarm Router.	12.44
Oxy-Acetylene Welder.	12.46
Paper Cutter.	12.48

Paper Drill	12.50
Planer-Surfacer	12.52
Plastics Technology	12.54
Platen Printing Press	12.56
Radial Arm Saw	12.58
Scroll Saw	12.60
Sheet Metal Machines	12.62
Small Engine Analyzer	12.64
Spinning Lathe	12.66
Squaring Shear	12.68
Stapler and Stitcher	12.70
Tig and Mig Welder	12.72
Uniplane	12.74
Vertical Milling Machine	12.76
Wood Lathe	12.78
Wood Shaper	12.80
Safety Rules for Portable Electric Hand Tools	12.82
Portable Air Impact Wrench	12.84
Bayonet Saw	12.86
Portable Electric Belt Sander	12.88
Portable Electric Disc Sander	12.90
Portable Electric Circular Saw	12.92
Portable Electric Drill	12.94
Portable Electric Finishing Sander	12.96
Portable Electric Plane	12.98
Portable Electric Router	12.100
Hand Tool Safety	12.102
Safety Rules for Hand Tools	12.102
Housekeeping Practices	12.103
Housekeeping	12.103
Materials Handling	12.104
Electrical Safety	12.105
Fire Safety	12.108
New Fire Extinguishers Symbols	12.109
Know Your Fire Extinguishers (Chart)	12.111
<u>PERSONAL PROTECTION</u>	13.00
Eye Protection	13.01
Eye Protector Selection Chart	13.04
Lesson Plan for Eye Safety	13.05
HR 116 - The Law	13.07
Hearing Conservation Programs	13.08
Chart of Noise Sources	13.10
Respiratory Protection	13.11
Respirator Chart	13.12
Back Strains and Proper Lifting	13.11
Safe Lifting	13.13

FACILITY PLANNING 14.00
 Generally Accepted Standards and Practices 14.03
 Safety Signs 14.05
INSPECTION CHECKLIST 15.00
TEACHER LIABILITY IN SCHOOL SHOP ACCIDENTS 16.00
 Shop Practices Leading to Teacher Liability. 16.04
SELECTED BIBLIOGRAPHY 17.00
INDEX 18.00



INTRODUCTION

Effective safety education leads to attitudes and consciousness that result in safe work practices and prevent accidents within the industrial arts laboratory. In addition, effective safety education is one step in the right direction toward protecting the industrial arts instructor, supervisor, and school administrator against liability in the classroom and laboratory.

The task of overcoming the "it can't happen to me" attitude is a big one and requires that safety awareness be an integral part of the everyday instructional program. This guide is intended to serve in helping teachers develop and institute effective safety education as a part of all industrial arts instruction in the schools of Pennsylvania.

An effective safety program centers around several key considerations. These considerations are:

1. Provisions for safety instruction in all activities conducted in the industrial arts lab or classroom.
2. Supervision of students at all times in the industrial arts laboratory.
3. Documentation of safety instruction and student attendance at the time of instruction.
4. Assurance that all aspects of the industrial arts facility and its contents are safe for student activities.

This guide is intended to alert industrial arts teachers, teacher educators, school administrators, and industrial arts supervisors to the importance of a strong safety program. It is also intended to provide the instructional resources for instituting safety instruction in the public schools, for the inservice training of industrial arts teachers, and for the education of undergraduates in the teacher education programs of Pennsylvania.



COMMONWEALTH OF PENNSYLVANIA
DEPARTMENT OF EDUCATION
BOX 911, HARRISBURG, PA. 17126

THE SECRETARY

March 1981

AREA CODE 717
787.5820

Dear Educator:

"Safety above all else" should be the motto of all industrial arts classrooms. The development of good safety habits will certainly protect teachers and students at school. But just as important, the regular practice of safety becomes an attitude that lasts a lifetime.

Safety education is an important part of industrial arts instruction in Pennsylvania. As teachers and administrators, we must become more knowledgeable and teach our students to protect themselves against dangerous or potentially dangerous conditions.

This comprehensive safety guide has been carefully planned to help you achieve these goals. If the programs in this book are seriously implemented, our schools will offer the very best in safety education.

I am urging school boards, administrators, supervisors, teachers and students to adopt and follow this manual during school hours and apply its philosophy to outside activities. Let us all join together in a united effort, beginning in the classroom, to make Pennsylvanians more safety minded.

Sincerely,

Bob Scanlon

Robert G. Scanlon



COMMONWEALTH OF PENNSYLVANIA
OFFICE OF THE GOVERNOR
HARRISBURG

THE GOVERNOR

March 1981

TO: INDUSTRIAL ARTS STUDENTS

Your well being and the safety of your classmates and teachers means a great deal to the people of Pennsylvania. As Governor of the Commonwealth, and as a parent of four children, I cannot emphasize too much how important classroom safety is.

The safety habits that you develop in the industrial arts classroom will benefit you during your entire life. I encourage you to make safety your No. 1 priority as you continue your education and embark on an industrial arts career.

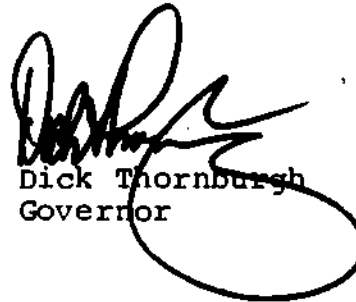

Dick Thornburgh
Governor

NOTE TO THE TEACHER

How To Use The Guide

The guide has been placed in a loose leaf binder to make it flexible and useable for the industrial arts teacher. Recognizing the continuous developments in safety education and changing laws the loose leaf binder permits additions and revisions without reprinting the entire document. All material contained in this guide may be reproduced by the teacher for use in safety instruction and for promoting safety instruction in the school. The teacher may also wish to add personal materials, lesson plans, safety instruction sheets and additional information to this binder to expand it into a complete safety program and lesson guide for the classroom.

The material contained in this guide falls into several categories. These categories are:

1. Resources
2. Safety information
3. Instructional suggestions and lesson plans
4. Materials for student use
5. Forms and checklists
6. Lists of responsibilities for safety programming
7. Facility considerations
8. Teacher liability

The individual sections of material are indexed in bold type along the edge of each page. In addition, those pages marked in the upper left hand corner with an "S" are intended to be reproduced for use with your students.

The guide is not intended to be a complete or all inclusive. It is intended to draw your attention to the necessity for safety instruction in every aspect of industrial arts and to provide you with the resources for upgrading and improving safety instruction in your classroom.

ACKNOWLEDGEMENTS

The following organizations and groups have contributed to the work of the Safety Steering Committee in the organization and writing of this guide:

California State College

Colonial School District

Delaware Valley Safeguards Company

Eastern Lancaster County School District

Industrial Arts Association of Pennsylvania

National Safety Council

Norristown Area School District

North Hills School District

Pennsylvania Department of Education

Pennsylvania State Education Association

Rockwell International/Power Tool Division

The Pennsylvania State University

Washington State Department of Public Instruction

Recognition is extended to Dr. Gary Bowman, the Industrial Arts Association of Pennsylvania funding committee chairperson, for preparing the original proposal for this project, and, to Dr. John T. Fecik, for facilitating the completion of the original document.

Special recognition is extended to Herbert Y. Bell, Supervisor, Industrial Arts and Career Education, in the State of Washington for permission to use the Washington State Industrial Arts Safety Guide as an outline for the development of this document.

POLICY STATEMENT ON SAFETY

A suggested safety education policy statement is provided below:

IT IS THE POLICY OF THE SCHOOL BOARD THAT AN EFFECTIVE INDUSTRIAL ARTS SAFETY EDUCATION PROGRAM BE CONDUCTED THROUGHOUT THE SCHOOL SYSTEM, WITH ITS PRIME OBJECTIVE BEING ACCIDENT PREVENTION IN THE SCHOOL, AT WORK AND AT HOME. IN FURTHER SUPPORT OF THIS POLICY THE SCHOOL BOARD ADOPTS THE PROVISIONS OF THE PENNSYLVANIA INDUSTRIAL ARTS SAFETY GUIDE FOR INSTRUCTION AT ALL LEVELS.

The implementation of this policy will help make young people and adults more aware of the dangers that exist about them in today's industrial technological world and of the need for attitudes and habits that will ensure safe living and conservation of human resources.

The superintendent shall be responsible for implementation of this policy and shall make necessary appointments and delegate authority to see that effective safety training and procedures are carried out at all levels within the school district. The superintendent shall see that the safety laws, codes, administrative regulations and suggested practices of the Commonwealth of Pennsylvania be followed and funded as they relate to the educational system. The staff should make extensive use of the appropriate safety guides, manuals and statutes that have been instituted and distributed by the Pennsylvania Department of Education.

RESPONSIBILITY

The school board, the administration and the instructor have the legal responsibility to provide a safe place for students to work while they are participating in industrial arts activities.

To protect yourself and your school district from liability you should be familiar with the codes and regulations applicable to your program.

To protect yourself against financial loss, liberal liability insurance limits should be carried, either through the school district policy or as an individual.

Liability insurance can vary substantially among school districts. You should be aware of the limitations of your school district liability policy.

Individual coverage may be expanded through the Pennsylvania State Education Association, other education associations or through your personal insurance agent or broker.

Safety is not a "one man show". The school board and superintendent, the district safety coordinator, the administrator (principal and/or department head), and the teacher all need to do their part.

SCHOOL BOARD AND SUPERINTENDENT

The school district controls budget, curriculum and personnel policy to a major degree. Without district level support, safety program effectiveness will at best be spotty---carried by dedicated personnel and ignored by others.

The following functions are considered the responsibility of the school board and the superintendent in a comprehensive industrial arts safety education program:

1. A policy statement similar to that shown on page 1.05 should be adopted by the board of school directors.
2. Appoint a safety coordinator for the school district and adopt a job description which reflects that responsibility. A suggested job description is on the following page.
3. Provide separate funding for facility maintenance and improvements, and safety supplies and equipment necessary to produce a safe instructional environment.
4. Provide for the inservice training of teachers in the area of safety.

DISTRICT SAFETY COORDINATOR

Each school district should have a safety coordinator. Teachers and the building administrator should rely on the district safety coordinator for assistance and consultation in their accident prevention endeavors.

The following functions are considered the responsibility of the district safety coordinator:

1. Coordinate school safety functions.
2. Set up school safety committees.
3. Provide for and participate in school safety inspections.
4. Establish a communication system to keep teachers and administrators abreast of new standards and procedures.
5. Provide for and assist in establishing teacher in-service training programs.
6. Provide for and assist in the implementation of safety instruction programs for students.
7. Provide for and assist in the investigation of and recording of accidents and injuries.
8. Research special safety problems.
9. Obtain and disseminate regulatory material (policies, guidelines, inspection checklist, posters, etc.)
10. Maintain a liason with the local governmental and industrial agencies and the Pennsylvania Department of Labor and Industry.
11. Analyze and report all accidents. See suggested accident report in this document.

THE ADMINISTRATOR, PRINCIPAL AND/OR DEPARTMENT HEAD

The individual school is the central unit of an educational enterprise. Therefore, the building principal is likely to be the administrator who is most directly responsible for the school's industrial arts laboratory safety program. If a specialized supervisor or department head functions with the principal and works directly with the teachers, some of the responsibilities for the safety program may be delegated.

The following functions are considered the responsibility of the school administrator in a comprehensive industrial arts safety education program:

1. Secure support from and maintain liaison with top school system administration.
 - a. Secure approval for the safety education program.
 - b. Secure adequate budgetary support.
 - c. Expedite building and equipment changes necessary for safe operation.
 - d. Arrange for the procurement of safety equipment.
 - e. See that appropriate staff members are kept informed of the specific maintenance requirements for safe operation of industrial arts facilities.
 - f. Carefully select industrial arts instructors for specific industrial arts knowledge and ability to establish safe practices, procedures and environment.
 - g. Arrange for administrative measures to reduce liability exposures of industrial arts staff members.
2. Provide leadership in safety program planning.
 - a. Initiate a specific program of safety education.
 - b. Set up teacher in-service training in accident prevention.
 - c. Encourage the instructional staff to maintain first aid proficiency. Require that safety supplies and emergency handling procedures are current and properly organized.
 - d. Encourage the instructional staff to be knowledgeable and proficient in the use of fire apparatus.
 - e. Instruct the industrial arts staff members in the use of this safety manual and the development of a comprehensive safety program.
3. Secure action on a program of safety education that will involve not only the industrial arts student but the entire student body.
 - a. Check periodically to make sure an adopted safety education program is in effect.

- b. Observe teachers for assurance that safety instruction is a functioning part of the course of study.
 - c. Stimulate the discovery, analysis and prompt correction of unsafe conditions or practices.
 - d. Support teachers in enforcing safety regulations.
 - e. Receive and review accident reports.
 - f. Utilize district procedures for investigating and analyzing accidents.
4. Provide safe facilities and services.
- a. Report to higher administration personnel unsafe conditions which cannot be corrected at school level.
 - b. Plan with teachers for the correction of unsafe conditions and other hazards, and for the installation of safety devices.
 - c. See that industrial arts facilities are inspected regularly for condition of equipment, and safety devices, proper housekeeping, and adequacy of exits, ventilation and material handling systems. Make necessary improvements as indicated by the inspection review.
 - d. See that safety and applicable safety regulations are specifically reviewed in the planning of new or remodeled facilities.
 - e. Provide class sizes that are in keeping with the capacity, square footage, and number of work stations available in each facility.
 - f. Provide a procedure for the removal of students who repeatedly violate established safety rules and regulations and are identified as safety hazards.
5. Secure cooperation of outside personnel and agencies.
- a. Assist teachers in locating qualified community personnel and services that can provide resources for the safety program.
 - b. Encourage qualified outside individuals to become involved in the school shop safety program.
 - c. Establish communication with parents and members of the community for developing a positive attitude toward safety and the industrial arts safety program.

THE TEACHER

The major responsibility for laboratory safety instruction in accident prevention falls on the teacher. The following are considered the responsibilities of the teacher in a comprehensive accident prevention program in school laboratories.

1. Incorporate safety instruction in the course of study and maintain documentation as to who received instruction and when instruction was given.
2. Present instruction on potential hazards and accident prevention specific to the particular school laboratory.
3. Instigate a comprehensive safety program for your particular school laboratory.
4. Develop specific safe practices, rules, and regulations relating to your facilities and provide for their enforcement.
5. Keep informed of new and accepted safe practices for accident prevention.
6. Provide proper instruction in the use of all tools, machines and equipment. Keep a record of each student's attendance, safety training, and safety evaluation.
7. Require that a student be enrolled in the industrial arts program and receive the required safety instruction prior to working in the laboratory.
8. Set a proper safety example for students to follow.
9. Insist that adequate eye protection be worn in all industrial arts laboratories at all times in accordance with Act 116 as found in this document.
10. Insist on proper protective equipment in all shop areas and require students to wear proper clothing and adequate hair guards while working in the laboratory.
11. Devise and enforce safe housekeeping procedures.
12. Insist that guards meeting accepted standards be provided and used whenever a machine is operated.
13. Establish and maintain the safest possible working environment.
14. Have set, pre-planned procedures in case of an accident or emergency.

15. Provide prompt and thorough reports of accidents including:
 - a. Written report by instructor.
 - b. Written accounts by witnesses.
 - c. Photographs of accident scene and conditions.
16. Always provide for the supervision of students in the classroom or laboratory in accordance with legal requirements.

NOTE: DON'T LEAVE THE CLASSROOM UNSUPERVISED AT ANY TIME WHEN STUDENTS ARE PRESENT.
17. Be aware of the emotionally disturbed and accident prone student.
18. Regularly review laboratory facilities to maintain safe conditions. Give special attention to:
 - a. Layout
 - b. Utilities and building services
 - c. Equipment guarding
 - d. Storage and condition of tools
 - e. Storage, labeling and handling of materials
19. Make recommendations to administrators for improving safety conditions.
20. Carry out recommendations of the administrator for improving safety instruction.

20

PENNSYLVANIA REGULATIONS

There is existing Pennsylvania legislation applicable to school safety and health. It is the General Safety Law, Act No. 174, which has been in effect since 1937. The General Safety Law contains provisions aimed at controlling specific hazards. The sections of this law most applicable to industrial arts are as follows:

Section 2. General Safety and Health Requirements

1. All establishments shall be so constructed, equipped, arranged, operated, and conducted as to provide reasonable and adequate protection for the life, limb, health, safety, and morals of all persons employed therein.
2. All belts, pulleys, gears, chains, sprockets, shafting, and other mechanical power transmission apparatus, stationary engines, electrical equipment, and apparatus shall be properly guarded to protect workers from injury.
3. All cranes, joists, steam or electric shovels, plant railroads, and other apparatus or devices used for moving, lifting, lowering, and transporting material shall be designed, constructed, equipped, and operated as to eliminate dangerous conditions.
4. The point of operation of all saws, planers, jointers or other power driven woodworking machines and all power presses, planers, shapers, and other power driven machine tools, and dangerous parts of any other machines or devices shall be provided with guards approved by the [Pennsylvania] department [of Labor and Industry]. Laundry machines, extractors, washers, ironers, and other machines or apparatus shall be provided with guards where, because of accident hazard, they are required by the department.
5. All toxic and noxious dusts, fumes, vapors, gases, fibers, fogs, mists or other atmospheric impurities, created in connection with any manufacturing process, emitted into or disseminated throughout areas where persons are employed in such quantities as, in the opinion of the department, would injure the health of employes or create other dangerous conditions, shall be removed as the point of origin, or, where this is impractical, personal protective devices shall be provided and worn by persons subjected to such hazards.
6. When employes, due to the nature of employment, are subject to injury from flying particles, falling objects, sharp or rough surfaces or materials, hot, corrosive or poisonous substances, acids or caustics and injurious light rays or harmful radioactive materials, they shall be provided with, and shall wear goggles, other head and eye protectors, gloves, leggings, and other personal protective devices (as last amended by the Act of July 13, 1953, P. L. 438).

Section 3. Lighting, Heating, Ventilation, and Sanitary Facilities

All establishments shall be adequately lighted, heated, and ventilated. Proper sanitary facilities shall be provided in sufficient number for the persons employed, and shall include toilet facilities, washing facilities, dressing rooms, retiring rooms for women, and wholesome drinking water of approved quality.

Section 5. Floor Space

The floor space of workrooms in any establishment shall not be so crowded with machinery as to thereby cause risk to the life or limb of any employe. Proper clear aisle space shall be maintained where necessary for employes to walk between machines, equipment or material. Machinery shall not be placed in any establishment in excess of the sustaining power of the floors and walls thereof.

Section 6. Removal of Guards

No person shall remove or make ineffective any safeguard, safety appliance or device attached to machinery except for the purpose of immediately making repairs or adjustments, and any person or persons who remove or make ineffective any such safeguard, safety appliance or device for repairs or adjustments shall replace the same immediately upon the completion of such repairs or adjustments.

Section 7. Prohibited Use of Dangerous Machinery

If any machinery, or any part thereof, is in a dangerous condition or is not properly guarded, the use thereof may be prohibited by the Secretary of Labor and Industry or his authorized representative, and a notice to that effect shall be attached thereto. Such notice shall be removed only by an authorized representative of the department after the machinery has been made safe and the requirement safeguards are provided, and in the meantime such unsafe or dangerous machinery shall not be used.

Section 8. Air Space for Workroom

The owner, agent, lessee, or other person having charge or managerial control of any establishment, shall provide or cause to be provided not less than two hundred and fifty cubic feet of air space for each and every person in every workroom in said establishment where persons are employed.

Also, the Pennsylvania Fire and Panic Act, No. 299, adopted in 1927, contains safety provisions pertaining directly to the facility. The basic requirement of this act is located in Section I and is as follows:

General Requirement

Every building enumerated in this act, erected or adapted for any of the purposes of several classes of building covered by the act (schools and colleges are Class D), shall be so constructed, equipped, operated, and maintained, with respect to

type of construction and materials used, fireproofing, number and type of ways of egress, aisles and passageways, stairs and fire escapes, wall openings, exits and exit signs, doors and doorways, shaftways and other vertical openings, emergency lighting, automatic sprinkler systems, fire alarm systems, fire drills, electrical equipment, inflammable and explosive materials; heating apparatus and fuel storage, number of occupants, ventilation, arrangement of seating and standing space, construction and equipment of stages, projection rooms, and dressing rooms, and all other fire and panic protection as to provide for the safety and health of all persons employed, accommodated, housed, or assembled therein...

OSHA

The Williams-Steiger Occupational Safety and Health Act (OSHA) or public Law 91-596 was passed in December 1970 and became law on April 28, 1971. As it states the law was enacted in order to:

..."assure so far as possible every working man and woman in the Nation, safe and healthful working conditions and to preserve our human resources..."

The law recognizes employee safety and health as public problems rather than private or individual concerns.

The OSHA standards contain four major categories: general industry, construction, maritime, and agriculture. Implementation is to be conducted in the following six ways:

1. Encouraging employers and employees to reduce hazards in the workplace and start to improve existing safety and health programs.
2. Establishing employer and employee responsibilities.
3. Authorizing OSHA to set mandatory job safety and health standards.
4. Providing an effective enforcement program.
5. Encouraging the states to assume the fullest responsibility for administering and enforcing their own occupational safety and health programs that are to be at least as effective as the federal program.
6. Providing for reporting procedures on job injuries, illness, and fatalities.

Pennsylvania public schools are not presently covered by OSHA because no state plan has been developed. However, many of the OSHA standards have been adopted and enforced by insurance companies and other agencies. Thus, many of the OSHA standards are being enforced even without formal adoption.

Areas of operation in which school districts can and should voluntarily attempt to comply with OSHA standards include:

1. Hand-tool, machine, and equipment safety

The design and physical condition of every item included in an industrial education laboratory must be good. Substandard items should be renovated or replaced by pieces known to be well designed and constructed.

2. Safety in working with hazardous materials

Exposure to hazardous materials must be minimized and, if necessary, eliminated. Appropriate protective equipment, such as paint masks, should be available and its use enforced.

3. Training in safety and health requirements

Teachers and students should be taught to recognize work hazards and potentially dangerous environmental conditions.

4. Fire protection

All necessary fire protection devices and services, including fire extinguishers, sprinkler systems, and fire department assistance, should be available.

5. Physical plant design

The physical plant in which an industrial arts program is carried on must be planned so that it is free of safety and health hazards. Key design features of such a structure include adequate space, proper storage of materials, a good arrangement of rooms, and an effective organization of equipment.

6. Physical plant condition

The floors, walls, partitions, ceilings, windows, doors, and other parts of a laboratory must be kept in good repair.

7. Air environment

Students and teachers must be able to work in air that is clean, fresh, safe, and comfortable. Effective heating, air conditioning, mechanical ventilation, and exhaust systems are necessary.

8. Visual environment

Natural and artificial lighting systems must be properly designed and maintained so that people working in a laboratory can see clearly and comfortably.

9. Auditory environment

Sound intensities must be kept below the level at which hearing can be damaged. Noise transmitted from a laboratory to other parts of the school must also be strictly controlled.

10. Utility service systems

Electrical, water, gas, and compressed air systems must be planned and constructed so that hazards related to the use of these utilities are minimal.

11. Housekeeping

Laboratories must be kept clean and in good order at all times. Adequate storage of materials, especially waste products, is of major importance to laboratory safety.

12. Sanitary facilities

Drinking fountains, wash facilities, and restrooms must be well designed, in good operating condition, and cleaned regularly.

13. First aid and emergency procedures

Teachers, students, and civil service employees should be trained in basic first aid and emergency procedures.

14. Class discipline

Laboratory work environments must be free of hazards that stem from poor class discipline.

EMERGENCY ACTION

Emergency situations can arise anywhere in the school environment and the procedures for dealing with these events should be developed and approved by the individual administrative unit (district or building) prior to the start of the school year. These procedures should be reviewed and revised periodically to determine their effectiveness and to make necessary modifications. The following information is provided to serve as a guide for the individual district to develop their own emergency procedures.

WHEN AN INJURY OCCURS

There are two aspects of emergency procedures. The first concern is the activities that must be done immediately following the injury. The second concern is the actions that must be taken after the confusion has subsided and the injured party is treated.

PRIMARY CONCERNS

These relate directly to the injured party and the reduction of hazard to that person. The degree of emergency care would be dependent on the injury and the qualifications of the person administering the care. If the teacher is not qualified in first aid, he/she must only do the things that will assure no further damage to the injured personnel and immediately seek trained help. This might be limited to stopping the bleeding or covering a person in shock with a blanket. Although every teacher should be trained in basic emergency first aid, many are not. Serious damage to the injured can sometimes result when they are treated by a nervous, untrained, and panic-ridden teacher. The following basic steps are recommended as the first steps when an injury occurs:

1. Determine the extent and type of injury. If this is not possible, immediately obtain professional help.
2. Restore breathing, restore heartbeat, and stop bleeding if trained in these areas; if not, send for help.
3. Apply only the first aid that is necessary to preserve life. Do no more until trained help arrives.
4. Disperse crowd and keep injured and the surrounding area as quiet as possible.
5. Notify school nurse, principal, and immediate supervisor by sending other students to these people. Do not leave the injured alone.
6. If the injury is minor, (splinter, slight cut) send the student to the school nurse accompanied by another student. Do not send the injured student alone.

7. If a foreign particle has entered the eye, seek professional help. A teacher should never try to remove something from a student's eye. If a liquid has entered the eye (acid, etc.), immediately wash the eye in an eye wash and contact the nurse.
8. Notify parents and school officials.

It is the responsibility of the teacher to know what to do in case of an accident and also to know what not to do. This kind of information is best obtained through a variety of first aid courses offered through the Red Cross or other agencies. The first few seconds or minutes of a pupil's injury are sometimes the most critical and the action or inaction that the industrial arts teacher may take could be crucial to the student's life.

SECONDARY CONCERNS

When the injured student has been administered to by professional help (nurse, ambulance crew or doctor) the concerns of the teacher are focused on the remaining students and the follow-up procedures in regards to the injury. Some action is necessary in the following areas:

1. Calm the other members of the class. Restore the situation to a safe environment. If the accident was serious, discontinue instruction for the period. The students will be too upset to perform effectively and may in fact be "accident prone" due to the accident.
2. Complete accident report in triplicate; one for school nurse, one for the principal and immediate supervisor, and one for the teacher's permanent file (to be retained until the injured pupil reaches age 21 or if the pupil is a special education student, retain permanently).
3. Analyze cause and effect of the accident and make written recommendations to the principal for corrective measures to be taken. (Retain a copy of this communication and subsequent action.)
4. Review and record safety practices, procedures, instruction, and student evaluation concerning the cognitive, psychomotor, and affective instruction that was delivered, and was intended to prevent this type of accident from happening.
5. Check on the results of the treatment of the injured pupil.
6. Follow-up in your classes with a discussion and instruction regarding the safe practices that were violated and contributed to the accident.

The procedures mentioned should also be followed for "almost accidents" to assure that the conditions that almost caused an accident are treated and eliminated from the laboratory environment.

EMERGENCY COMMUNICATIONS

Procedures established for emergency situations and accidents must contain the approved method of "who tells what to whom and when." To facilitate this communication, each industrial arts room should have access to a telephone with a direct outside line (for ambulance, fire, and police emergencies.) In addition:

1. All students should know the location of the telephone and be familiar with the emergency procedures and numbers.
2. All personnel in the laboratory should have access to the phone for emergency communications. (The telephone should not be locked in the teachers office.)
3. Emergency procedures and police, ambulance and fire department numbers and the procedure for dialing an "outside" line should be posted at each phone location.

COMMUNICATING SAFETY TO PARENTS

For years, industrial arts teachers have used "permission slips" to be sent home and signed by the parent permitting their child to participate in the shop program. Many teachers believed that this "permission slip" relieved them of some or all of their responsibility and liability should an accident occur. IT DOES NEITHER OF THESE. The purpose of this type of communication is to:

1. Inform the parent of his/her child's participation in industrial arts type activities.
2. Outline the safety instruction and procedures that are followed by the teacher and the district.
3. Obtain from the parent relevant information regarding any health problems that may have a bearing on their child's performance.
4. List the parent's and telephone number(s) where they can be reached during school hours and list the name of their family doctor.

An illustration of what this communication to the parents might look like is included on the following page.

THE STUDENT AND SAFETY IN INDUSTRIAL ARTS

_____ School District
Industrial Arts Department
School: _____
Teacher: _____

To: _____
Parent or Guardian

_____ is enrolled in our industrial arts program
(Name of Student)
and will have the opportunity to use various tools and equipment. Appropriate instruction in the safe operation of these tools and equipment is given and close supervision is maintained at all times. Although every precaution is taken to prevent accidents, a certain risk is involved due to the nature of the experience, the age of the student, and the learning environment.

We are asking your cooperation in impressing upon your child, the importance of being careful. This we believe will back up the instruction that is given in school.

We welcome your visit to our school and the industrial arts department to see our program. These visits can be arranged by calling _____.

Thank you very much for your help and assistance in providing your child with the "real world" experience of industrial arts in a safe working environment. I have read the attached communication and I understand the type of program that _____
(Student Name)

is enrolled in. I will stress the safety aspects of this program to my child. I encourage my child to participate fully in this industrial arts program.

(Signature of Parent or Guardian) Date

Phone _____ (Home) _____ (Work)

Please identify any health problems which may have a bearing on your child's participation in this class.

I agree to observe all safety rules and procedures for safe operation and conduct in the school industrial arts shop and will wear approved eye protection at all times while in the laboratory in accordance with state law.

Signature of Student Date

HAZARDOUS CONDITIONS REPORT

This is a suggested method for reporting the hazard and directing action to see that the hazard is corrected or removed.

If a hazard exists, the operation should be "red tagged" and shut down until corrected. (NOTE: THIS FORM CAN BE USED TO REPORT A STUDENT WHO IS A HAZARD AS WELL AS A HAZARDOUS CONDITION IN THE LABORATORY).

HAZARDOUS CONDITIONS REPORT

DATE _____

TO: _____
(Building Administrator) (Position) (School)

Description and Location of Health or Safety Hazard:

Suggested Solution:

Teacher Signature: _____

- Distribution: Original - Building Administrator
- 1st Copy - Department Chairperson
- 2nd Copy - Teacher Reporting Hazard
- 3rd Copy - District Safety Officer

Action Taken:

By whom: _____
(Signature)

ACCIDENT REPORTING

Any accident that occurs during industrial arts activities and in the industrial arts shop must be reported. This applies to after school accidents as well as those during the school day. Any accident, even a slight cut, must be reported since this indicates corrective action that must be taken by the teacher, administrator, or both.

A form for the reporting of these accidents can be adapted from the one on the following page. This report should be completed in triplicate; one for the principal, one for the school nurse, and one for the teacher's permanent file.

ACCIDENT REPORTING AND ANALYSIS

1. Require students to report all accidents to the teacher, regardless of nature or severity.
2. Keep a record of all industrial arts accidents resulting in injury to students, regardless of nature or severity.
3. Analyze all accident reports for the purpose of aiding in the prevention of other accidents.
4. Use your school district's printed or duplicated form to record the details of accidents and forward to the appropriate personnel.

INDUSTRIAL ARTS DEPARTMENT

Student Accident Report

TO BE COMPLETED BY INSTRUCTOR

Student Name _____ Grade _____

Location of Accident _____ Time _____ A.M. _____ / _____ P.M.
(Lab Area)

Date of Accident _____

Description of Injury _____

Location of Instructor when Accident Occurred: _____

Description of How Accident Happened: _____

Indicate Equipment, Machinery, or Tools Involved: _____

Describe unsafe practices, if any, contributing to accident: _____

Suggestions for prevention of similar accident: _____

Witnesses to Accident: 1. _____

2. _____

Instructor's Signature _____ Date _____

Student's Signature _____ Date _____

NOTE: One Copy to be filed with Department Chairman

SAFETY FOR DEVELOPMENTALLY DISABLED
AND HANDICAPPED STUDENTS

CIVIL RIGHTS MANDATE

The Rehabilitation Act of 1973, Section 504 was initially enacted into law to protect the civil rights of all handicapped Americans. The implementation regulations and enforcement provision did not become law until June 1977. Now, however, it provides greater opportunities for physically or mentally handicapped individuals.

The basic requirements of the law are summed up in the following section:

GENERAL PROVISION AGAINST DISCRIMINATION
Section 84.4

Any program or activity which receives federal financial assistance (1) may not exclude qualified handicapped persons from aids, benefits or services; (2) must provide equal opportunity to participate or benefit; (3) must provide services as effective as those provided to the nonhandicapped, and (4) may not provide different or separate services except when necessary to provide equally effective benefits.

Services need not be identical to those provided to the non-handicapped, but must be the equivalent to them and must afford an equal opportunity to achieve results in the most integrated setting appropriate to the persons "needs."

Mainstreaming is the result generally associated with Section 504. It puts students in a "least restrictive environment," usually a regular classroom or lab situation. When one or two special needs students are mainstreamed into a regular class, special safety considerations and/or precautions must be taken by the teacher. Such situations will have to be adapted to the individual needs of the student and the program.

GENERAL STATEMENT

The responsibility for safe working conditions in a school laboratory is the prime concern of the teacher and all the students who work in the facility. With this in mind, the instructor of industrial arts subjects should make a special effort to teach safety to the disadvantaged and handicapped students enrolled in his or her program. Many special students such as these will need added instruction in safety with emphasis on personal responsibility to themselves and others with whom they work. Initially, instruction should be given in a classroom setting for short period using an abundance of visual aids to explain proper safety procedures. Small group demonstrations can also be very effective while using the actual machines and tools. Individual instruction should follow the small group demonstrations before the students actually use the equipment in the laboratory. In addition, safety

reviews should be repeated at intervals to help reinforce safety procedures.

Industrial arts teachers must be alert at all times during the working sessions for unsafe conditions and actions by the special students, and should be ready to take remedial steps if needed. Other sections of this manual list specific safety procedures and lessons that the teacher should follow to instill safe working habits in the student with special needs.

SUGGESTED TEACHING TECHNIQUES

1. Be sure that eye protection is worn. Have the students remind each other that safety glasses must be worn.
2. Check out each student on the power tools that he or she is about to use. Review the safety rules from time to time with each student -- especially after a vacation or prolonged absence of the student. Be sure to document the reoccurrence of this instruction.
3. Medical records should be checked to determine if any special students are subject to seizures, fainting spells, etc. If the teacher finds someone who has one of these conditions, that individual should be given additional monitoring while using all equipment.
4. Make students aware of the potential dangers of cleaning agents, cutting fluids, solvents, thinners, lubricants, etc.
5. Remind students periodically of the importance of keeping work areas clean and free of hazardous objects.
6. Usually there is not a problem of horseplay by special students in a shop class unless they are encouraged by other students. The amount of horseplay will depend on the professional personnel and the rules established for the laboratory. If students are kept busy and supervised, horseplay for the special student is no major problem.
7. Isolation of a special student when rules of the laboratory are violated has been found to be one of the most effective methods of discipline. Keeping the student separated from the rest of the group should last no longer than one class period.
8. Special students have a tendency to wander about the laboratory area. They must understand that they have an area to which they are assigned and must stay there.
9. Testing of the special student's abilities should be done by continual observation by the teacher, and demonstration by the student. Evaluation should not be limited to tests requiring reading, writing, and comprehension.

10. The teacher should design jigs and fixtures that serve to promote a higher level of student success while using tools and machines.
11. Communication between teacher and student may be enhanced by using devices that improve reception and expression of information. Amplifying and magnifying stimuli, whether coming in or going out, are important considerations.
12. Individualize the program of instruction as much as possible to modify the instructional method to meet the needs of the student.
13. Plan to reserve a portion of your facility that can be made free from noise, physical stimuli, and visual stimuli. This may help those students who are easily distracted by them.
14. Minimize access barriers to sinks, tool cabinets, doorways, machines, workbenches, shelves, desks, etc.
15. Accept the child as he or she comes to you. Keep in mind that the student's success depends not only upon his or her own characteristics and abilities, but also upon the teacher's attitude and the quality of the learning environment.
16. Employ the aid of the special education resource people on your school staff. These people are specialists who can provide you with valuable information in dealing with the problems of the special needs students enrolled in your program.
17. Keep in mind, that special needs students respond very favorably to frequent verbal praise and reinforcement. A non-reading "hands-on" environment may provide some real positive feelings of success for them through this praise, and also by seeing their finished products.
18. Encourage heterogeneous grouping with the classroom. Placing the special student within a small group of students with various abilities will provide him with models for behavior in a laboratory or other industrial-type facility.

ELEMENTARY INDUSTRIAL ARTS SAFETY

Part of an elementary industrial arts program provides an opportunity for students to gain familiarization with a variety of tools, materials, processes, and products. This in turn requires that safety be included as an integral part of that program.

Safety should be the primary consideration in all lesson planning and work activities. Developing a positive attitude toward safety is imperative for students at this age. Safety habits developed now can be utilized both in and out of school for an entire lifetime.

The following safety suggestions are provided for the elementary teacher as a basic listing of items that should be included in their program. This is not to be considered an all-inclusive list. It will vary depending upon the types of equipment and materials used, the complexity of the elementary program, and the teaching techniques employed.

1. Provide eye protection and require that it be worn by all children. This is required by Pennsylvania Act 116. Soft vinyl monogoggles or mini-goggles are preferred by elementary children.
2. Instruct children on the safe and proper use of tools prior to an actual activity. Do not assume that students know how to safely use any hand or machine tool.
3. Show children how to carry sharp or pointed tools safely.
4. Provide adult supervision on a one-to-one basis when elementary children use power tools such as a saber saw, electric drill, or a dremel jig saw.
5. NEVER leave the classroom unsupervised at any time.
6. When possible provide a jig or fixture to hold the work so a child has both hands free to hold the tools.
7. Key switches on machines or a locked master panel switch should be provided for those times when power tools are not to be used.
8. Use non-toxic materials on the objects produced.
9. Develop and enforce good housekeeping procedures. Clean, clutter-free facilities provide safe working conditions.
10. Use tools and equipment that are the proper size for the age and size of the children using them.
11. Impress upon children the necessity for reporting all injuries, regardless of the severity.

HAZARDOUS MATERIALS

The following is a listing of some of the hazardous substances encountered in the school shop. Some are more dangerous than others; however, all should be treated with respect and used properly. If additional information is needed on these or any other materials, contact the manufacturer. They frequently can provide information concerning the hazards of a substance, precautions to be observed in handling and storing, and emergency first aid procedures.

Hazardous Substance	Protection
ADHESIVES	
Synthetic adhesives containing formaldehyde, neoprene, and epoxy resins may cause skin and respiratory problems.	Ventilation systems and personal protective devices (gloves, respirator) can be used.
AMMONIA	
Ammonia has a characteristic odor and a sharp taste. It is used as a cleaning agent and refrigeration gas. Skin contact causes burns, and the vapors will irritate eyes, nose, and throat.	Local exhaust systems and protective clothing should be used with ammonia. Also clean running water should be available for eye wash and showers.
ASBESTOS	
Exposure to asbestos can occur where extensive brake lining is being done.	Exposure should be limited by ventilating all dust-producing operations and wetting materials before handling. Special clothing and approved respirators should be used when handling asbestos.
Inhalation of excess asbestos fibers for a long period of time can result in asbestosis and possible cancer.	
PRODUCTS OR OPERATIONS INVOLVING ASBESTOS SHOULD BE AVOIDED IN THE SCHOOL SHOP.	
CAUSTICS AND CORROSIVE CHEMICALS	
Sodium hydroxide is a caustic used in a cleaning dip tank. Skin contact will cause severe burns.	Rubber gloves, a face shield, and other protective clothing should be worn. Any skin contact with caustics should be washed off immediately with clean water.

Health Hazard Substance

Protection

CUTTING FLUIDS

Cutting fluids, their additives and oils, can cause contact dermatitis, or skin irritation. Also, prolonged irritation of cutting oil mists can cause irritation of the mucous membranes of nose and throat.

Skin contact should be avoided, or gloves worn. Hands should be washed thoroughly with soap and water after any contact.

EPOXY RESINS

Wet or uncured epoxy resins can cause skin irritation when contacted. Respirator problems, headaches, and nausea may result from breathing the vapors or dust.

Ventilation must be provided to reduce the vapors. Appropriate gloves and protective clothing may also be worn.

ETHYLENE DICHLORIDE (EDC)

EDC SHOULD NO LONGER BE USED as an acrylic solvent. It has been proven to be a cancer causing agent and was removed from the market.

Provide adequate ventilation or better still, discard the material.

FORMALDEHYDE

Formaldehyde has a distinct pungent odor. It is irritating to the skin and mucous membranes as well as the eyes. Medium exposure can cause respiratory problems, and prolonged exposure may increase the incidence of cancer.

Proper ventilation should be used with formaldehyde or products using formaldehyde. Protective clothing can be used to prevent skin contact.

HYDROCHLORIC ACID

Hydrochloric acid causes severe burns when in contact with the skin. The vapors are also irritating when inhaled.

Protective clothing and eye protection should be used. Proper ventilation is also necessary. Eye wash fountains and showers should be available.

METAL FUMES

Such fumes are generated from torch-cutting, welding, or foundry operations, and can cause respiratory problems. Alloys of toxic metals can cause severe health problems.

Exhaust ventilation is necessary for all of these operations. Proper eye protection and possibly respirators, should be used.

Hazardous Substance

Protection

PAINTS, LACQUERS, STAINS, AND SOLVENTS

Thinners in these finishes have a narcotic effect on workers over a long period of time. They can cause lung and liver damage. Skin rashes and irritation are also caused when chemicals and thinners come in contact with the skin.

Proper ventilation when staining or painting is necessary. Solvent-resisting gloves and long sleeved shirts should also be worn.

SULFURIC ACID

Sulfuric acid will cause severe burns of the eyes and skin upon contact. Vapors will also cause inflammation or possible damage to the respiratory tract and lungs.

Proper exhaust ventilation must be provided when using sulfuric acid. Rubber gloves and other protective clothing should be used to avoid skin contact. Respirators may also be used if needed. Eye wash fountains and showers should be available.

ULTRA-VIOLET RADIATION

Ultra-violet radiation from lamps or welding can be harmful to the skin and eyes.

Eye protection and protective clothing--long sleeves should be used.

ZINC OXIDE FUMES

Fumes from zinc oxide inhaled in excess may cause an illness known as "metal fume fever." The symptoms are similar to those of the flu, occur a few hours after exposure, and usually last less than 24 hours.

Plenty of ventilation should be provided when cutting or welding galvanized steel.

MACHINE GUARDING

Machine guarding is one of the most important safety considerations in a shop. Proper guarding will allow the worker to work safely as well as perform assigned tasks.

Specific guarding methods are not necessarily preferable to others, but the physical layout, type of operation and material limitations may require using certain types of guards. Any guard should not itself become a hazard.

There are three main types of machine guards.

1. Enclosure Guards

Full enclosure guards are preferred to all other types because access to dangerous parts is prevented. Flying or breaking parts can also be contained with this type of guard.

2. Interlocking Guards

An interlocking guard should be considered the first alternative if a full enclosure guard is not practical. An interlocking enclosure guard may be opened or removed as needed. However, there is usually an electrical interlock which makes the machine inoperable while the guard is open.

Another type of interlocking or barrier guard uses a bar or electric eye which, when tripped, stops the machine.

3. Automatic Guards

The automatic guard works independently of the machine operator, as long as the machine is in motion. Common types of automatic guards are sweep and pushaway devices. This type of guard removes the operator's hand or arm from the danger zone.

OSHA MACHINE GUARDING REQUIREMENTS

Listed below are some of the more common OSHA guarding requirements that apply to the school shop. For additional requirements or more specific information refer to the appropriate sections of the OSHA regulations.

1. The guard must be affixed to the machine, if possible.
2. Fans less than seven feet above the floor or working level must be guarded with mesh openings not more than one-half inch across.

3. Machines designed for a fixed location must be securely anchored.
4. All V-belts and chain drives must be completely enclosed.
5. Machines must not start automatically when power is restored after a power failure.
6. Shield the feed rolls or other movable parts of feeder attachments to protect the operator.
7. Table saws must have a hood (guard) that completely covers the saw blade at all times.
8. Except for grooving, dadoing, or rabbeting a spreader and non-kickback fingers or dogs must be provided on a table saw.
9. Radial arm saws must have an upper hood that encloses the top portion of the blade. The sides and lower portion of the blade are guarded to the full diameter with a device that automatically adjusts to the thickness of the stock.
10. Anti-kickback fingers are also required on a radial arm saw.
11. Direction of saw blade rotation must be clearly marked.
12. Band saws must be completely enclosed except for the portion from the bottom of the guide rolls to the table.
13. Jointers may not have a knife projecting more than 1/8 inch beyond the cylinder head.
14. Jointer guards must automatically adjust themselves to cover all sections of the head on the working side of the fence and remain in contact with the work at all times. The section of the cutter head back of the fence must also be guarded.
15. Cutting heads on wood shapers must be enclosed with a cage or adjustable guard at least as great as the diameter of the cutter.
16. Feed rolls on a planer must be guarded by a hood or suitable guard to prevent the operator's hands from coming in contact with the in-running rolls.
17. The blade of a portable circular saw must be guarded above and below the base plate or shoe.

18. When the portable circular saw is withdrawn from the work, the lower guard must automatically and instantly return to a covering position.
19. Disc sanders require an enclosed disc except for the portion of the disc above the table.
20. Belt sanders require guards at each nip point where the sanding belt runs onto a pulley. The unused portion of the sanding belt must be guarded against accidental contact.
21. Wood lathes used for turning long pieces of stock held only between the two centers must have long curved guards extending over the top of the lathe to prevent the work pieces from being thrown out of the lathe, if they become loose.
22. The tops and sides of the router must be covered.
23. Wheel safety guards must cover the spindle end, nut, and flange of a grinder.
24. The exposed area of a grinding wheel should not exceed more than one-fourth of the area of the entire grinding wheel.
25. Hand held electric power tools must be equipped with "dead man" or "quick-release" control so that the power can be shut off when the operator releases the control.
26. All hand-held portable electric equipment must have its frame grounded or be double insulated and identified as such.
27. The rated load of any jack must be permanently marked on it.
28. All roller-type printing machines must be equipped with nip guards.
29. Each employer shall be responsible for the safe conditions of tools and equipment used by employees.

INDUSTRIAL MATERIALS

COMPRESSED GAS

The most commonly used gases for cutting and welding are oxygen and acetylene. However, you may also be using hydrogen, nitrogen, MAPP gas, argon, helium, freon, ammonia, propane, carbon dioxide, or sulphur dioxide in some of your projects. To use them safely, you should be aware of the following:

1. Always know the characteristics of the gas you are using.
2. Read the label of each cylinder. There is no standard color code for compressed gas bottles.
3. Treat compressed gas cylinders with respect. Careless handling may result in valve or cylinder damage and can produce instant death for you or your companions.
4. Students must not move cylinders without the use of a hand cart.
5. All compressed gas cylinders must be kept upright when in use.
6. Be sure that hoses, valves and regulators are tightly secured and in good repair.
7. Shut off valves and regulators when not in use.
8. Store spare gas cylinders in a well ventilated area separated by a fire resistant barrier---preferably outdoors.
9. When moving or storing cylinders, cylinder caps must be in place.
10. Never use oil on any oxygen valve or regulator equipment.
11. Always have your instructor check your set-up before opening any valve.
12. Always work in a well ventilated area.
13. All gas cylinders must be secured and stored erect at all times.

CHARACTERISTICS OF GASES IN COMMON USE							
GAS	COLOR	ODOR	WEIGHT COMPARED TO AIR	FLAMMABLE	EFFECT WHEN BREATHED	PHYSICAL STATE WHEN SHIPPED	REMARKS
ACETYLENE	None	Garlic-like	Lighter	Yes	Anesthetic	Dissolved	Wide explosive range when mixed with air or oxygen
COMPRESSED AIR	None	None	Same	No	None	Gas	Supports combustion
AMMONIA	None	Pungent	Lighter	Yes	Irritant	Liquid	Does not support combustion
ARGON	None	None	Heavier	No	None	Gas	Does not support combustion
CARBON DIOXIDE	None	Faint	Much heavier	No	None	Liquid	Does not support combustion
CARBON MONOXIDE	None	Faint	Lighter	Yes	Asphyxiant	Gas	Supports combustion
CHLORINE	Greenish-Yellow	Disagreeable	Much heavier	No	Irritant	Liquid	Not explosive/flammable; will support combustion.
FREON - 12	None	None	Heavier	No	None	Liquid	Does not support combustion
HELIUM	None	None	Much lighter	No	None	Gas	Does not support combustion
HYDROGEN	None	None	Much lighter	Yes	None	Gas	Wide explosive range when mixed with air or oxygen
METHYL BROMIDE	None	Pungent	Heavier	No	Irritation Intoxication Nausea	Liquid	Does not support combustion
METHYL CHLORIDE	None	Ether-like	Heavier	Yes	Anesthetic	Liquid	Explosive when mixed with air or oxygen
NITROGEN	None	None	Slightly lighter	No	None	Gas	Does not support combustion
OXYGEN	None	None	Slightly heavier	No	None	Gas	Supports combustion
PROPANE	None	None Artificially odorized	Heavier	Yes	Intoxicant	Liquid	Flammable
SULPHUR DIOXIDE	None	Disagreeable	Much heavier	No	Irritant	Liquid	Does not support combustion

CONSTRUCTION PROCESSES

Construction processes usually require a large amount of materials handling in addition to the usual hand tool and machine tool operations. According to the National Safety Council, nearly one in four disabling injuries is directly related to materials handling activities. These accidents include such things as slips and falls while carrying objects, back injuries and hernias from improper lifting practices, chemical and heat burns from failure to use protective clothing and equipment, and mangled or amputated fingers or toes from dropped objects.

Some of the things you can do to reduce the chance of injury to yourself or others when handling materials are:

1. Use proper aids to handle the materials, such as tongs for hot materials, block and tackle or jacks to lift extra heavy items, and blocks or wedges to keep items from rolling.
2. Don't try to lift heavy objects without help; before you lift, make sure who is giving the order.
3. Use proper lifting techniques.
4. If the material is heavy or sharp, use gloves or pads to assure a better grip or to avoid cuts. Be careful of splinters when handling lumber; wear gloves to handle rough lumber.
5. Before you pick up an object, make sure that the path you intend to follow is unobstructed.
6. With heavy objects, make a first lift before carrying it so that you can get the feel and position.
7. With long objects, such as pipe or ladders, have someone at each end so that the object can be safely guided.
8. Be careful not to drop or set heavy objects on your feet or those of other people.
9. Stack materials so there is no danger of slipping or falling during storage or removal.

Many construction processes require the use of portable power tools. With this in mind, it is wise for the student to be aware of the following safety rules for portable electric tools. (Consult the handouts on safety rules for portable electric tools included in this document.)

DUSTS, FUMES, AND COMBUSTIBLE METALS

Dust or fumes found in the industrial arts laboratory can be irritating to some people. Some can be highly flammable or explosive and possibly cause serious or permanent illness. It is important to control classroom exposure by:

1. Use adequate ventilation equipment to remove dusts from your work area.
2. Sweep or vacuum to properly dispose of dusts produced from manufacturing processes.
3. Wear an appropriate respirator when working on dust producing operation. (See respirator chart.)

4. Consult your instructor before cutting, welding, or grinding on galvanized metals.
5. Asbestos dust is a particular hazard that requires extra precaution when cutting, drilling, or machining. Wear appropriate respirators and protective clothing if you must work with this material. Do not use asbestos if at all possible.
6. Metals such as magnesium are very unstable and should not be used in the industrial arts laboratory.
7. When working with lead or zinc, whether burning, welding, soldering, melting, or machining, good ventilation is essential.

FLAMMABLE AND COMBUSTIBLE LIQUIDS

1. Always read the label on the container before using any of these materials.
2. Be sure that the exhaust fan or ventilation vents are operating in the area where flammable liquids are stored.
3. Draw out only as much liquid as you will need during your class period for a particular operation.
4. Dump waste or excess materials only into covered metal containers as directed by the instructor.
5. Use a funnel when pouring into a small container.
6. Read and follow instructions for handling and mixing catalysts with resins and finishes.
7. Never pour catalysts back into the bottle.
8. Always add catalyst to resin, not resin to catalyst.
9. Never apply resin, paint or other finishing material near areas used for flame cutting, welding, grinding, soldering, or other hot work.
10. Be sure that your work area is well ventilated.
11. Store thinners and solvents only in original purchase containers or approved cans.
12. Wear rubber gloves to minimize chances of skin irritation.
13. Wash hands and other exposed skin areas before leaving the shop.

14. Remove any article of clothing that may have become accidentally soaked with epoxy, polyester resins, and other potentially dangerous substances.
15. Make sure that your finishing area is protected with a fire extinguisher in good working order. Be certain that the extinguisher contains the proper extinguishing agent for flammable and combustible liquids. (See Chart)
16. If a respirator is needed consult instructor to see what respirator should be used.

Some of the more hazardous flammable liquids that you may encounter in your shop activities are (listed in approximate order of hazard):

1. starting fluid
2. gasoline
3. aerosol cans**
4. catalysts* like M.E.K. Peroxide
5. carburetor cleaner
6. acetone
7. lacquer thinner and lacquer
8. adhering liquid (for silk-screen process)
9. paint thinner
10. alcohol
11. shellac
12. japan dryer*
13. kerosene
14. paint
15. resin (polyester)
16. stain and varnish
17. danish oil

*These materials could accelerate spontaneous combustion or could react violently when mixed with organic material. (Consult your instructor before use.)

**The hazard could vary greatly depending upon the propellant used in the can. (Consult your instructor before use.)

FOUNDRY

Safe practices in foundry areas must be observed at all times. Mishandling of molten metal can cause serious burns that may result in permanent disability.

1. Wear proper protective clothing when handling molten metal; safety glasses and face shield or helmet, apron, leggings and approved gloves. Tennis shoes or sandals are not acceptable.
2. Always treat crucibles, flasks, castings and other equipment as if they are hot; determine if they are hot before picking them up.
3. Ask your instructor to check your mold before closing it. Be sure it is not too damp before pouring - it could explode.
4. Keep flammable materials away from the foundry area -- paints, solvents, etc.
5. Light the furnace only when supervised by your instructor. Follow the manufacturer's directions and the posted procedure for lighting the furnace.
6. Before removing crucible, shut off the gas first, then the air. Use a crucible lifter to remove crucible from furnace.
7. Carry molten metal as close to the floor as possible using a two-man pouring tool.
8. Keep water and wet items away from the pouring area of the foundry. Moisture and molten metal can cause an explosion.
9. The foundry pouring area floor should be protected with sand to prevent accidental "floor explosions" caused by spills of molten metal.
10. In consumable pattern casting (styrofoam), keep the sprue basin filled to prevent firing; turn on foundry room area vent fan; do not breathe fumes.
11. In hot shell or CO₂ shell molding, the two halves of the mold should be securely fastened and banked in a flask of green sand to dissipate heat; do not breathe fumes.

1. Keep your work area free from scraps of metal stock.
2. Keep metal cutting tools sharp.
3. Make sure that hammer heads and screw-driver blades are fastened tightly to their handles.
4. Always put a handle on a file before you use it.
5. Grind mushroom heads and all burrs off cold chisels, center punches and other small hand tools.
6. Never carry tools in your pockets.
7. Never try to hold a piece of metal in your hand while it is being machined. Use a fixture or a clamp to hold the workpiece.
8. Keep tools and machines clean and in good working order during use and after use.
9. Sheetmetal is sharp. If you are scratched or cut, get first aid immediately. Don't laugh off a small injury. Infection may start many days after you scratch your hand.
10. A clean shop is a safe shop. Don't "wait for George to do it."
11. Wear appropriate gloves when handling hot metals.
12. Always wear eye protection. A sliver of metal in the eye can cause blindness. Don't think that it can't happen to you. Each year, there are over 64,000 eye injuries in school and industrial shops. Don't add to this number.
13. Get rid of waste materials properly.
14. Put away tools and accessories. Clutter causes accidents.
15. Exercise caution when using portable hand tools, spot welders, electric shears and the like. These tools operate on at least 110 volts of electricity. This charge can kill or cause a serious shock or burns under certain conditions. Make sure that the power cords are in good working condition and that plugs are not broken. Keep cords away from oil and hot surfaces.
16. Never use electrical tools around flammable vapors or gases. This could cause an explosion.
17. Be sure that your hands are dry before using an electrical power tool.

18. Never use measuring tools on metal while it is being machined.
19. Always keep machine guards in place. They were put there for your protection.
20. Operate a machine only after you have had instruction on it. Remember that you must know what you are doing before you start a machine.
21. Stop a machine before oiling it.
22. Never "feel" the surface of a metal while it is being machined.
23. Clean chips off with a brush -- never with a rag or your hand.
24. Never allow anyone to stand near a machine that you are operating.
25. You can pinch your fingers with a pliers or snips. Be careful when using these tools.
26. Files are brittle. Handle them carefully. They can shatter in your hands. Always use a file with a handle.
27. Choose the right tool for the job.
28. Wear protective clothing when working with hot metals.
29. Wear a face mask when there is danger of flying chips.
30. Wear goggles when grinding metals.

PLASTICS

1. Wear proper eye protection.
2. Never inter-mix anything unless you understand the reactions of the mixture.
3. Use proper ventilation, as toxic vapors may be given off.
4. Never work around open flames.
5. Wear plastic gloves and other protective clothing that will help to guard against skin irritation.
6. Wear protective gloves for handling hot plastics.
7. Use a face mask and an appropriate respirator when sanding fiberglass or other plastic materials that produce hazardous dust.

8. Keep materials with low flash points under refrigeration.
9. Keep all guards in place when operating any plastics machine.
10. Warning signs and protective devices should be provided at each plastics heating unit.
11. Use only recommended materials and procedures for injection mold forming processes.
12. Properly dispose of all flammable waste material.
13. Certain catalytic reactions produce a great deal of heat. They should be mixed in metal containers only.
14. Always add catalyst to resin -- Never resin to catalyst.

SOLDERING

1. Wear adequate eye protection.
2. Before attempting to light a bench soldering furnace, make sure that the gas is turned off.
3. If the furnace does not have a pilot light:
 - a. Place a match or lighted piece of paper in the furnace;
 - b. Slowly turn on the gas until it ignites;
 - c. Adjust the flame so that all fire is contained within the furnace.
4. Work in a well-ventilated area.
5. Do not inhale fumes from soldering processes.
6. Use care in removing excess molten solder from the copper; consult your instructor for the proper procedure to use.
7. Clean up spilled flux immediately.
8. Wash hands after soldering. Flux can cause burns to the skin or damage clothing.
9. In case of acid burns, flush immediately with water.
10. Be aware of the rapid rate of heat transfer throughout thin metal.
11. Do not use electric guns or irons while standing or working in wet areas.

S

12. Care should be taken not to cut or burn the electrical cords on electric soldering guns or irons.
13. Clean up your area.
14. Do not leave hot metals where others can contact them.

WOOD

1. Always keep tools and equipment in top condition.
2. Wear eye protection when working in the shop.
3. Follow the safety procedures recommended for each power tool.
4. Wear tight fitting clothing.
5. Roll up your sleeves.
6. Remove loose clothing and jewelry.
7. When working with heavy pieces of wood such as sheets of plywood and two by four studs, wear a sturdy pair of shoes.
8. Keep materials neatly stacked.
9. Keep your work area clean and free from small scraps, excessive sawdust and oil.
10. Always remove nails from used lumber.
11. Keep tables of machines and other work surfaces free of nails, tools, wrenches, and materials.
12. Never try to move materials past a person who is using a power tool or machine.
13. Never attempt to speak to or otherwise startle a person using a power tool or machine.
14. Never start or stop a machine for someone else. Always follow the machine operator's instructions when helping.
15. Make sure that all hand tools are sharp and in good working order.
16. Always carry sharp or pointed tools away from your body. Never put them in your pockets.
17. Never hold a small piece of wood in your fingers as you cut it.

18. Always use the guards on machines when provided. If a standard guard cannot be used make use of holding and clamping devices and push sticks.
19. Plan your work before you begin. If large stock is to be cut, get help before you begin, not after you are in difficulty.
20. Never work on machines or power tools if you are tired or hurried. Accidents often happen when someone tries to do things too fast.
21. Make sure that a machine has come to a full stop before adjusting or oiling it, or changing a blade.
22. Always wear goggles or a face mask if there is a danger of flying chips.
23. Get first aid treatment for even the slightest scratch.
24. Wear a dust-respirator when sanding.
25. Wear ear protection such as ear plugs or ear muffs when excessive noise is a problem.
26. Know the location of the fire extinguisher with proper extinguishing agents for wood, flammable liquids and electrical equipment.

Class A fire - woods and paper products

Class B fire - flammable liquids

Class C fire - electrical equipment

27. Return all finishing materials to metal containers and cabinets.
28. Place all oily rags in a metal approved container.
29. Use the dust collection system for stationary tools if possible.
30. Keep your fingers and hands out of the path of sharp edged cutting tools.

Safety is one aspect of power technology that cannot be over emphasized. Electrical voltages, flammable liquids and gases, extremes of heat and cold, high pressure fluids, heavy equipment and controlled burning of fuels are some of the dangerous situations in a power technology laboratory.

GENERAL PRECAUTIONS

1. Lubricate or adjust moving parts only with teacher's permission. Use caution when working near any moving parts.
2. Whenever possible, work with all switches and controls in the "OFF" position. The person performing the work should have control of any switch that controls the device. This can be accomplished by the use of keyed switches by locking out the switching device, or by making it inoperative until the person conducting the work makes it operative (i.e., remove fuses, wires, power source, etc.)
3. Always consider an electrical circuit as "LIVE" until you personally confirm that it is not.
4. Always consider a device that produces heat as hot until you personally confirm that it is not. Do not touch it.
5. Do not pour flammable or explosive liquids into open containers or into an operating device.
6. Adjust moving parts of machinery or equipment only after it has been stopped and prevented from being unintentionally started during the adjustment.
7. Use extreme care when performing any heat producing operation (welding or soldering) near power technology equipment or machines that have oil or other flammable liquids near, in or on them.
8. Wait for a device to cool before making adjustments.
9. Make sure that access doors or hoods are secured in the open position before making any adjustment on a piece of equipment.
10. When starting a device, make sure all unauthorized personnel are clear of the device and that all tools, equipment, and flammable materials have been removed from the area.

- S
11. Adequate eye protection is required when working in a power technology area.
 12. Do not start a device or throw a switch just to see what will happen. Obtain instruction first.
 13. Turn off electrical power before replacing fuses. Be sure to locate the cause of a blown fuse or tripped circuit breaker before replacing fuses or resetting breaker.
 14. All experimental boards or equipment should be fused properly.
 15. Inspect all wiring and fluid circuits for defects before working on a device.
 16. Make sure all electrical devices are properly grounded.
 17. Make sure any electrical component is discharged before touching (capacitors and condensers).
 18. When working with an electrical test probe, keep one hand in your pocket or behind your back so that you will not touch a ground wire and complete the circuit.
 19. Metal jewelry, watches, rings, chains, etc., should not be worn when working on electrical equipment.
 20. Follow instructions when handling and charging storage batteries, and use appropriate personal protective equipment.
 21. Wear gloves and a face shield when handling cathode-ray tubes. **WARNING: CATHODE-RAY TUBES ARE AN EXTREME EXPLOSION HAZARD.** An instructor must be present when handling Cathode-Ray Tubes (CRT). CRT's are under high vacuum and if broken, an implosion will result causing glass to be thrown over a considerable area.
 22. Always use the proper tool for the job. Use wrenches not pliers for adjusting belts and nuts.
 23. Use care in soldering so as not to flip the solder. Do not leave any hot soldered part until it cools so that someone will not come along and touch it.

PERSONAL HEALTH CONSIDERATIONS

1. Wear an approved respirator while spray painting or abrading materials such as fiberglass and other toxic produce materials.

2. Do not clean hands in solvent or gasoline. These materials are explosive and may irritate the skin.
3. Lift heavy objects properly to avoid back strain.
4. Never place any part of your body in front of a high pressure grease gun or a high pressure air hose.
5. Keep all open wounds dressed and free of dirt.
6. Do not wear loose clothing or jewelry. Confine hair so that it will not be a hazard to you.
7. Never aim an air hose at another student.
8. Never use compressed air to blow dirt away from skin.
9. Do not jack up a vehicle if anyone is under it. Once the vehicle is jacked up, secure with permanent jack stands and do not shake vehicle or climb on it while it is elevated.
10. Make sure long jack handles are barricaded or raised out of the way to avoid someone tripping over them.
11. Do not use a bumper jack to raise a vehicle.
12. Do not run a vehicle when on a hoist. Use caution when lowering a vehicle.

DRIVING AND LOCATING A VEHICLE FOR WORK

1. Do not wear eye protection with restricted vision when driving a vehicle in the shop.
2. Vehicles should be driven only by students with valid driver's licenses and with the instructor's permission.
3. Work should not be performed on vehicles parked in heavily travelled areas or on public thoroughfares.
4. Towing or pushing should be done only with instructor approval.
5. Have a fellow student guide you when parking a vehicle in a congested area.
6. Someone must be in the driver's seat of a vehicle when the engine is being started.

GREASES, OILS, FUELS, AND SOLVENTS

1. Clean up all spills immediately and ventilate.

2. Use only approved solvents for cleaning parts. Do not use gasoline.
3. Be sure that there is proper ventilation before an engine is started.
4. Keep oil-soaked rags in approved oily waste containers, and dispose of them daily.
5. Check fuel connections for leaks before starting an engine.
6. Keep flammable liquids in closed approved containers.

STORAGE BATTERIES

The storage battery that you are most likely to come in contact with is the automotive storage batteries. Because of its compact size and the fact that it is so common, sometimes we tend to become careless in our use of the battery.

The following are some rules of caution:

1. Batteries should be stored or charged only in well ventilated areas. Do not breathe fumes of battery acid.
2. All sources of ignition should be remote from the battery storage area; i.e., no smoking, no lighted matches, no sparking from tools.
3. Do not work on batteries while on discharge or charge.
4. Proper protective clothing should be worn when handling batteries; i.e., rubber gloves, face shield, and apron.
5. Metal jewelry such as rings, bracelets or necklaces should not be worn around batteries.
6. Deluge showers and eye baths should be provided adjacent to the battery charging area.
7. Acid spills can be neutralized with a bicarbonate of soda solution, or diluted by large quantities of water applied immediately.
8. Battery chargers should be connected or disconnected only when charger is off and caps are in place.
9. When "jump starting" a battery, make the second connection of the jumper cable on the frame of the vehicle not on the battery terminal.

Some of the more serious potential hazards from batteries are:

1. Explosion due to improper connections.
2. Acid spills by incorrectly handling.
3. Back strain from improper lifting.

FLAMMABLE AND COMBUSTIBLE LIQUIDS

Flammable and combustible liquids are categorized by their ease of ignition. Flammable liquids are more easily ignited than combustible ones. Examples of flammables are gasoline, acetone, and lacquer thinner. Examples of combustibles are kerosene, fuel oil, mineral spirits, and brake fluid.

Flammable and combustible liquids are essential in many industrial arts classes. They must be stored and used in a manner that will provide a high degree of safety. Always read the label on the container before using any of these materials. Flammable and combustible liquids are potentially dangerous because:

1. Many produce vapors that are heavier than air and can accumulate along floors or other low points, lying in wait for a stray spark.
2. Many are readily oxidized, or release heat incurring so that rags or waste coated with them will catch fire spontaneously.
3. Vapors from some have harmful effects and can cause damage to nervous and/or waste elimination systems of the body.
4. All are poisonous if taken internally.
5. Most will remove protective oils from the skin, and repeated exposure can cause dermatitis (skin rash).
6. Nearly all will burn violently. Such fires are difficult to extinguish without proper extinguishing agents.
7. When burning, most flammable liquids will produce dense black smoke that may drive you from the room before the fire can be put out.

Store and Handle Flammable and Combustible Liquids Safely:

1. Be sure the exhaust fan or vents are operating in the flammable liquids store room.
2. Draw out only as much as you need for your class period or particular operation.

3. Dump waste or excess materials only in covered metal containers, as directed by the instructor. Care should be taken to avoid mixing liquids which may cause a chemical reaction.
4. Use a funnel when pouring into a small container.
5. Clean up spills and drips immediately, disposing of the rags and waste materials as instructed.
6. Read and follow instructions for handling and mixing catalysts with resins or finishes.
7. Never pour catalysts back into the bottle.
8. Always add catalyst to resin, not resin to catalyst.
9. Never apply resin, paint or other finishing material near areas used for cutting, welding, grinding or other hot work.
10. Be sure that the working area is well ventilated.
11. Store thinners and solvents only in original purchase containers or approved safety containers.
12. Use rubber gloves to minimize chances of skin irritation when working with epoxy and polyester resins.
13. Wash hands and other exposed skin areas before leaving the shop.
14. All flammable materials should be stored in closed containers when not in use.
15. Storage cabinets must be distinctly marked "FLAMMABLE-KEEP FIRE AWAY."

Some of the more hazardous flammable liquids that you may encounter in your shop activities are (listed in approximate order of hazard):

- ** Aerosol cans
 - Gasoline
- * Catalysts M.E.K. Peroxide
 - Carburetor cleaner
 - Acetone
 - Lacquer and lacquer thinner
 - Adhering liquid (for silk-screen process)

S

Paint thinner

Alcohol

Shellac

* Japan dryer

Kerosene

Paint

Resin (polyester)

Stain and varnish

Danish oil

*These materials could accelerate spontaneous combustion or could react violently when mixed with organic material.

**The hazard could vary greatly depending upon the propellant used in the can.

In the areas of visual communications, safety is not seen by some instructors and students as a major problem. It is because of this that it is necessary to outline some basic concerns related to visual communications.

DRAFTING ROOM

Although few hazards exist in the drafting room, there are some safety factors that the instructor must consider.

1. The paper cutter used in most drafting rooms could be responsible for serious cuts and pinches. In most cases, it is advisable to have it fastened in a permanent location and when not being used it should be locked in the closed position. A barrier type guard secured to the paper cutter should be no higher than 3/8" from the table, and located between the operator's hands and the blade. Do not remove guard.
2. Printers and developers, using ammonia, call for special safety instruction. Ammonia fumes in concentrated form are very toxic and should only be used in a well-ventilated area. Students should be advised not to inhale the fumes. If ammonia is spilled on the skin, it should be washed off immediately with soap and water.
3. Improper handling and use of compass, dividers, and hard lead pencils may result in painful skin punctures and eye injuries which can lead to infection or blood poisoning.
4. When sitting on a chair or stool be sure to keep all four legs on the floor. A major problem in the drafting room is injury resulting from falls from tilted chairs or stools.
5. Use care in adjusting the adjustable table tops.

GRAPHIC ARTS

Many of the equipment items and materials used in the graphic arts program are heavy, sharp, brittle, or awkward to handle. Size up the task before you attempt it and get help if needed. Recognize the inherent delicate nature of much of the equipment and do not abuse it.

Dark Room:

1. Turn on ventilator fan when in the dark room.
2. Chemicals should not be stored in glass bottles or on high shelves where they may fall and cause injury.

3. Chemical goggles and apron should be worn when preparing chemical solutions. Always add acid to water - never the opposite.
4. Tongs or rubber gloves should be used in handling film in the developing process.
5. Students who have skin allergies must wear rubber gloves while handling film or mixing chemicals.
6. Keep hands away from face while working in the dark room.
7. Wash hands carefully after developing film.
8. Portable electrical devices should not be used around or within reaching distance of sinks.
9. There shall be no unsafe conduct in the dark room.
10. All spills should be wiped up immediately.
11. Avoid chemical spills on clothing. Such spills may cause skin irritation.

Dry Mount:

1. Use caution to avoid burning yourself on the press or tacking iron.
2. Dry mount with heat setting prescribed by the instructor only.
3. Turn off and unplug press and tacking iron at end of the process.
4. Do not lay hot tacking iron down on papers or on the counter but return it to holder.
5. Report worn electrical cords and plugs to instructor.
6. Never test heat of press or tacking iron by touching.

Process Camera:

1. Do not touch hot lights.
2. Avoid flashing lights in students' eyes.
3. Caution should be exercised around glass copy board.

Stripping Tables

1. All foreign material should be kept off the glass so it will not be broken.
2. Keep fingers out of cutting area when cutting a flat.
3. The cutting devices should be stored properly and kept sharp.

Folding Machine:

1. Never attempt to remove a misfed or jammed sheet while the machine is running.
2. Turn off the power when making changes.
3. Keep all tools off the tables of the folder.
4. Be sure electrical cord is out of the way.

Plate Maker:

1. Disconnect the plate maker before changing carbons or making adjustments. Be careful of hot carbons when changing.
2. Never look at arc lights during operation.
3. Be careful not to break glass of vacuum frame.

Paper Drill:

1. Be aware that drill bit may be hot.
2. Keep hands away from drill area while drilling.
3. Keep area around feet clear at all times.

Air Brush:

1. Have instructor connect and disconnect regulators to high pressure air line.
2. Do not adjust regulators.
3. Take care not to spray toward other students' faces.

Sign Press:

1. Do not throw or toss type.

S

2. Utilize caution in keeping hands out of roller.
3. Use only specified cleaning solutions in cleaning type and press.
4. Do not lift or carry press during cleanup.

Engraving:

1. Goggles must be worn when engraving.
2. Keep hands from under cutter bit.
3. The instructor will change or adjust engraving cutters.

Thermography:

1. Dark goggles must be worn by all students in the area when heating the relief powder.
2. Students in the area are not to stare at the heat lamp.
3. Do not leave area when the lamp is on and relief powder is heating; fire may result.

Rubber Stamp and Gold Stamping:

1. Exercise caution when using heating element.
2. Keep work surface clean at all times.
3. Do not throw or drop type.

INSTRUCTIONAL TECHNIQUES

1. Reinforce safety consciousness in students through teacher example - always doing things the safe way while pointing out the potential hazard.
2. Teach accident prevention with a positive approach -- stressing the right way to perform an operation.
3. Present laboratory demonstrations emphasizing the safe use of potentially hazardous machines and hand tools. Document instructions and attendance.
4. Present safety instruction with the following objectives in mind:
 - A. Develop in students a sense of responsibility for their own safety and that of others.
 - B. Emphasize importance of hair protection and clothing to safety.
 - C. Help student understand that the safe way of doing things is effective.
 - D. Help students recognize situations involving potential hazards.
 - E. Help students learn safe practices to use in their own day-to-day activities.
5. Provide instruction on what to do in case of a shop accident
6. Present periodic demonstrations on the proper use and care of personal protective devices.
7. Use information sheets dealing with the general safety rules of the industrial arts laboratory.
8. Provide instruction in the basic maintenance of shop tools, machines and other equipment.
9. Provide instruction in the safe methods of lifting and/or moving heavy equipment or other loads.
10. Provide a bulletin board for safety bulletins, safety posters, and safety rules and regulations.
11. Require all beginning students to make a careful study of potential hazards in the laboratory during the first few days of the course.
12. Utilize a student safety committee to strengthen the safety program.

13. Use a bell, whistle, or some other type of alarm to command the attention of every student in the laboratory during emergency situations.
14. Test students on the safety information with which they were provided.

SAFETY INSPECTIONS

1. Use a safety check-list to assure that all safety factors are checked during safety inspections.
2. Have in-depth safety inspections of the industrial arts facility made at least annually.
 - a. School personnel - state and/or local level.
 - b. A student safety committee.
 - c. A student inspector or foreman.
3. Encourage teachers to welcome inspections by:
 - a. Insurance safety engineers;
 - b. Inspectors from the State Department of Labor and Industry;
 - c. State fire inspectors;
 - d. District Safety Coordinator.
4. Rotate assignments of students to the safety committee.

SAFETY INSTRUCTIONS FOR ALL AREAS OF INDUSTRIAL ARTS

1. Instructor approval must be obtained for work on all machines or in potentially hazardous areas.
2. Report all injuries, however slight, to your instructor immediately.
3. Wear eye protection as required by law.
4. If your hairstyle presents a potential hazard, you must fasten it securely or wear a protective hair cover.
5. Suitable clothing and shoes must be worn for all laboratory activities. Remove or fasten any loose clothing, neckties or jewelry. Roll loose sleeves to elbows.
6. Obey rules concerning operators' safety zones.
7. Cooperate with your classmates in the management of your industrial arts safety program.
8. Caution any student committing an unsafe act.
9. Report to instructor any equipment that does not seem to work properly.
10. Keep tools and materials from projecting over the edge of benches.
11. Use a brush to clear away dry chips. Use a rag to clean oily areas.
12. Keep floor and work surfaces clear of scraps and litter.
13. Wipe up immediately any liquids spilled on the floor.
14. Be sure projecting drawers and doors are kept closed.
15. Place oily rags and other combustible materials in approved metal containers, and empty daily.
16. Use care in handling and storing large, heavy or long pieces of material.
17. Wear a respirator if the operation generates dust or fumes.
18. Wear ear protection when excessive noise is encountered.

SAFE PRACTICES IN THE CARE AND OPERATION OF EQUIPMENT

1. Enclose all gears, moving belts, and other power transmission devices or erect barricades to prevent contact.
2. Permit each student to operate a machine only after demonstrating an ability to operate the machine safely.
3. Require a signed statement from a parent granting permission for students to operate power machines.
4. Prohibit students from operating machines and using hand tools when the instructor is not present.
5. Prohibit the use of defective tools, machines, or other equipment.
6. Maintain strict supervision of students who are using machines and tools.
7. Prohibit the removal of guards and safety devices.
8. Maintain the awareness of the effective use of safeguards against the potential hazards associated with industrial arts activities.
9. Provide safety zones around each piece of equipment by designating the area with painted lines.
10. Prohibit conversations between machine operators and other students while using machine.
11. Secure all machinery and equipment in place.
12. Post safety rules at or near each potentially hazardous machine.
13. Identify the industrial arts laboratory as an "Eye Protection Area" with appropriate signs.

SAFETY RULES FOR POWER EQUIPMENT

1. Do not operate any machine until you have received proper instruction, fully understand how to operate it, and have received the instructor's permission to use it.
2. Wear proper eye protection devices at all times in the laboratory.
3. Have your instructor check your work setup.
4. Check and make all adjustments before turning on the power.
5. Make sure other persons are clear before turning on the power.
6. Guards must be in place and function properly.
7. Start and stop your own machine and remain with it until it has come to a complete stop.
8. Only one person should operate a machine unless the operation requires a helper.
9. Do not leave a running machine unattended.
10. Disconnect electrical power before oiling and cleaning.
11. Allow a safe distance between your hands and blades, cutters or moving parts. Keep fingers in such a position that there is no danger of their slipping into the cutter or moving parts.
12. Keep machines clear of tools, stock, and other items.
13. Keep the floor around machines clear of liquids, scraps, tools, and material.
14. Give the machine your undivided attention while you are using it. Do not look away to talk to others.
15. Never lean or lounge on any machine.
16. Do not use extension cords for permanent connections.
17. Notify your instructor of any breakage or malfunction.
18. Allow all machines to come to a complete stop before removing work or making a new setup.

USE OF EQUIPMENT INSTRUCTION SHEETS

The equipment instruction sheets that follow are designed to be used as an information sheet and a follow-up quiz. These sheets contain only basic information and safety rules. They should not be considered to be a complete safety instruction package.

Different manufacturers' equipment may require changes in the sheets. Additional material should be developed to fit individual needs and to supplement the information provided.

For Safety —

1. Operate only with instructor's permission and after you have received instruction.
2. Remove jewelry, eliminate loose clothing, and confine long hair.
3. Make sure all guards are in place and operating correctly.
4. Always use proper eye protection.
5. A welding helmet must be worn when welding.
6. Proper ventilation must be available.
7. Goggles must be worn when chipping slag.
8. Others in the area must be warned prior to striking an arc.
9. Gloves and proper clothing must be worn when welding.
10. Closed containers should not be welded without the instructor's permission.
11. Cables, clamps and electrode holder should be checked and working properly.
12. Screens to protect others must be in place before welding is started.

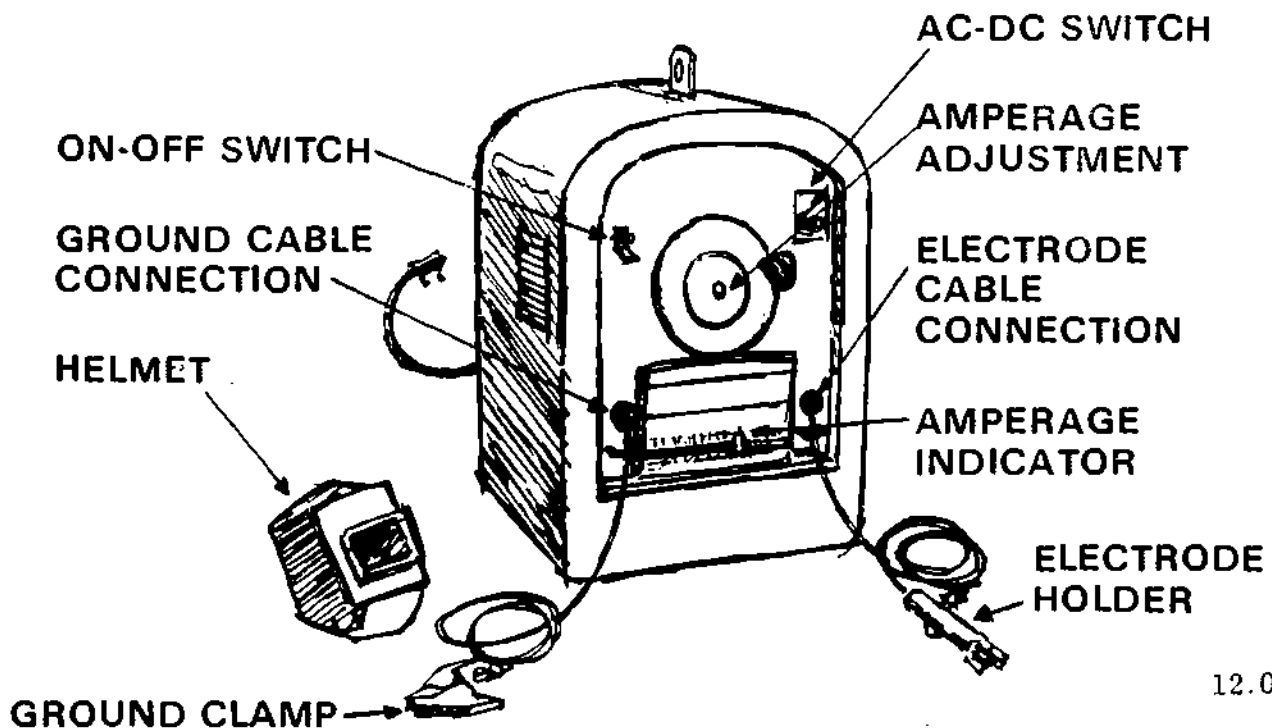

12.06

S _____

Name _____

Class _____

Date _____ Grade _____

Safety Quiz

(Circle True or False)

- | | | |
|--|---|---|
| 1. You should warn anyone nearby before you start to weld. | T | F |
| 2. Goggles as well as a welding hood should be available before you start to weld. | T | F |
| 3. A closed container is dangerous to weld. | T | F |
| 4. Gloves are not necessary when welding. | T | F |
| 5. It is dangerous to weld without proper ventilation. | T | F |
| 6. An electric shock is possible if both the electrode and ground are contacted. | T | F |

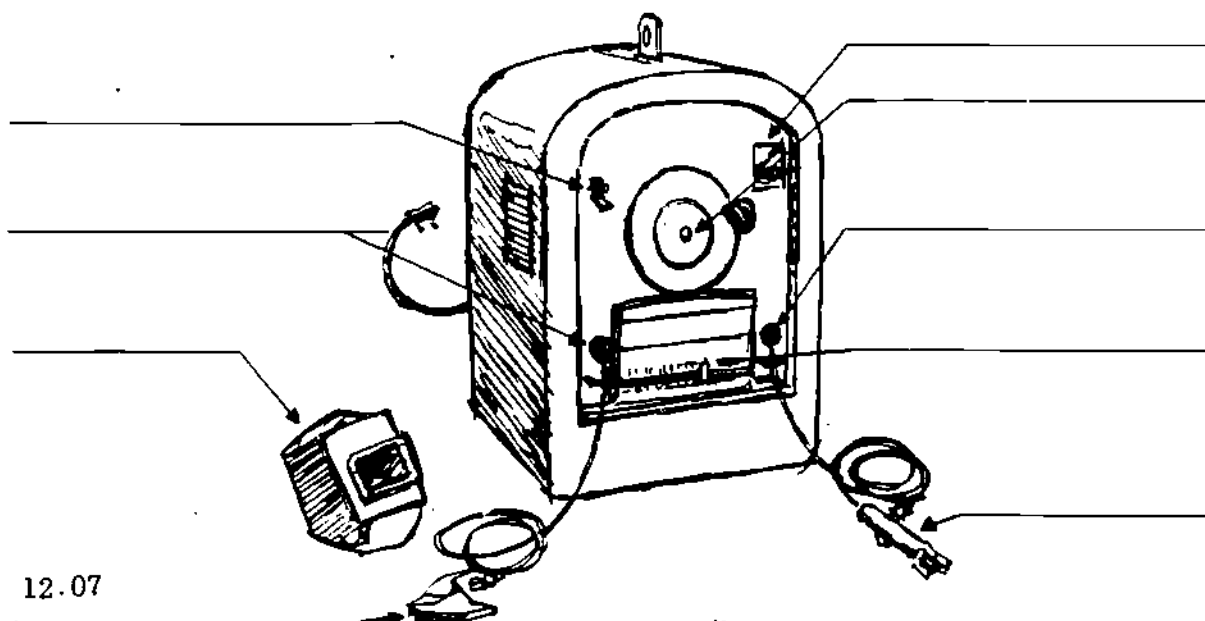

12.07

For Safety —

1. Operate only with instructors permission and after you have received instruction.
2. Remove jewelry, eliminate loose clothing, and confine long hair.
3. Make sure all guards are in place and operating correctly.
4. Always use proper eye protection.
5. Make sure all adjustments are tight and secure and blade guides are properly adjusted.
6. Upper blade guides should be positioned about 1/8" above the work piece.
7. Guide the work slowly, letting the machine do the work. Do not force the work into the blade.
8. Do not attempt to cut a smaller radius than the blade will allow.
9. Avoid backing out of a cut.
10. Place hands or fingers on each side of the cut line, never on the line. Use a scrap push block if necessary.
11. Never leave the machine until it has come to a full stop.

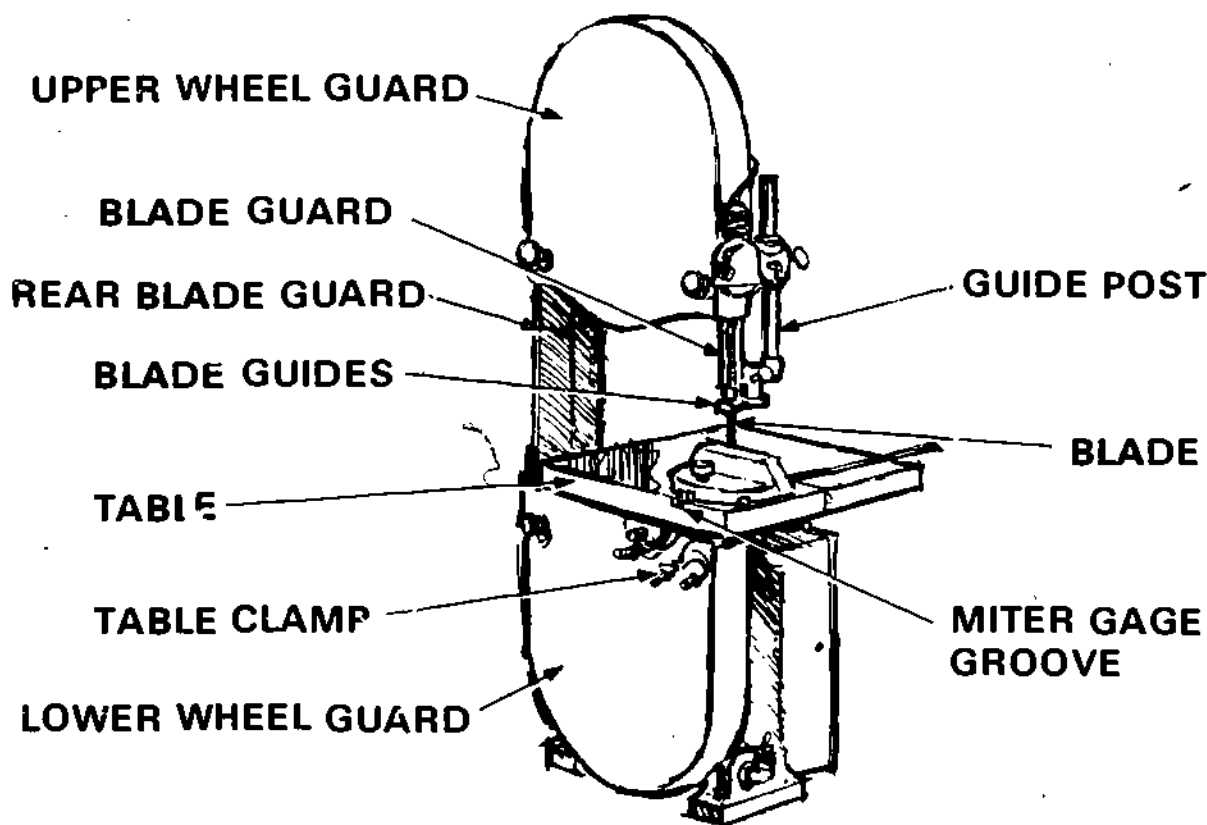

12.08

Band Saw

Name _____

Class _____

Date _____ Grade _____

Safety Quiz

(Circle True or False)

1. The lower wheel does not require a guard. T F
2. The upper guide should be adjusted to within 1/8" of the work piece. T F
3. All normal adjustments should be made with the power turned off. T F
4. It is permissible and safe to force the material around a tight radius. T F
5. Fingers should be placed on each side of the cut line and the material guided through the machine. T F
6. When necessary it is possible to back slowly out of a cut. T F

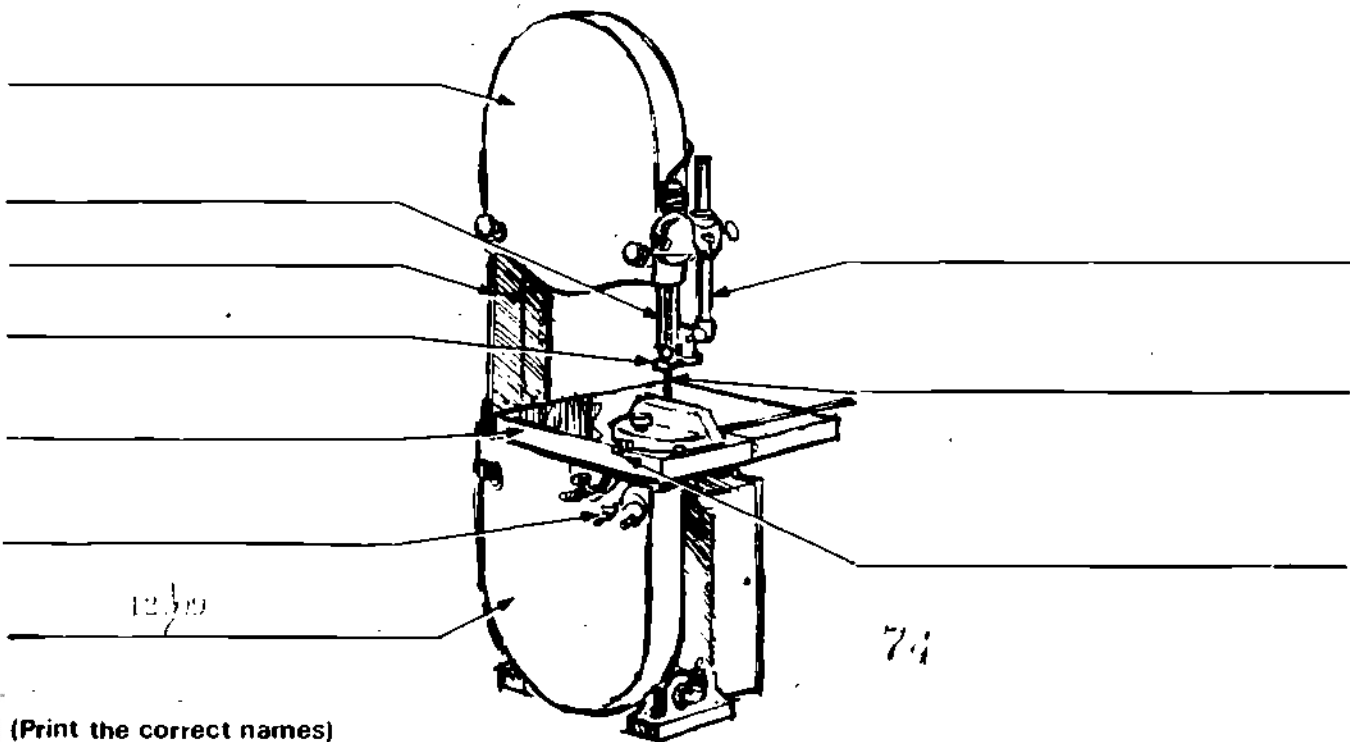

For Safety —

1. Operate only with instructors permission and after you have received instruction.
2. Remove jewelry, eliminate loose clothing, and confine long hair.
3. Make sure all guards are in place and operating correctly.
4. Always use proper eye protection.
5. Make all adjustments except final belt tracking with the power off.
6. Make sure there is adequate strong tension on the belt and that it is not torn.
7. When changing belts make sure the new belt runs as arrows indicate.
8. The table should be adjusted to within 1/16" of the abrasive belt.
9. Keep hands clear of the abrasive belt while operating and keep material flat on the table.
10. The belt must be re-tracked if the angle of the basic machine is changed.

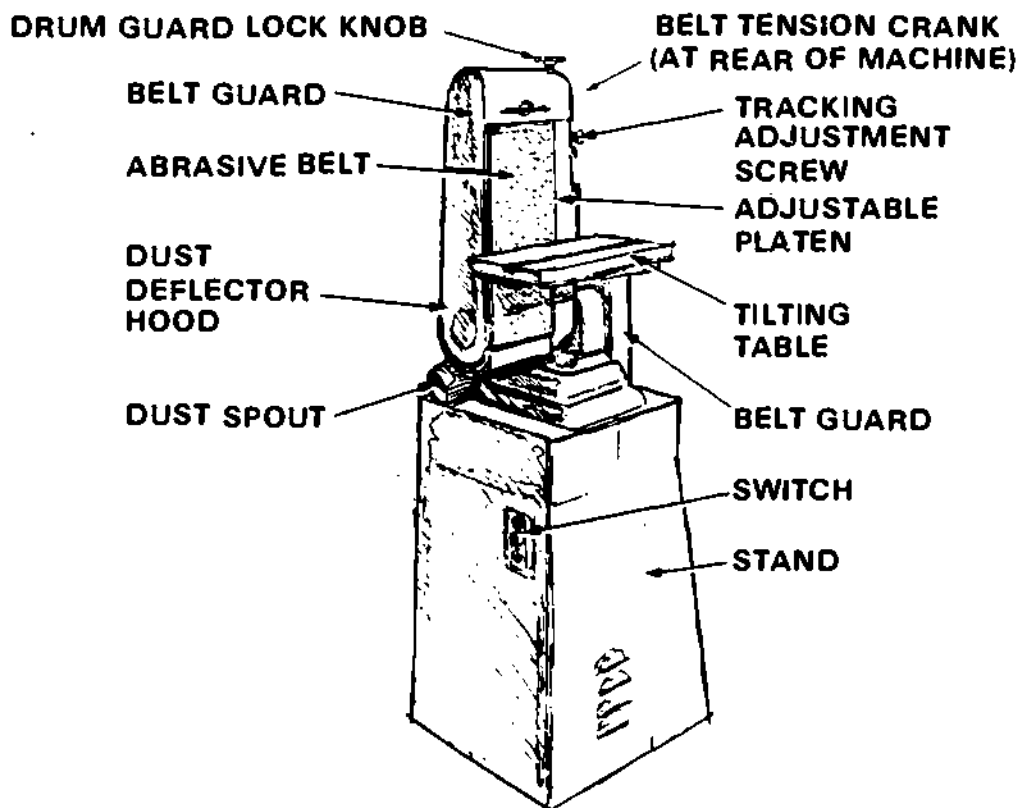

12.10

Belt Finishing Machine

S _____

Name _____

Class _____

Date _____ Grade _____

Safety Quiz

(Circle True or False)

1. Material may be safely sanded in the center of the platen. T F
2. The table should be $\frac{1}{4}$ " away from the belt for adequate clearance. T F
3. If the angle of the unit is changed belt tracking should be checked. T F
4. There are directional arrows inside the belt. T F
5. The guards cannot be removed from this machine. T F

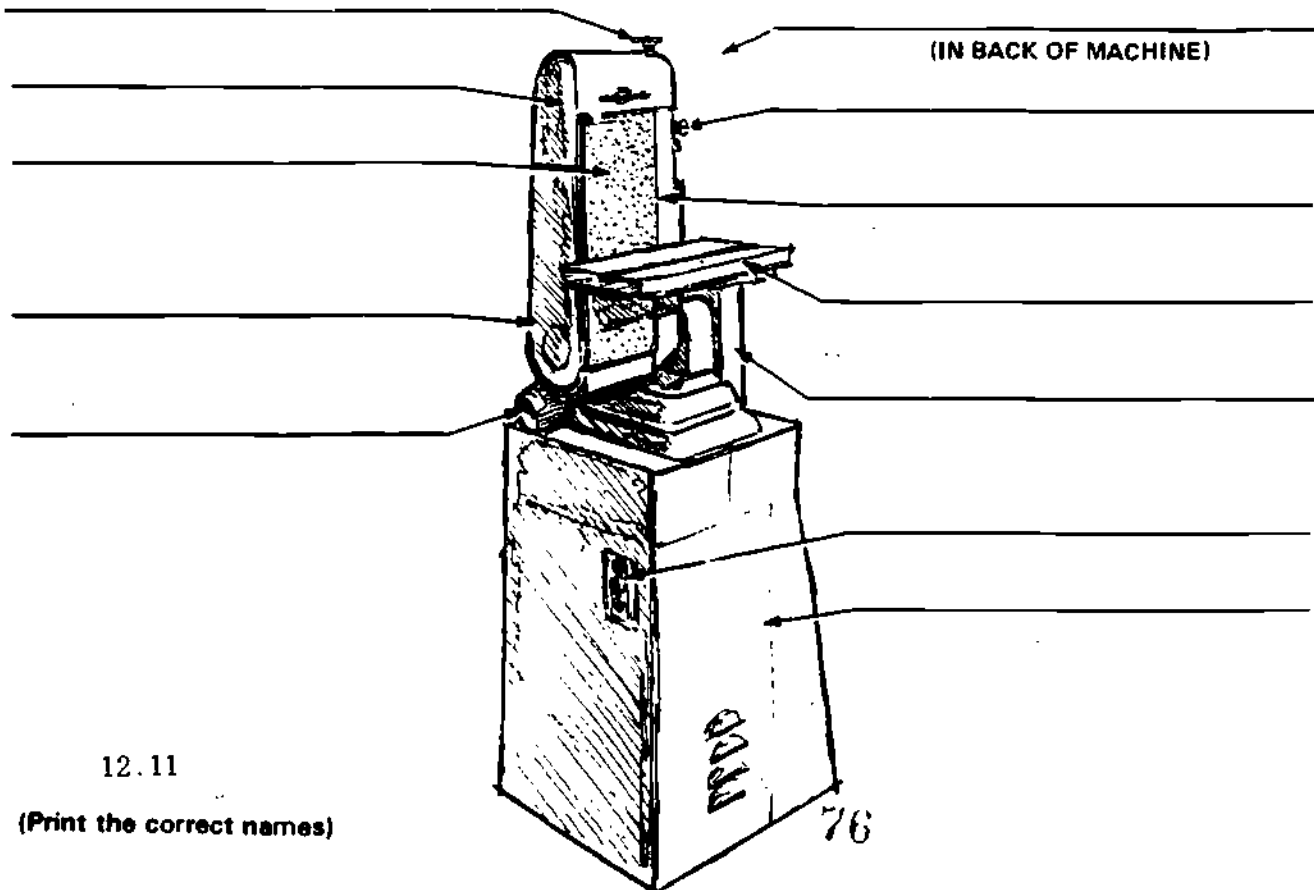

12.11

(Print the correct names)

For Safety —

1. Operate only with instructors permission and after you have received instruction.
2. Remove jewelry, eliminate loose clothing, and confine long hair.
3. Make sure all guards are in place and operating correctly.
4. Always use proper eye protection.
5. Always buff using the lower half of the buffing wheel.
6. Stand to one side of the wheel when buffing or applying compound.
7. Use care when buffing around corners or openings where the wheel could grab and throw the work piece.
8. Never use gloves, rags or part of a shop coat to hold the work piece.
9. Never buff a leading edge.

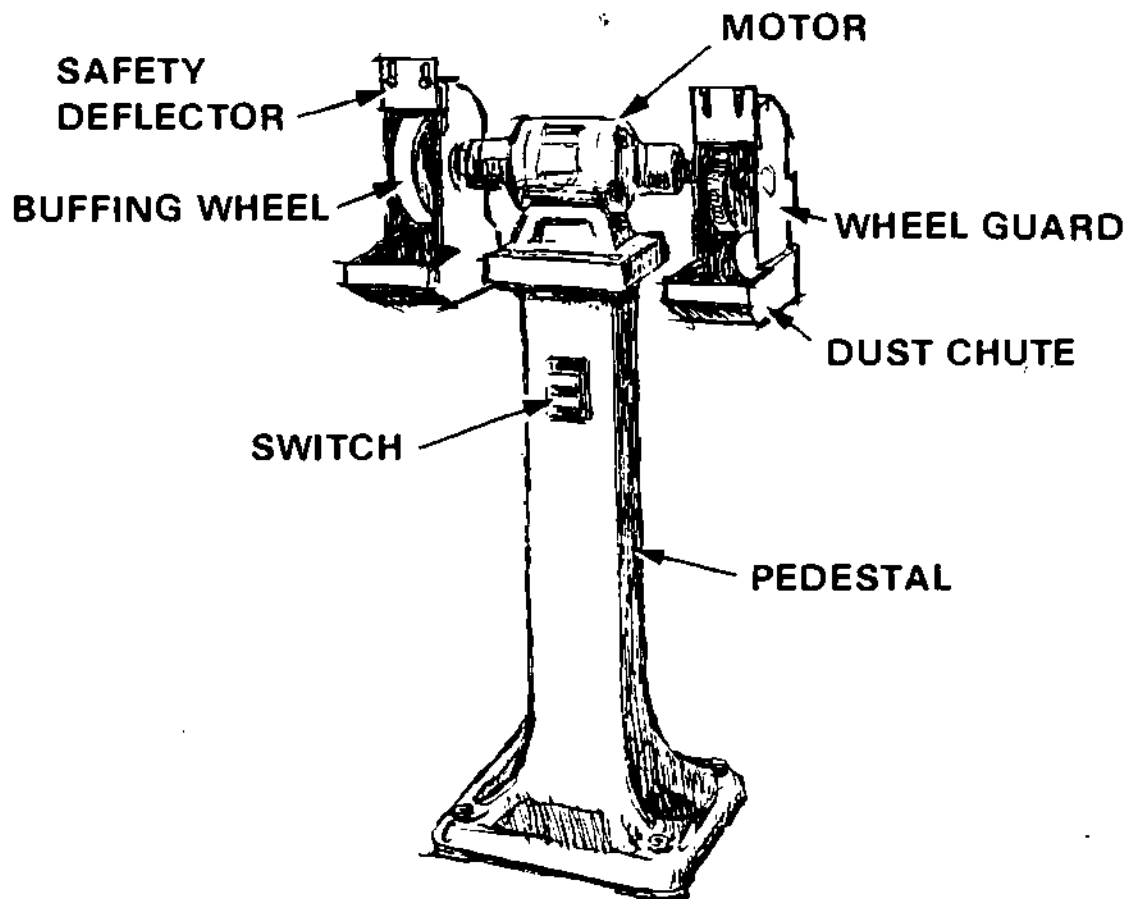

12.12

s _____

Name _____

Class _____

Date _____ Grade _____

Safety Quiz

(Circle True or False)

1. A rag should be used to hold hot objects while buffing. T F
2. Always buff on the lower half of the wheel. T F
3. Loose clothing or hair must be confined. T F
4. Eye protection must be worn when buffing. T F
5. Use extra caution when buffing corners or confined areas of the work. T F

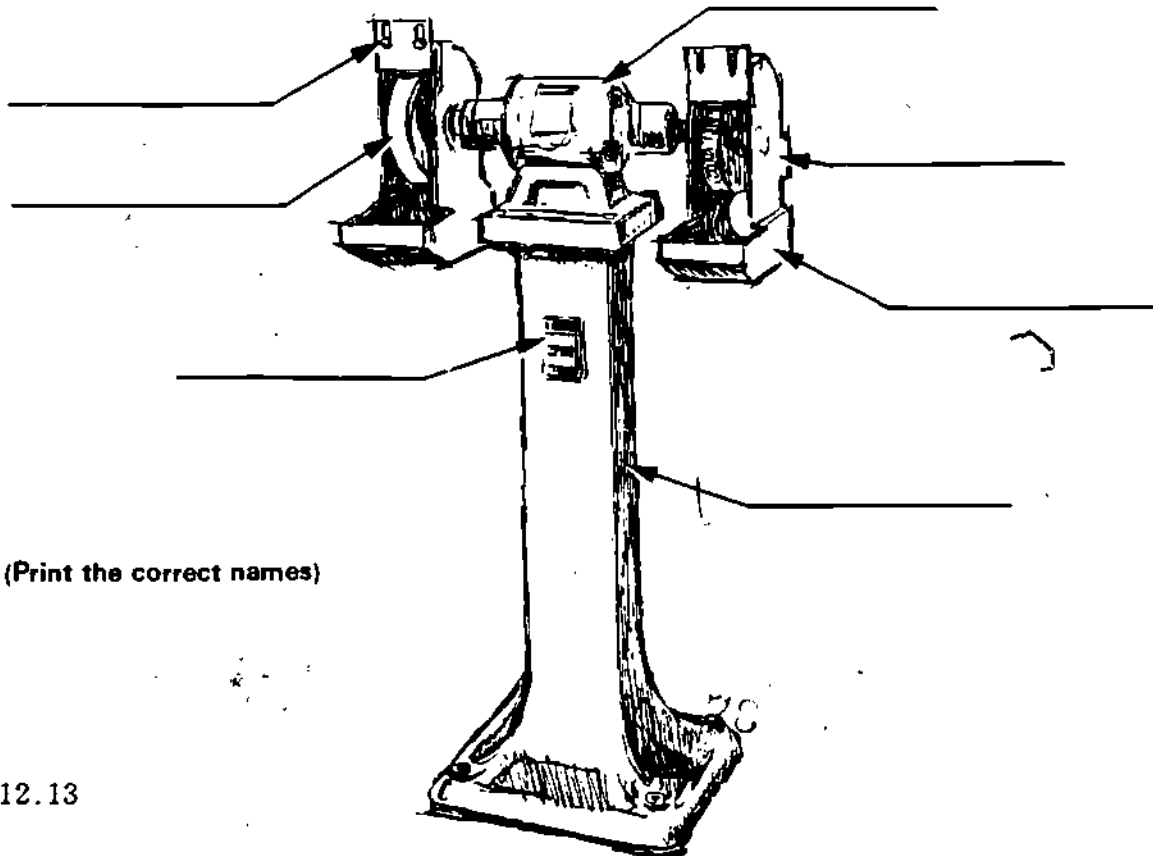

S _____

Name _____

Class _____

Date _____ Grade _____

Safety Quiz

(Circle True or False)

1. It is safe to saw freehand. T F
2. The fence should always be used. T F
3. The guard is not always necessary. T F
4. When ripping it is best to stand directly behind the blade. T F
5. Eye protection should be worn when using a table saw. T F
6. The saw blade should be adjusted so that the teeth clear the thickness of material to the depth of the gullets. T F
7. A helper or roller should be used when ripping long pieces. T F
8. A push stick is necessary when ripping narrow stock. T F

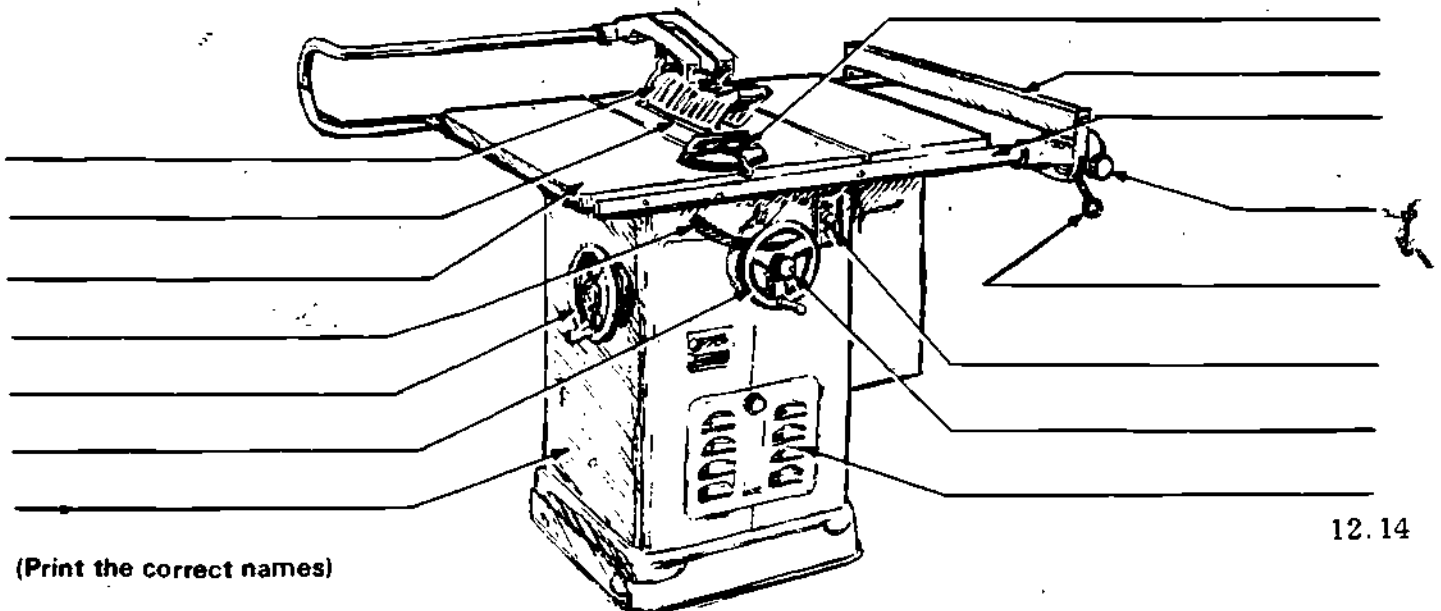

For Safety —

1. Operate only with instructors permission and after you have received instruction.
2. Remove jewelry, eliminate loose clothing, and confine long hair.
3. Make sure all guards are in place and operating correctly.
4. Always use proper eye protection.
5. Make all adjustments and remove chips or dust with the power off.
6. Never use the miter gage and fence together in the same operation.
7. The saw blade should extend above the work piece until the gullets of the blade clear the material.
8. Never saw free hand. Use the miter gage when cross cutting, the fence when ripping.
9. Never reach over the saw blade.
10. Use extra care and precaution when sawing large material, or when using a dado or molding cutter head.
11. Use a push stick when ripping narrow stock or when hands would be close to blade.
12. Do not stand in line of the cut when operating the saw.
13. Lower the blade and be sure it has come to a full stop before leaving the machine.

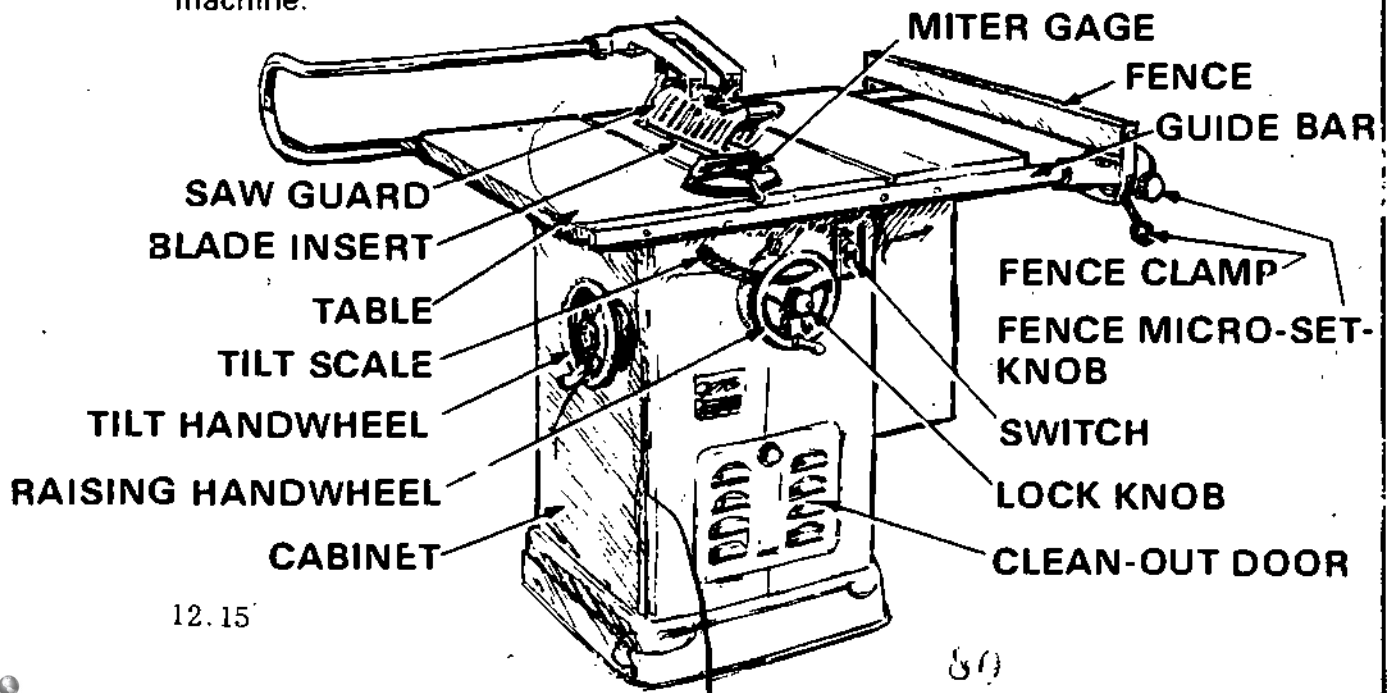

12.15

80

For Safety —

1. Operate only with instructors permission and after you have received instruction.
2. Remove jewelry, eliminate loose clothing, and confine long hair.
3. Make sure all guards are in place and operating correctly.
4. Always use proper eye protection.
5. Protective clothing must be worn-coat-gloves-face shield-shoes-leg protectors.
6. Do not throw metal in crucible, use tongs.
7. When pouring keep metal close to the floor and move slowly.
8. Do not step on metal spilled on the floor.
9. Be sure to pin crucible in pouring cradle.

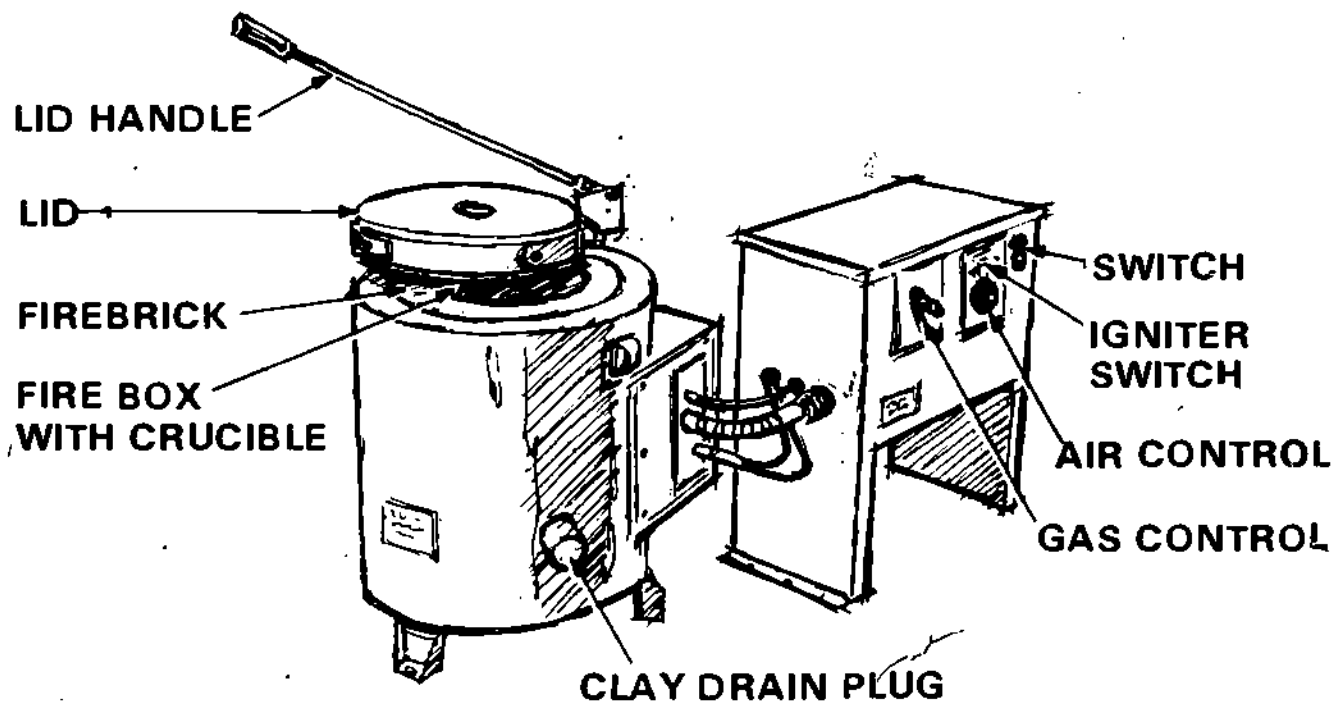

S _____

Name _____

Class _____

Date _____ Grade _____

Safety Quiz

(Circle True or False)

1. Metal accidentally spilled on the floor should be kicked aside. T F
2. When pouring you should move as quickly as possible. T F
3. Protective clothing is necessary when charging the crucible. T F
4. Metal should not be thrown or dropped into crucible. Tongs should always be used. T F
5. If goggles are used a face shield is not necessary. T F

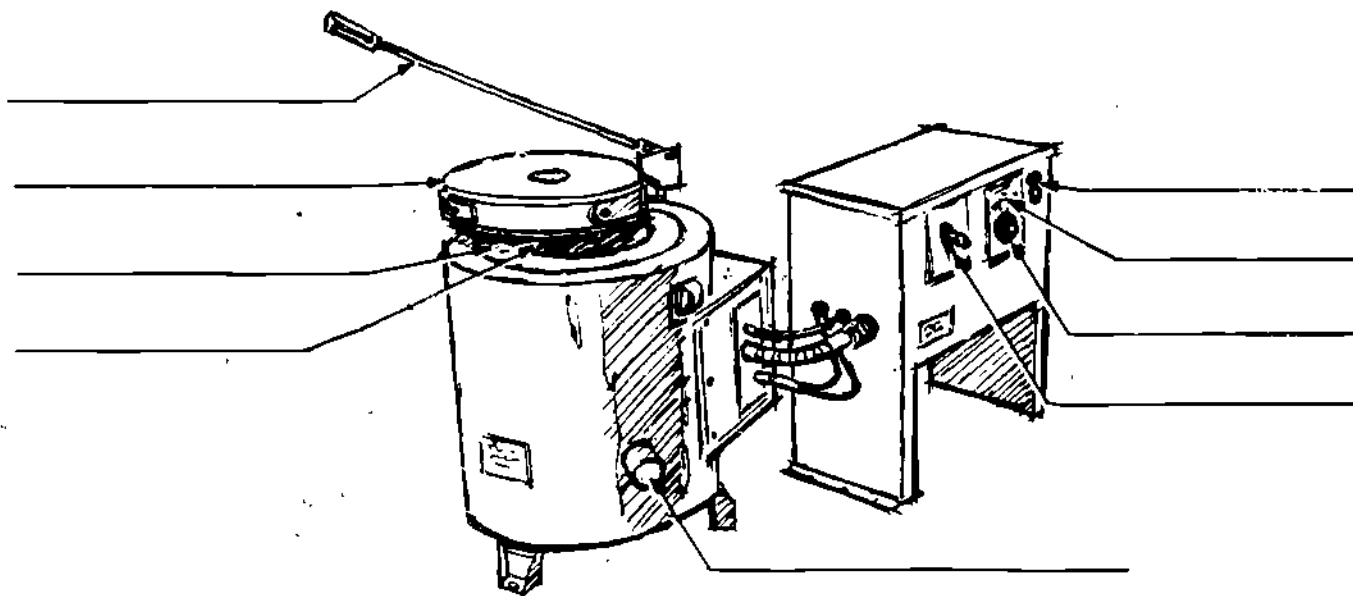

(Print the correct names)

12.17

82

For Safety —

1. Operate only with instructor's permission and after you have received instruction.
2. Remove jewelry, eliminate loose clothing, and confine long hair.
3. Make sure all guards are in place and operating correctly.
4. Always use proper eye protection.
5. Make sure adhesive is holding abrasive disc tightly to the revolving platen.
6. Abrasive disc should not be torn or damaged.
7. Material should be held flat against the table and hands kept clear of the abrasive disc.
8. The table should be adjusted to within 1/16" of the disc.
9. Work must be done on the side of the disc rotating downward.
10. Do not leave this machine until it has coasted to a full stop or been stopped with a piece of scrap wood.

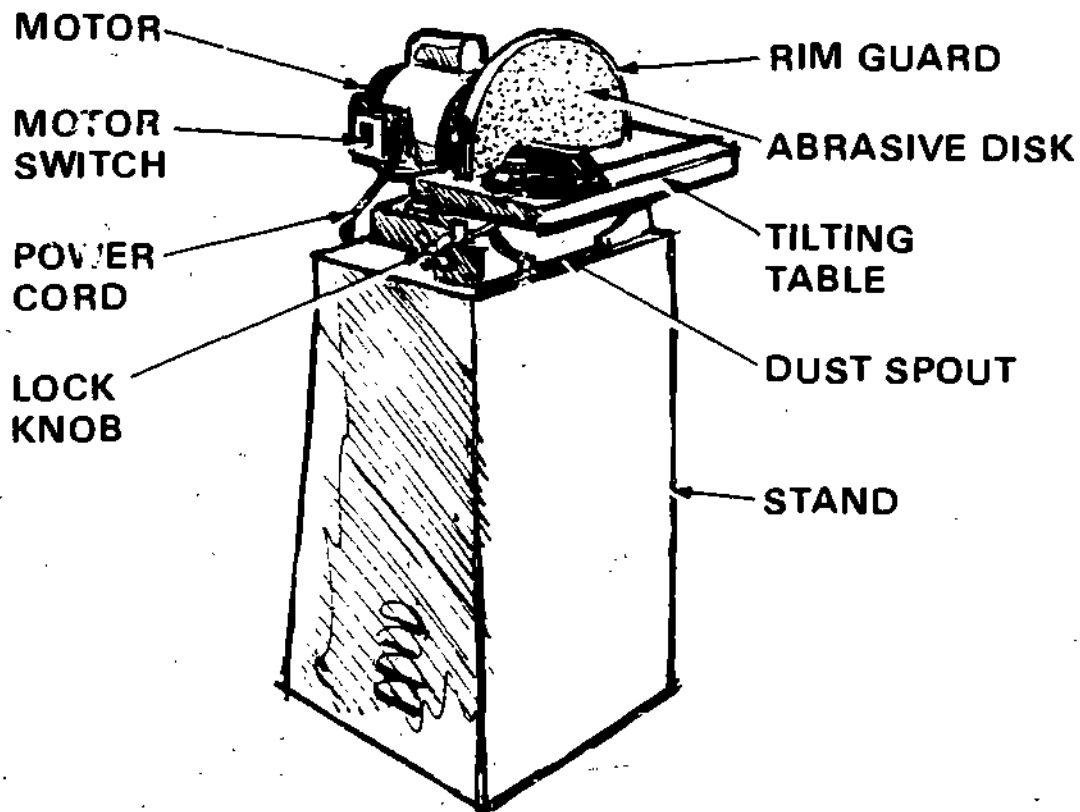

Disc Finishing Machine

S _____

Name _____

Class _____

Date _____ Grade _____

Safety Quiz

(Circle True or False)

1. Sanding can be safely done on either the left or right side of the rotating disc. T F
2. The Rim Guard is of no real value and can be removed for most operations. T F
3. The table should be adjusted to within 1/16" of the disc. T F
4. A piece of scrap lumber can be used to slow down and stop the disc after turning off the power. T F
5. The table may be tilted safely while the machine is running. T F

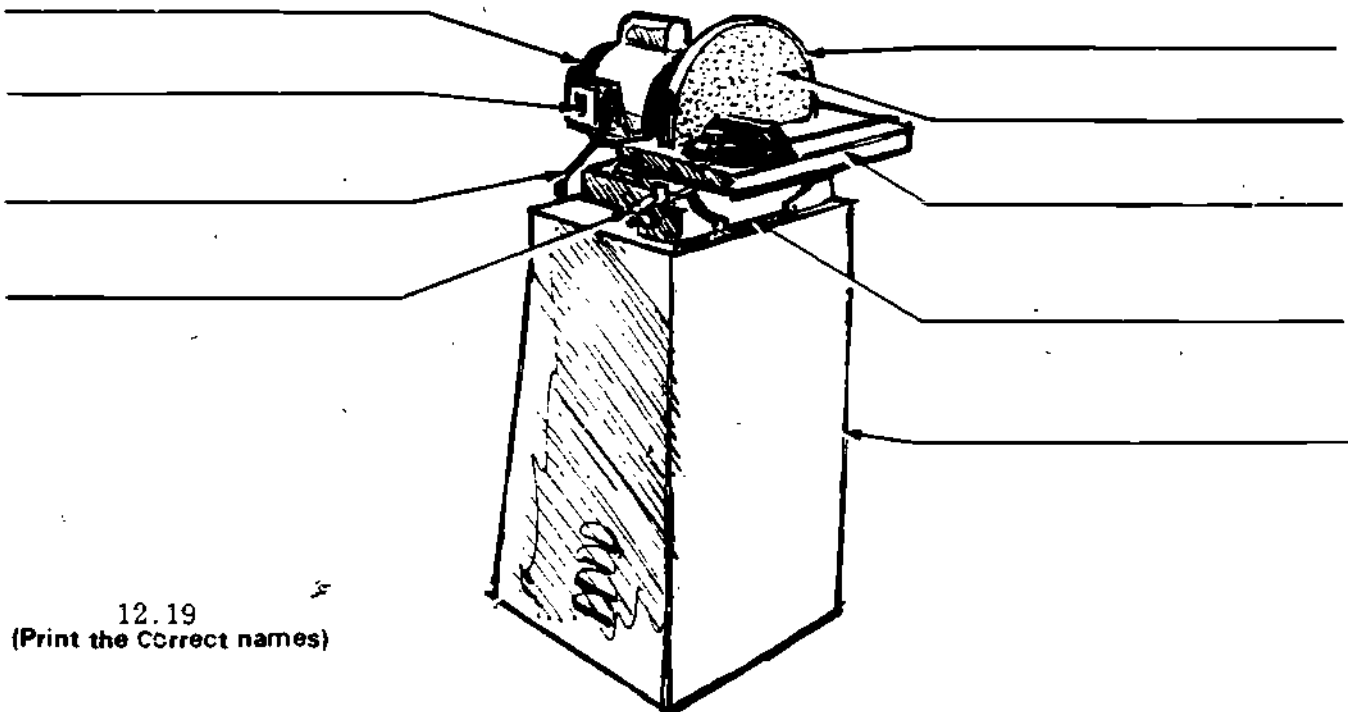

12.19
(Print the Correct names)

For Safety —

1. Operate only with instructors permission and after you have received instruction.
2. Remove jewelry, eliminate loose clothing, and confine long hair.
3. Make sure all guards are in place and operating correctly.
4. Always use proper eye protection.
5. Hold material securely with vise or clamps.
6. Be sure key is removed from chuck.
7. Select a properly sharpened bit. For metal, center punch when hole is to be drilled.
8. Turn off power if work piece is caught in the drill. Do not stop by hand.
9. Adjust table or depth stop to avoid drilling into the table.
10. Select the correct speed, normally slower for metal-faster for wood. The larger the bit, the slower the speed.

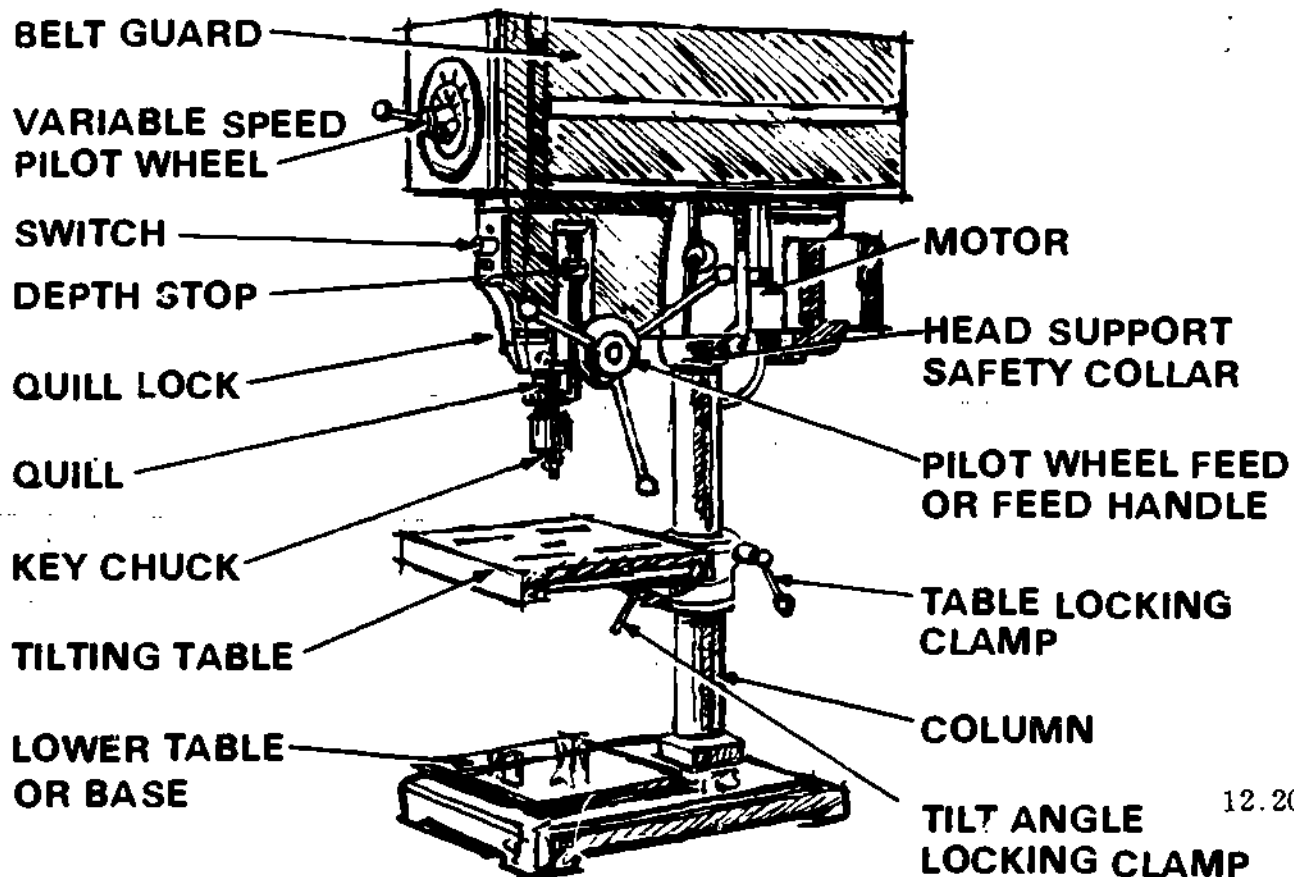

S _____

Name _____

Class _____

Date _____ Grade _____

Safety Quiz

(Circle True or False)

1. It is necessary to select the proper speed. T F
2. The chuck key should be kept in the chuck at all times. T F
3. Work should always be secured. T F
4. Rings may be worn while operating a drill press. T F
5. A chip brush should be used for removing chips. T F
6. The drill should be operated at top speed for all work. T F
7. The long end of the work should be to the left of the operator. T F

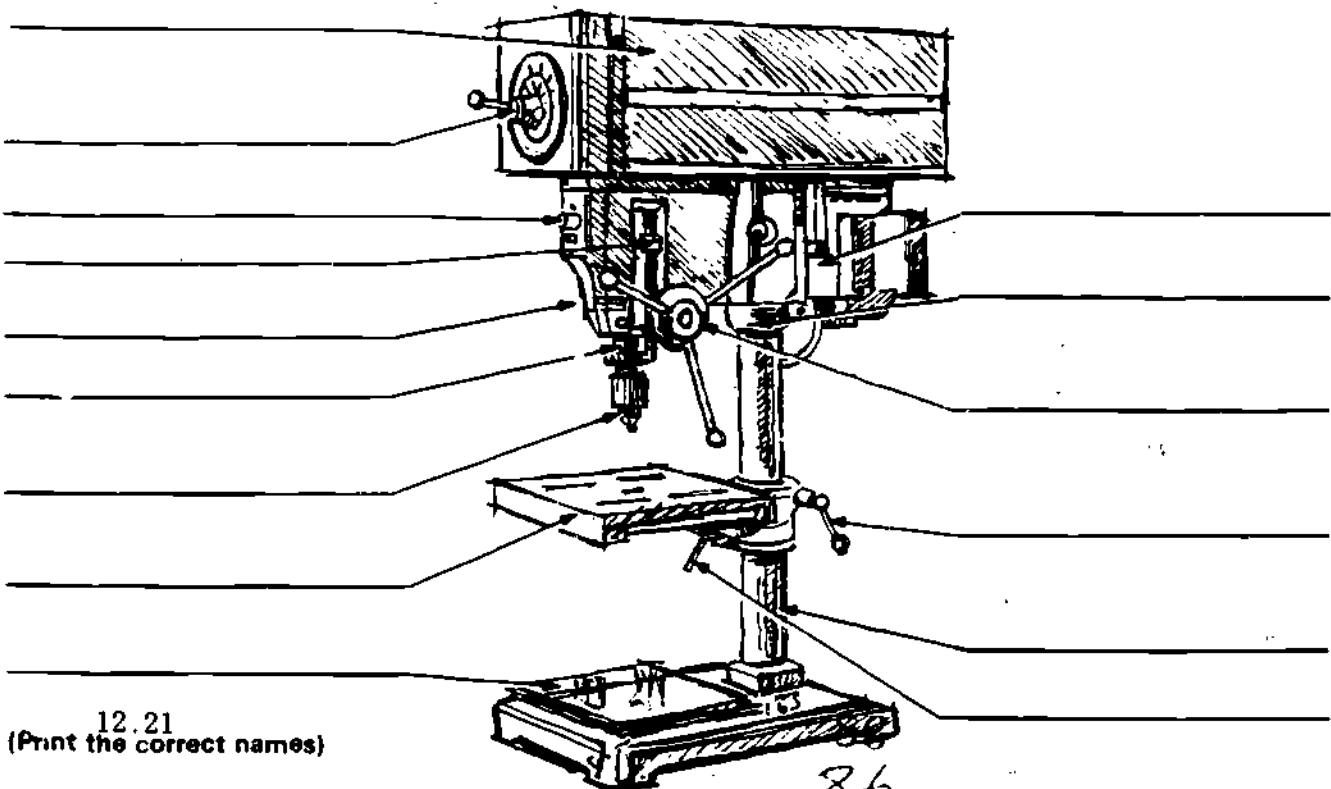

12.21
(Print the correct names)

For Safety —

1. Operate only with instructors permission and after you have received instruction.
2. Remove jewelry, eliminate loose clothing, and confine long hair.
3. Make sure all guards are in place and operating correctly.
4. Always use proper eye protection.
5. Observe the tool voltage (300 volts) and keep clear of all charged areas
6. Be sure to discharge the tool at the end of a cut.
7. If you spill oil, clean it up.
8. Do not activate the power supply until the dielectric oil tank is full and oil covers the workpiece.

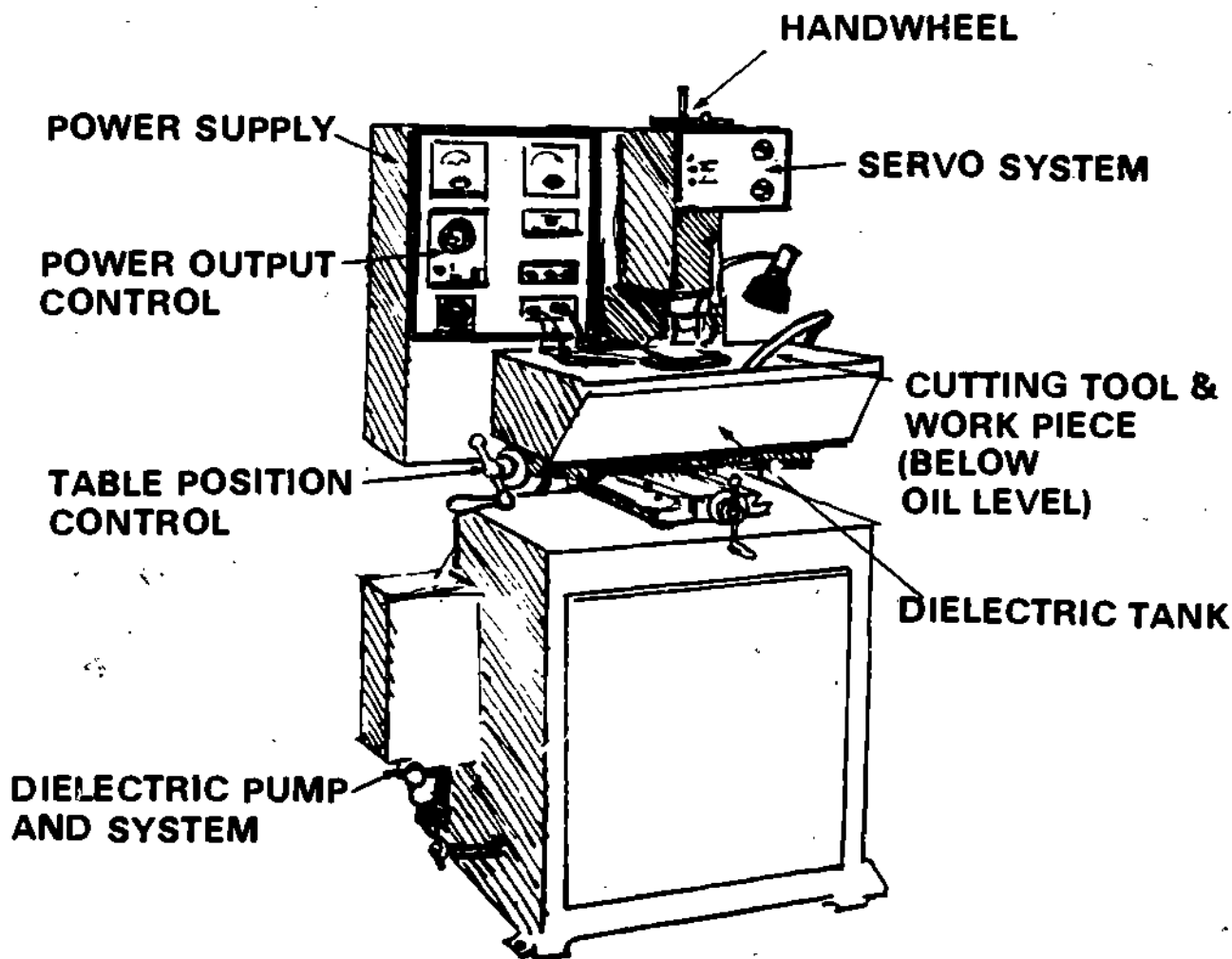

12.22

Electric Discharge Machine (EDM)

S _____

Name _____

Class _____

Date _____ Grade _____

Safety Quiz

(Circle True or False)

1. The tool must be discharged on completion of a cut. T F
2. Oil must cover the workpiece and the tank should be full before activating the power supply. T F
3. All spilled oil must be cleaned up, or wiped off the machine. T F
4. The tool voltage is not high enough to be dangerous. T F

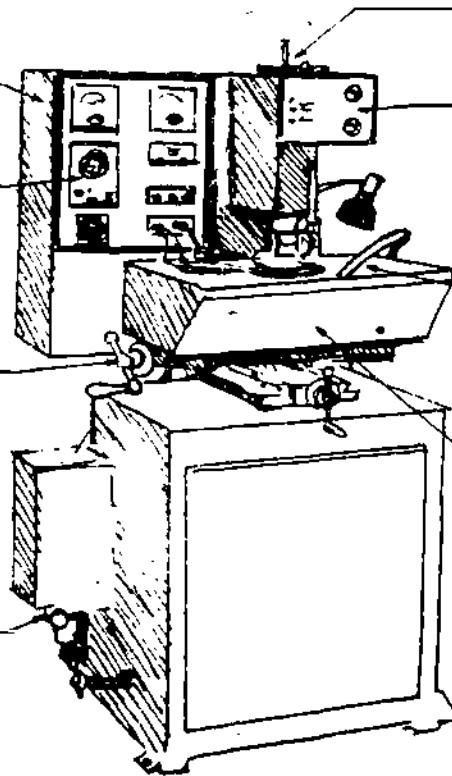

(Print the correct names)

12.23

For Safety —

1. Operate only with instructors permission and after you have received instruction.
2. Remove jewelry, eliminate loose clothing, and confine long hair.
3. Make sure all guards are in place and operating correctly.
4. Always use proper eye protection.
5. Clean up all fluid spillage.
6. Exercise caution when disconnecting fluid system.
7. Make sure all components are securely fastened, and properly connected before operating unit.

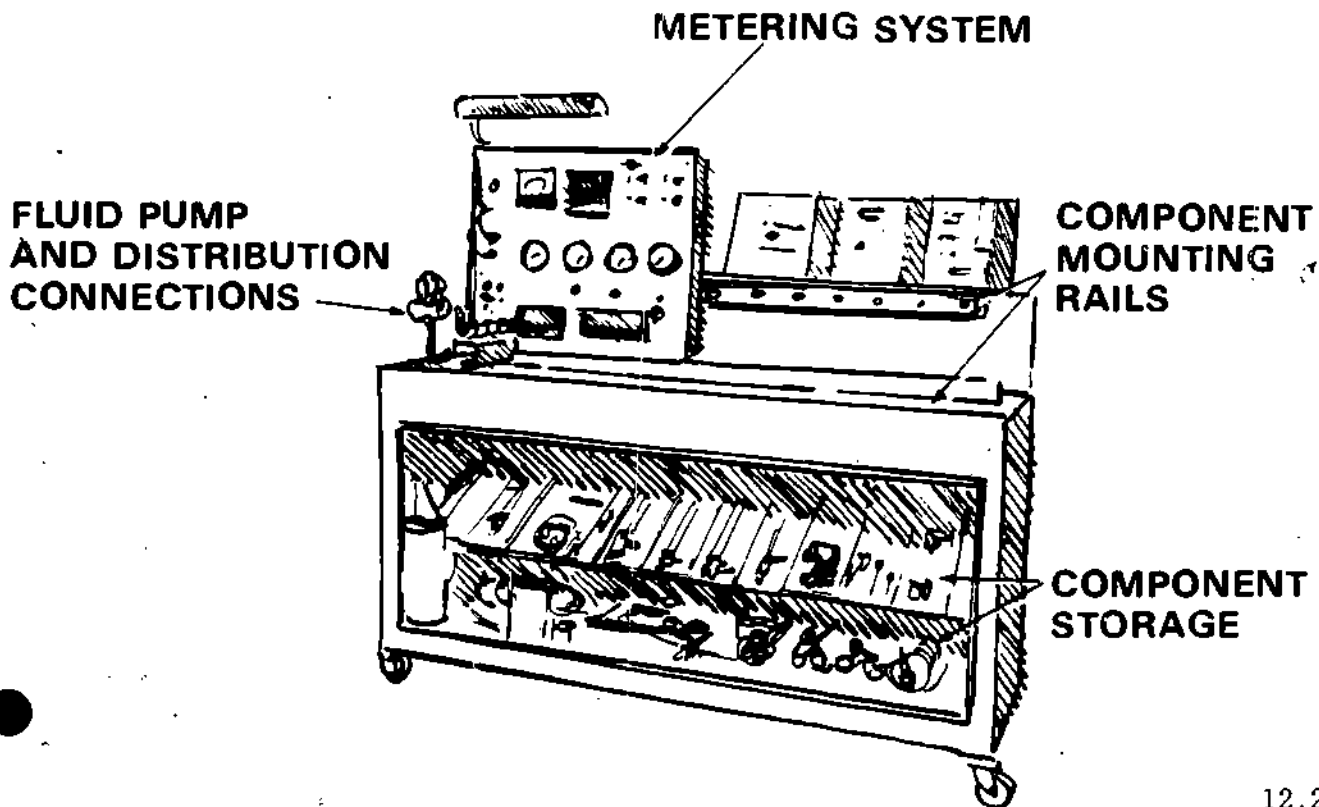

12.24

Hydraulic Training Unit

S _____

Name _____

Class _____

Date _____ Grade _____

Safety Quiz

(Circle True or False)

1. All components must be securely fastened before operating the unit. T F
2. Extreme caution must be used when disconnecting the components. T F
3. Eye protection is not required when operating this unit. T F
4. Fluid spills should be cleaned up immediately. T F

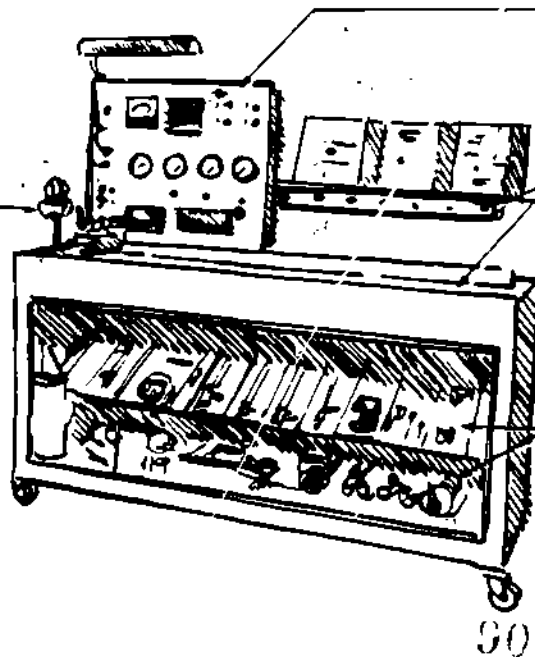

(Print the correct names)

12.25

For Safety —

1. Operate only with instructor's permission and after you have received instruction.
2. Remove jewelry, eliminate loose clothing, and confine long hair.
3. Make sure all guards are in place and operating correctly.
4. Always use proper eye protection.
5. The top must be open when lighting the forge.
6. Sequence directions for igniting air and gas must be followed exactly.
7. Asbestos gloves must be worn when tongs are not used.
8. Hot metal left unattended must be marked "HOT" with chalk.
9. When shutting down turn gas off first.

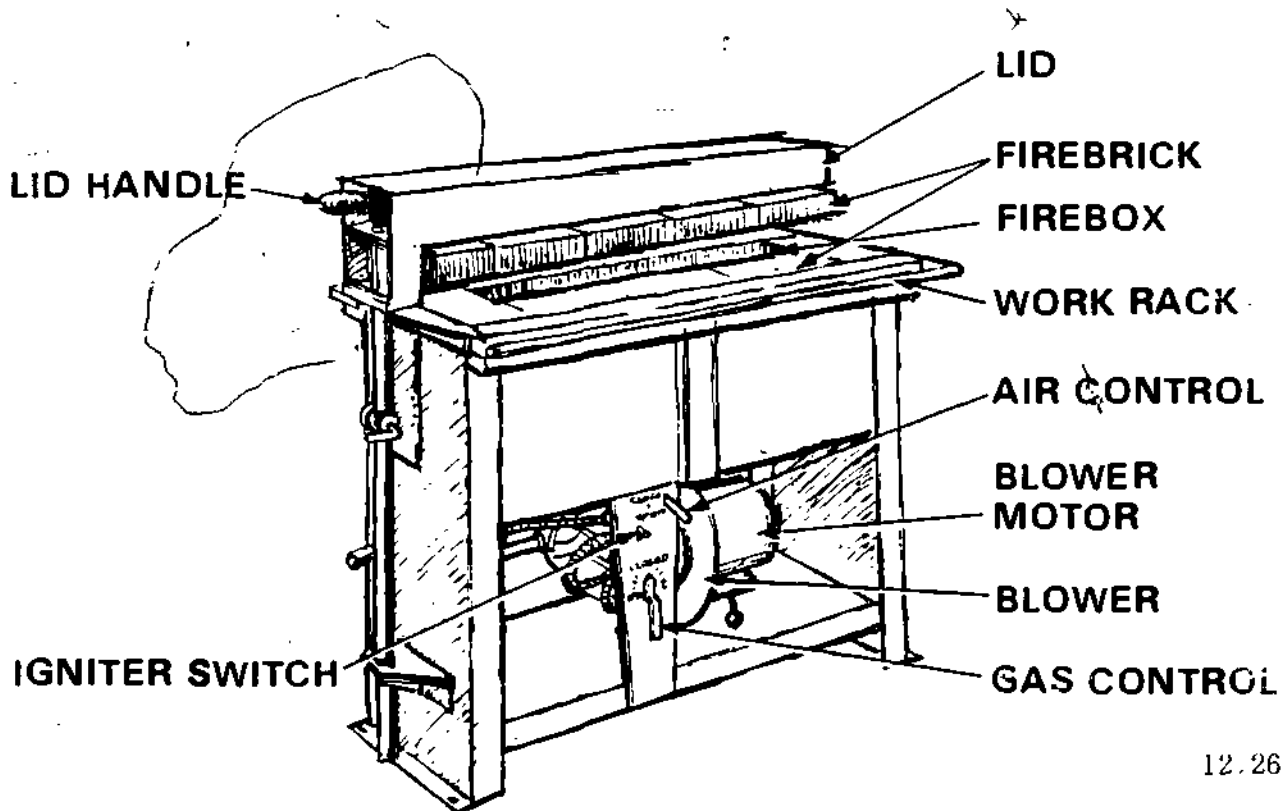

12.26

S _____

Name _____

Class _____

Date _____ Grade _____

Safety Quiz

(Circle True or False)

1. Tongs should be available for the handling of hot metal. T F
2. Gloves should be worn when handling the tongs. T F
3. The top slot should be closed when lighting the forge. T F
4. The air should be turned off first when shutting down. T F
5. Hot metal should be marked "HOT". T F

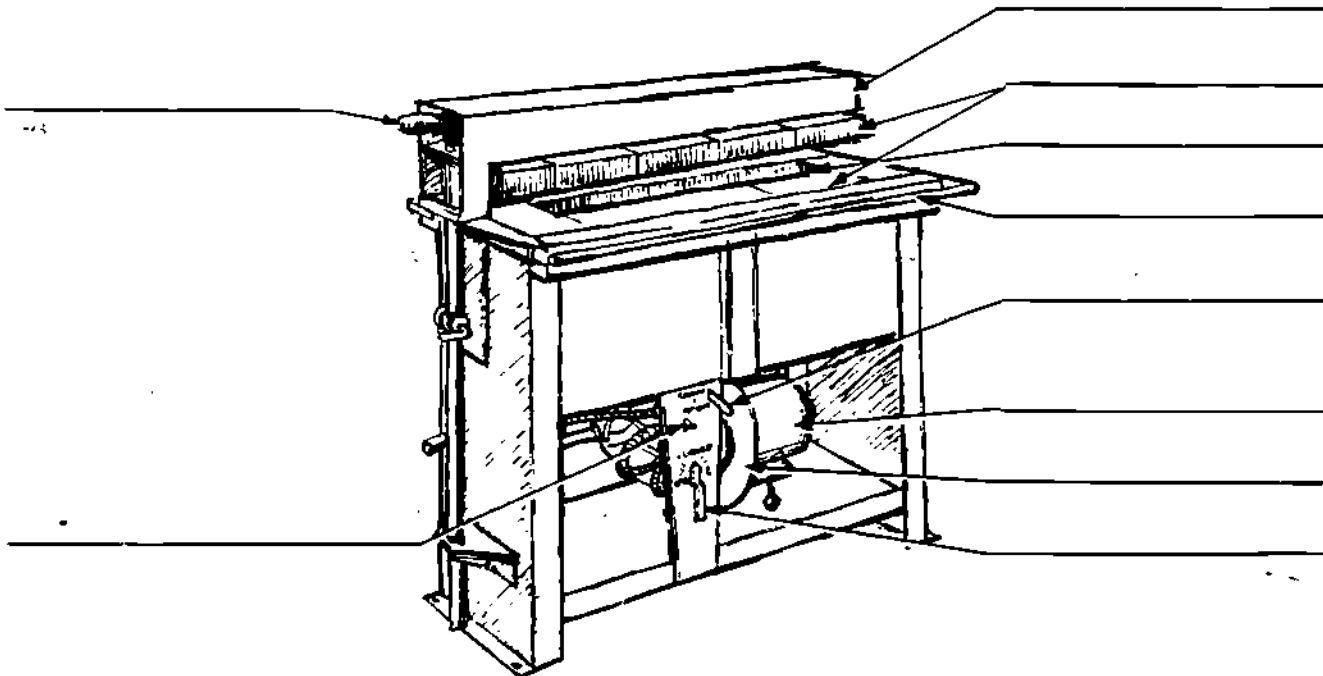

12.27
(Print the correct names)

For Safety —

1. Operate only with instructors permission and after you have received instruction.
2. Remove jewelry, eliminate loose clothing, and confine long hair.
3. Make sure all guards are in place and operating correctly.
4. Always use proper eye protection.
5. The tool rests must be adjusted to within 1/16" of the grinding wheel.
6. Spark deflectors must be adjusted to within 1/16" of the grinding wheels.
7. Do not grind on the side of the grinding wheels.
8. Stand to one side when starting the machine.
9. Discard or report grinding wheels that are excessively small or cracked.
10. Small work pieces should be held with "vise grip" type pliers.
11. Do not leave the machine until the grinding wheels have come to a full stop.

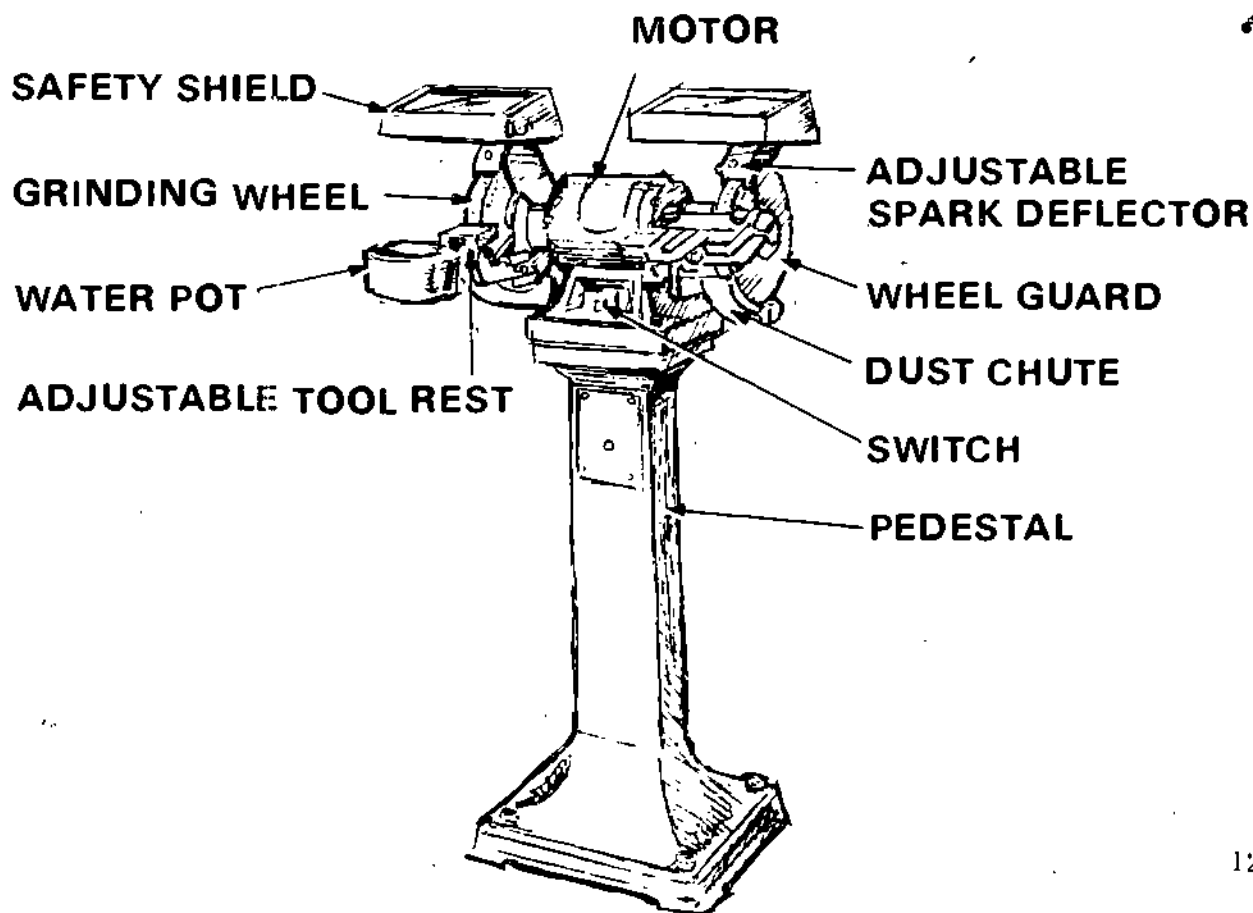

12.28

S _____

Name _____

Class _____

Date _____ Grade _____

Safety Quiz

(Circle True or False)

1. The tool rest should be adjusted to within 1/2" of wheel. T F
2. Eye protection is always necessary while grinding. T F
3. Once the "off" switch is in the off position, the operator may leave. T F
4. Wheels that are slightly cracked may be used. T F
5. The spark arrestor is not necessary if there is a safety shield. T F
6. When grinding a small piece of steel, "vise grips" are advised. T F

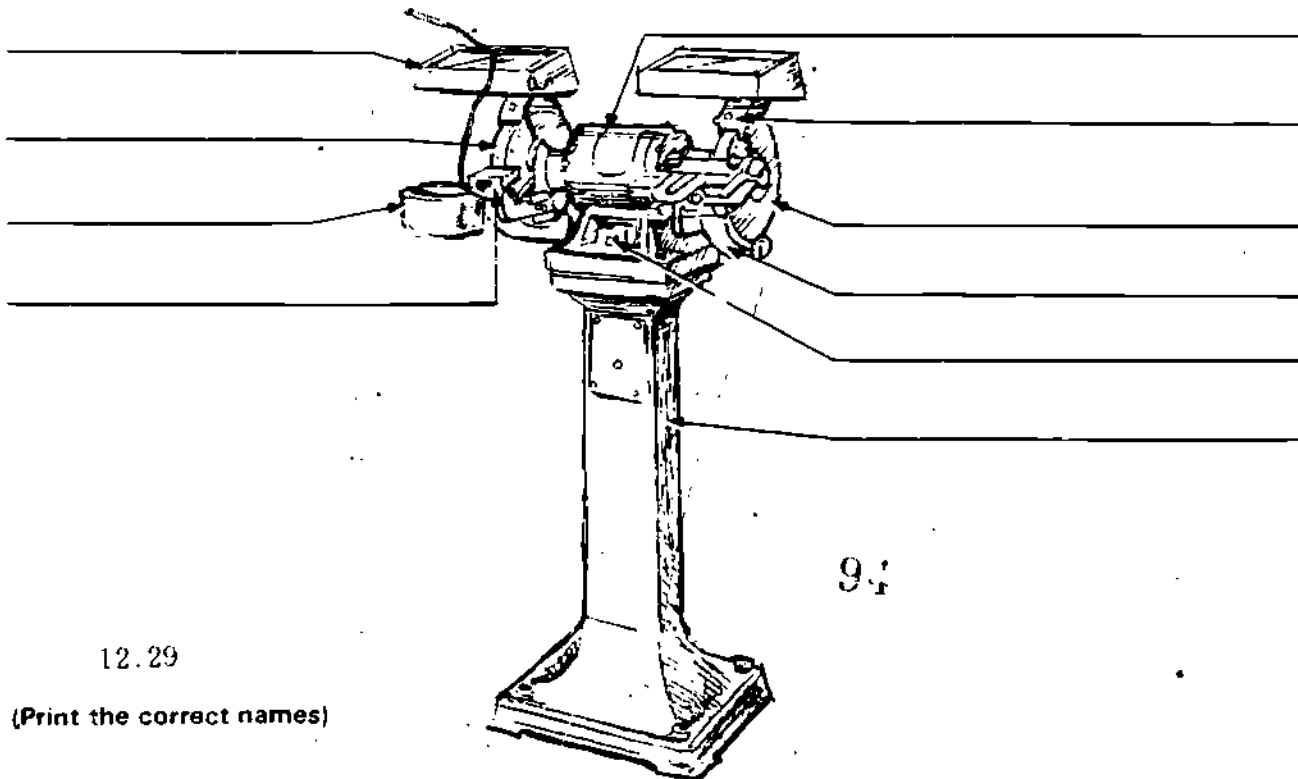

12.29

(Print the correct names)

For Safety —

1. Operate only with instructors permission and after you have received instruction.
2. Remove jewelry, eliminate loose clothing, and confine long hair.
3. Make sure all guards are in place and operating correctly.
4. Always use proper eye protection.
5. All adjustments to the chip removal brushes, blade tension, guides, vise, or drive system should be done with the power off.
6. Be sure blade guides are properly adjusted to both the blade and the work size or vise before starting cut.
7. Adjust feed rate so blade does not bounce or plunge into work when starting the cut.
8. Be sure work is tightly clamped in the vise and properly positioned for an efficient safe cut.
9. Keep hands away from cutting area and brush away chips only when the machine is turned off.
10. If the material requires coolant be sure the system is working and the correct coolant is used.

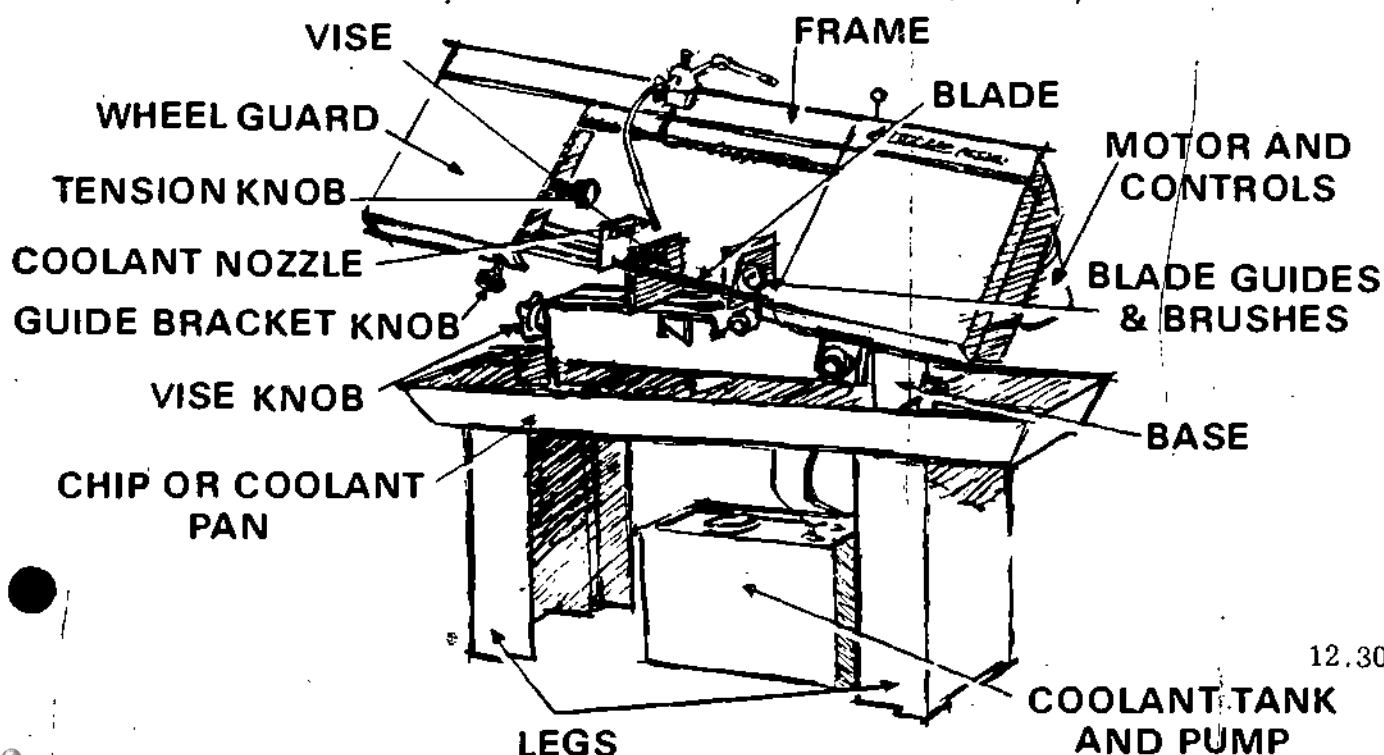

12.30

Horizontal Band Saw

S _____

Name _____

Class _____

Date _____ Grade _____

Safety Quiz

(Circle True or False)

1. Chips or dirt in the vise may cause inaccuracy but does not affect safety. T F
2. It is safe to apply slight pressure to the saw frame to increase the speed of the cutting action. T F
3. Blade guides should be adjusted to the blade and to the size of the work piece or vise. T F
4. Chips should be removed only when the machine is stopped. T F
5. If the cut is not straight the problem is probably with the material. T F
6. The work piece must be properly positioned in the vise, in addition to just being held securely. T F

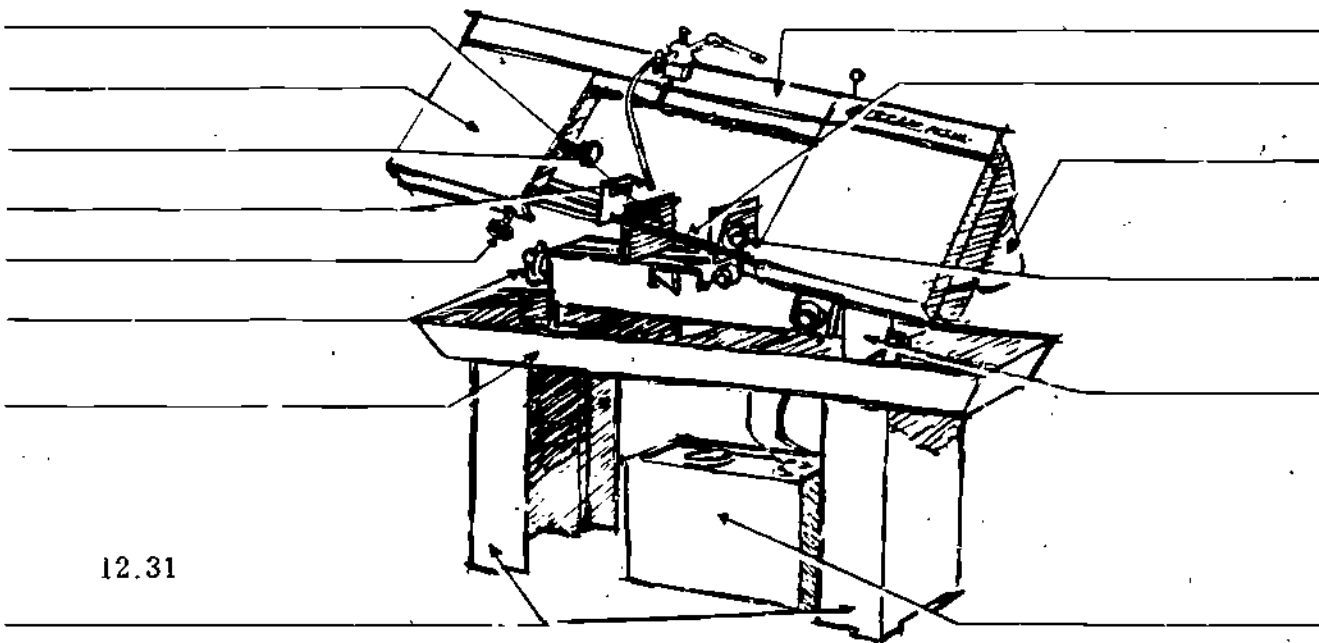

12.31

For Safety —

1. Operate only with instructors permission and after you have received instruction.
2. Remove jewelry, eliminate loose clothing, and confine long hair.
3. Make sure all guards are in place and operating correctly.
4. Always use proper eye protection.
5. Make all adjustments with the power off.
6. Be sure cutter is tightly held in arbor or collet and material is securely held by a vise, clamps, or magnetic chuck.
7. Do not climb cut with out specific permission.
8. Check depth and width of cut, cutter rotation, plus speed of cutter and power feed before starting the machine.
9. Never clear chips away while machine is in operation. Keep hands away from chips and the point of operation.
10. Remain with the machine for the duration of the cut.

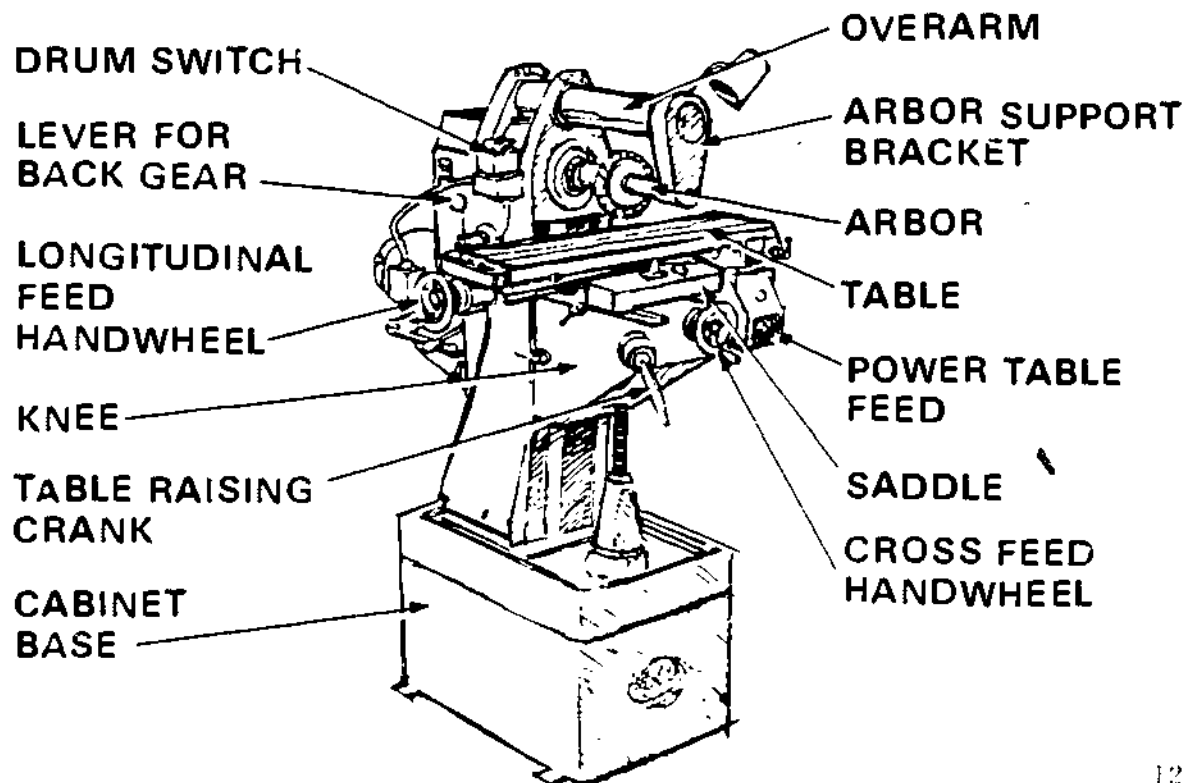

12.32

Horizontal Milling Machine

s

Name _____

Class _____

Date _____ Grade _____

Safety Quiz

(Circle True or False)

1. Small chips can be safely wiped away by hand if the machine is stopped. T F
2. While on automatic or power feed it is permissible to leave the machine. T F
3. Permission must be obtained to climb cut. T F
4. Since they are very sharp, cutters should be handled carefully. T F
5. All adjustments must be made or checked with the power off. T F

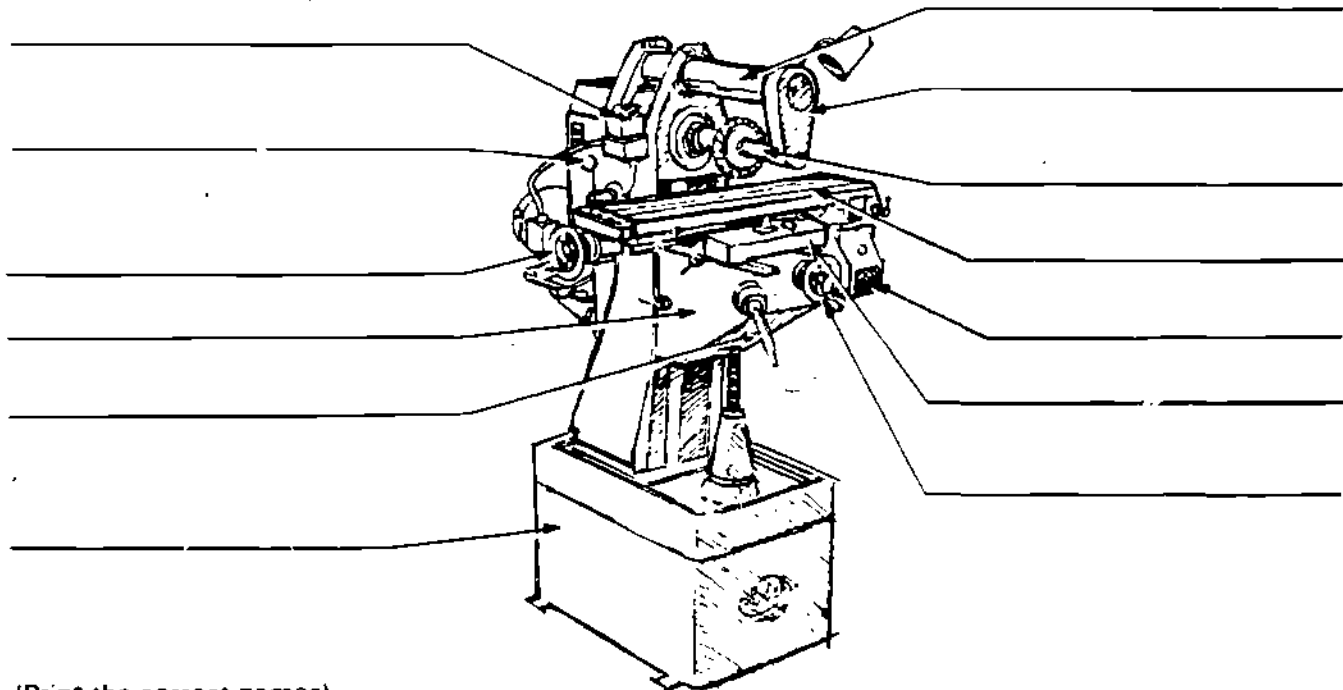

(Print the correct names)

12.33

90

For Safety —

1. Operate only with instructors permission and after you have received instruction.
2. Remove jewelry, eliminate loose clothing, and confine long hair.
3. Make sure all guards are in place and operating correctly.
4. Always use proper eye protection.
5. Make all adjustments with the power turned off.
6. A push stick or push block must be used when hands would pass over-or within 2" of the cutter head.
7. Make several light cuts (1/16" to 1/8") instead of one heavy cut (1/2").
8. The absolute minimum length of material that may be jointed is twice the size of the knives - 6" jointer, 12" - 8" jointer, 16".
9. Do not adjust or move the rear or out feed table without permission

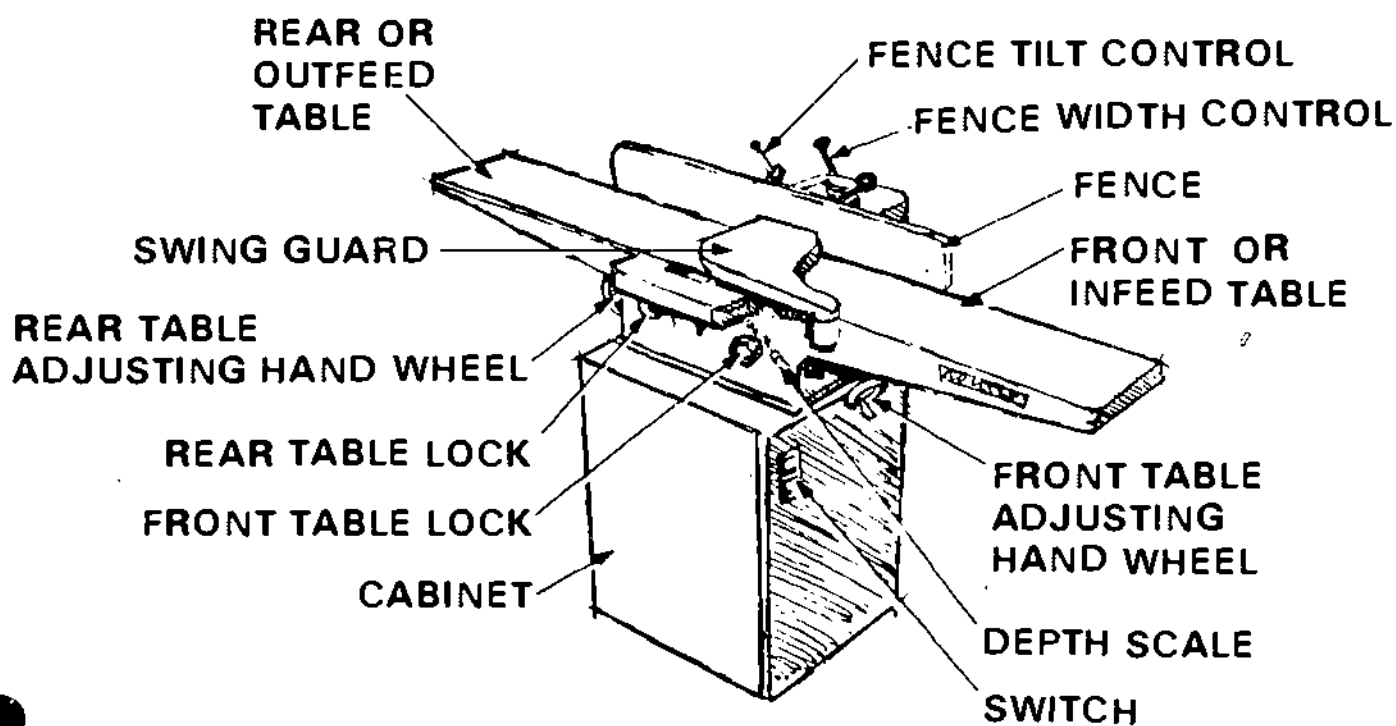

10-81

S _____

Name _____

Class _____

Date _____ Grade _____

Safety Quiz

(Circle True or False)

- 1. It is possible for the guard to stick and not cover the cutter. T F
- 2. A push stick should be used when the hands could get close to the cutter. T F
- 3. Eye protection is not necessary when operating a jointer. T F
- 4. Permission should be obtained before using the jointer. T F
- 5. Stock shorter than 6" may be processed on the jointer. T F
- 6. In order to remove 3/8" you should make three passes 1/8" deep. T F

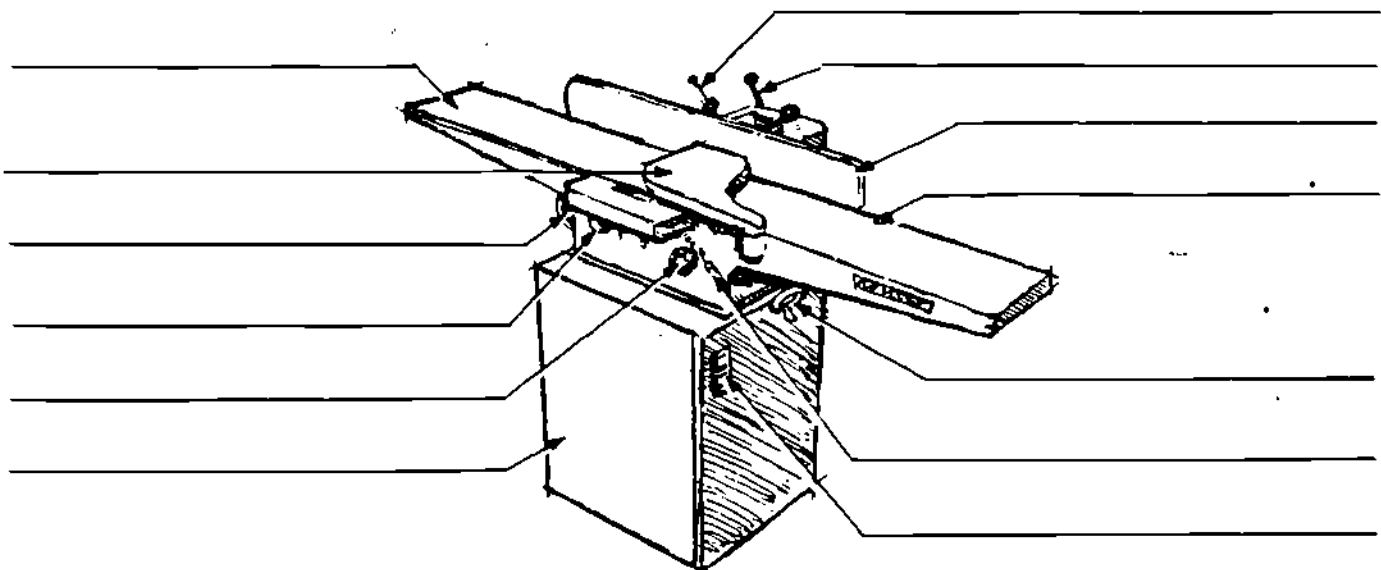

12.35

(Print the correct names)

For Safety —

1. Operate only with instructors permission and after you have received instruction.
2. Remove jewelry, eliminate loose clothing, and confine long hair.
3. Make sure all guards are in place and operating correctly.
4. Always use proper eye protection.
5. Never leave the chuck key in the lathe chuck.
6. Rotate spindle by hand to check clearance before engaging power.
7. Remove chips with a brush, never by hand.
8. Make sure work is secure and lathe is set at correct speed and feed before starting cut.
9. Handle chucks and face plates carefully. Never adjust tool bit when tool holder is hand held.
10. Remove tool holder and tool post before filing or polishing.
11. Do not hand stop a lathe chuck, allow it to coast to a stop. Keep hands away from all moving parts.

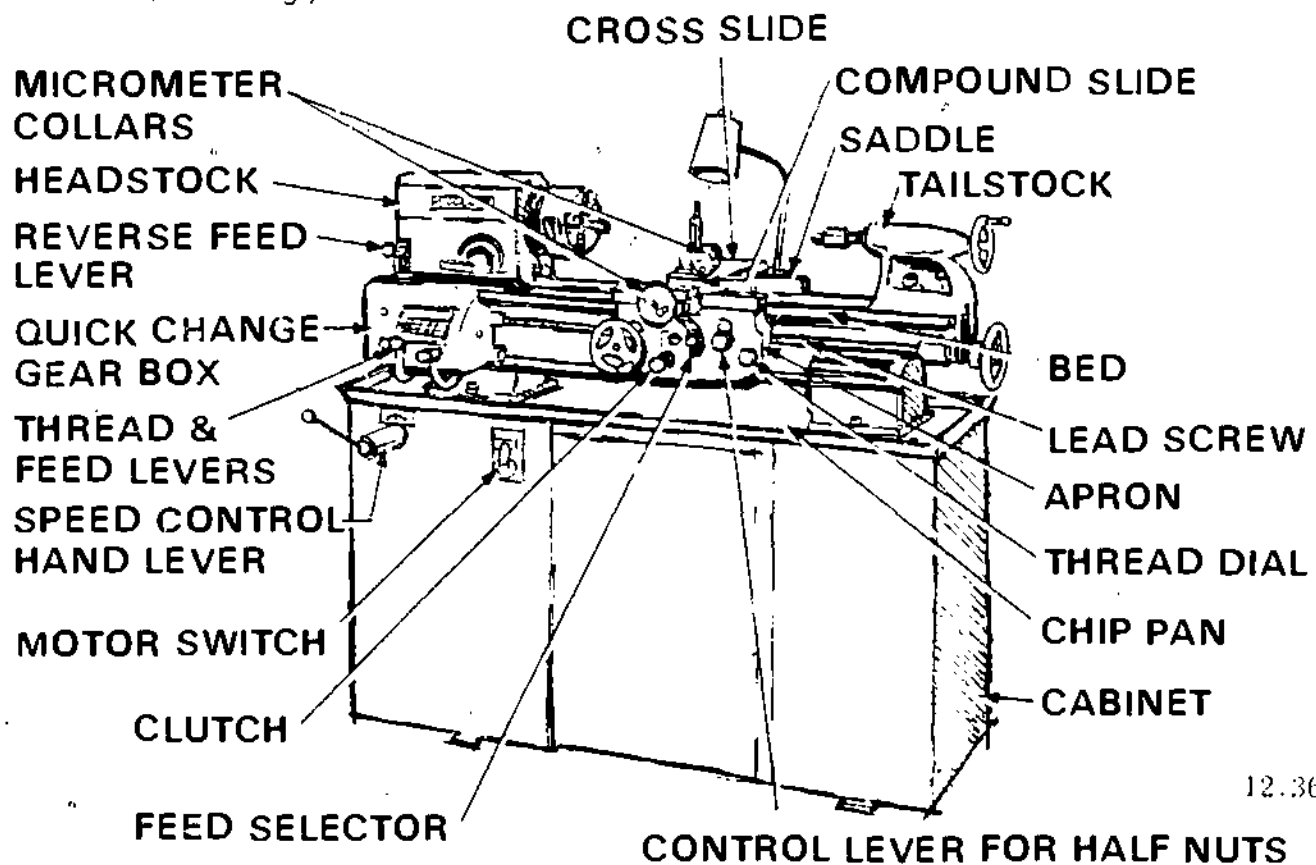

12.36

S _____

Name _____

Class _____

Date _____ Grade _____

Safety Quiz

(Circle True or False)

1. A brush should be used for removing chips. T F
2. The tail stock need not be secured to the bed. T F
3. The chuck wrench remains in the chuck when the machine is stopped. T F
4. It is safe to turn machine by hand before starting. T F
5. Measurements should be made while the machine is stopped. T F
6. The tool bit should be adjusted only when the tool holder is locked in the tool post. T F

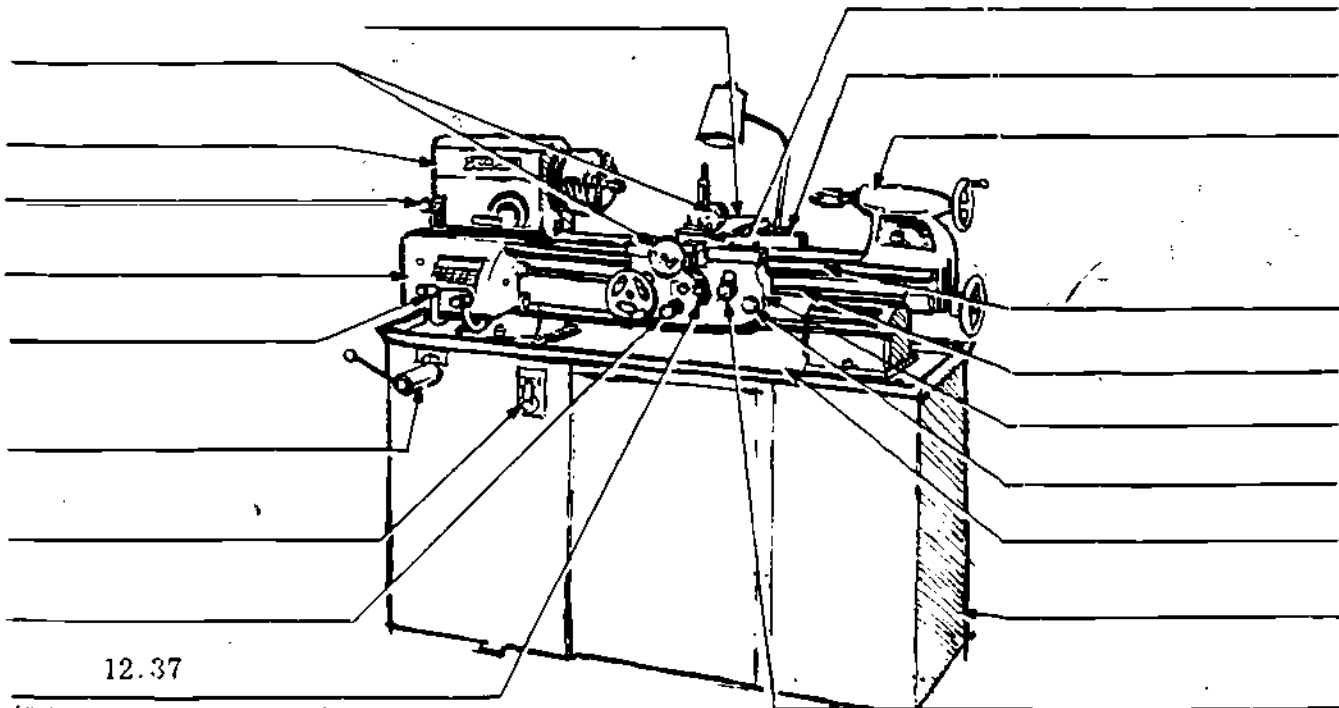

12.37

(Print the correct names)

For Safety —

1. Operate only with instructors permission and after you have received instruction.
2. Remove jewelry, eliminate loose clothing, and confine long hair.
3. Make sure all guards are in place and operating correctly.
4. Always use proper eye protection.
5. Make adjustments while the machine is stopped and run through one cycle by hand as a check for clearance.
6. Make sure all guards are secure before starting the machine.
7. Be sure the work piece is securely held in the vise or holding device.
8. Avoid standing directly in front of the ram.
9. Keep hands away from the work point or possible pinch point of the shaper.
10. Do not lay tools or tooling on any-part of the machine.
11. Never remove chips while the machine is in motion.
12. Before leaving make sure the shaper comes to a full stop.

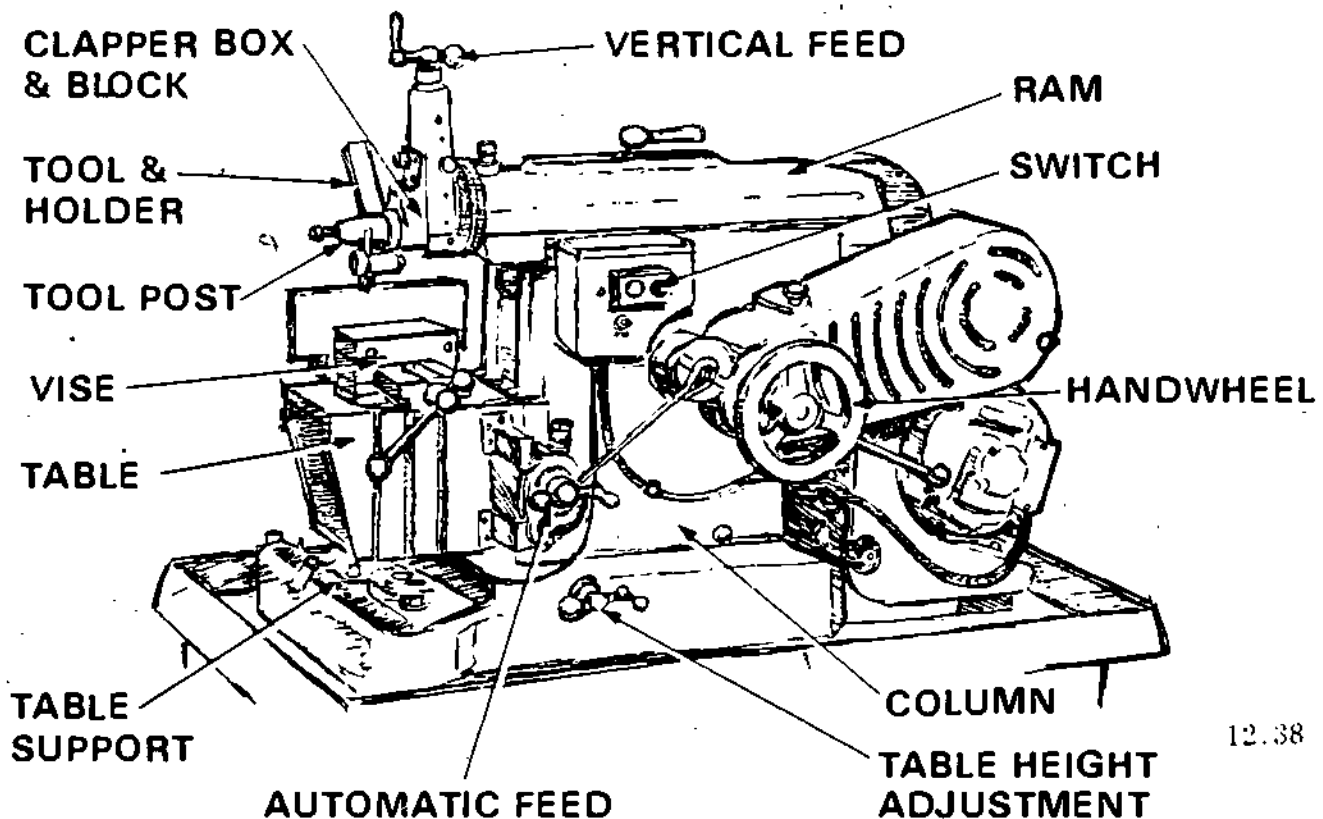

12.38

S _____

Name _____

Class _____

Date _____ Grade _____

Safety Quiz

(Circle True or False)

1. It is permissible to stand in front of the machine while it is running. T F
2. Eye protection must be worn. T F
3. A heavy cut may get the job done more quickly but also could be unsafe. T F
4. Chips may be quickly removed while the machine is running. T F
5. All clearances should be checked before the ram is set in motion. T F
6. All set-ups should be approved by your instructor. T F

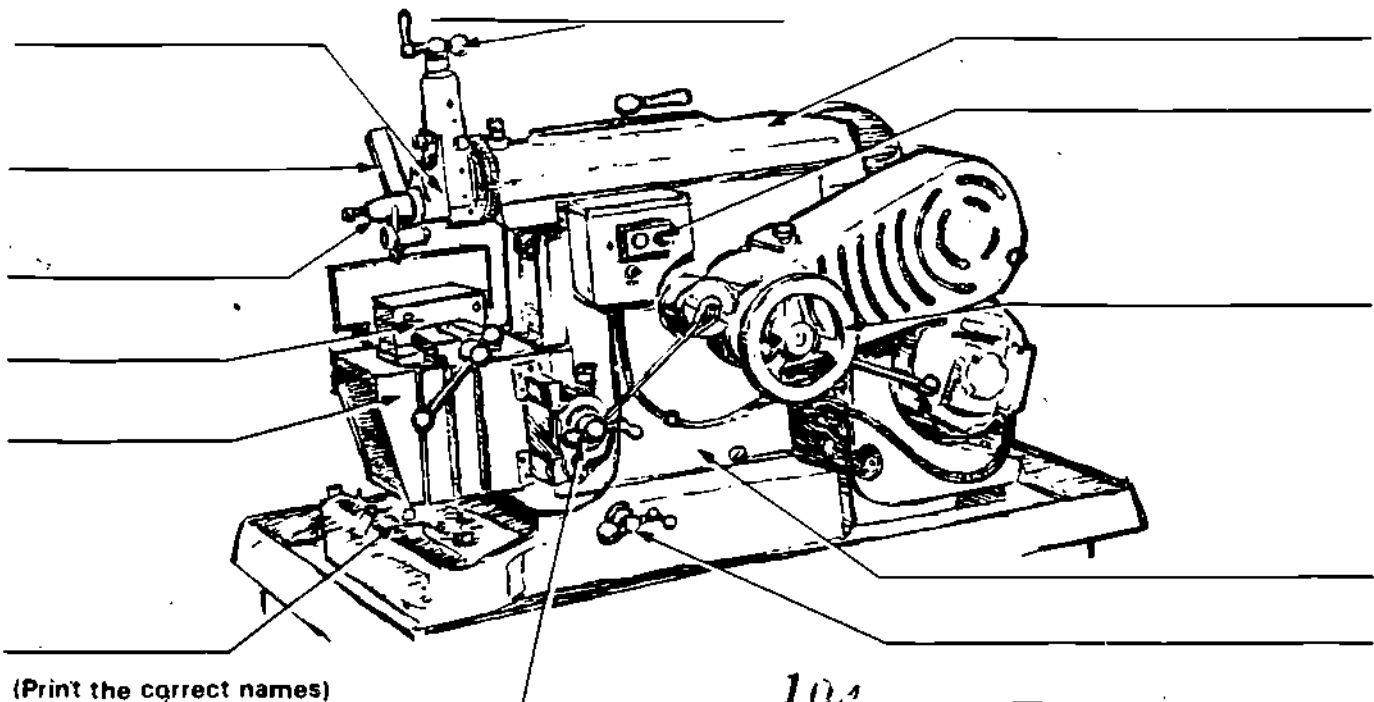

(Print the correct names)

12.39

For Safety —

1. Operate only with instructors permission and after you have received instruction.
2. Remove jewelry, eliminate loose clothing, and confine long hair.
3. Make sure all guards are in place and operating correctly.
4. Always use proper eye protection.
5. Be sure power is disconnected before making angle adjustments or changing blades.
6. Always hold the work firmly against the fence and table.
7. Install a new table if adequate support has been cut away.
8. Allow the motor to reach full speed before starting to cut.
9. Use the brake to stop the blade before removing scrap or chips from the work area.
10. Be sure guard parts are functioning properly.

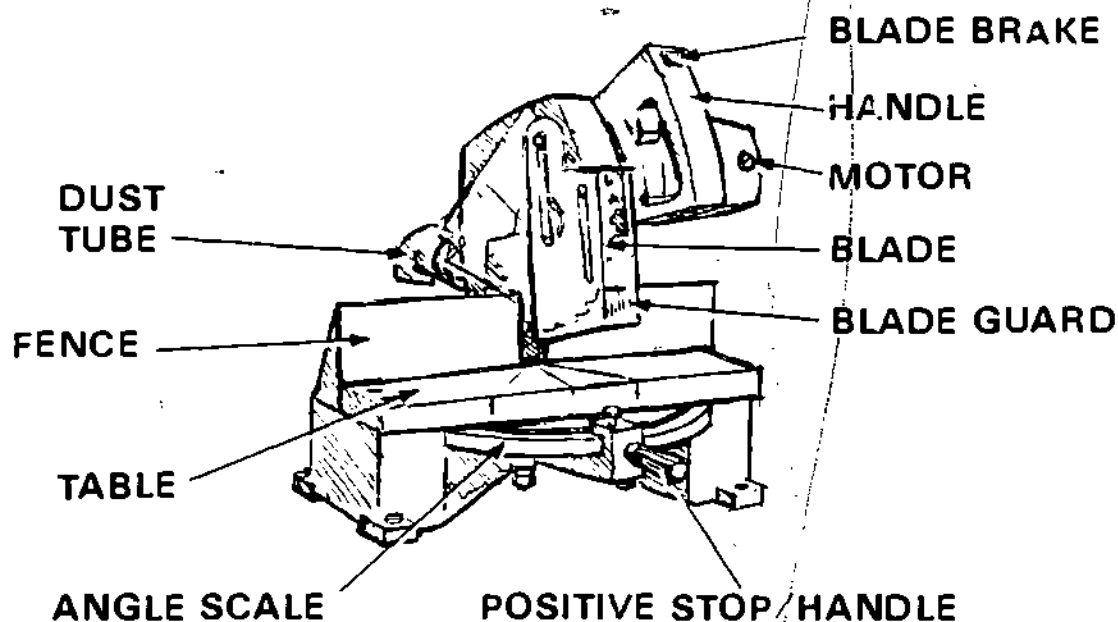

12.40

S _____

Name _____

Class _____

Date _____ Grade _____

Safety Quiz

(Circle True or False)

1. The table on this machine can be cut so often that it no longer gives safe support to the work. T F
2. The machine should be stopped by pushing a piece of scrap against the side of the blade. T F
3. The guard sections can easily be checked for proper operation before starting to use the machine. T F
4. The trigger switch and the brake button can be used together to gain better control. T F
5. A warped or twisted work piece is not really dangerous. T F

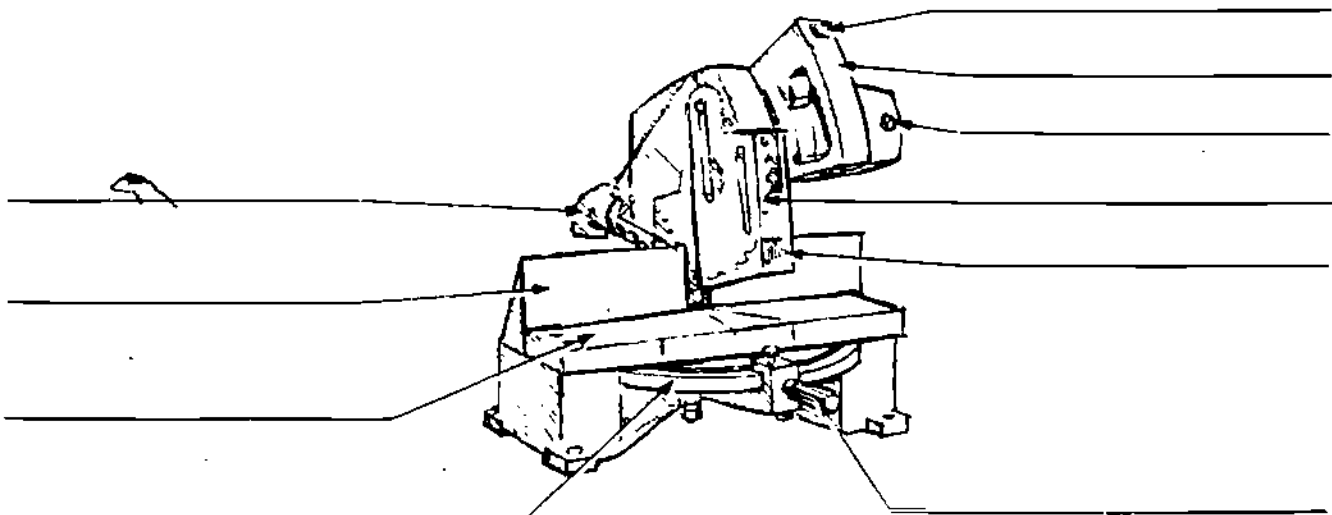

12.41
(Print the correct names)

For Safety —

1. Operate only with instructors permission and after you have received instruction.
2. Remove jewelry, eliminate loose clothing, and confine long hair.
3. Make sure all guards are in place and operating correctly.
4. Always use proper eye protection.
5. Never reach for misprinted or dropped paper while the press is in operation.
6. Do not make internal adjustments while the press is in operation.
7. Do not clean the press while it is in operation.
8. The instructor should determine the operating speed.
9. Never reach across the press while it is in operation.
10. When finished with the press, it must be clean and all paper, equipment and tools must be returned to proper storage.

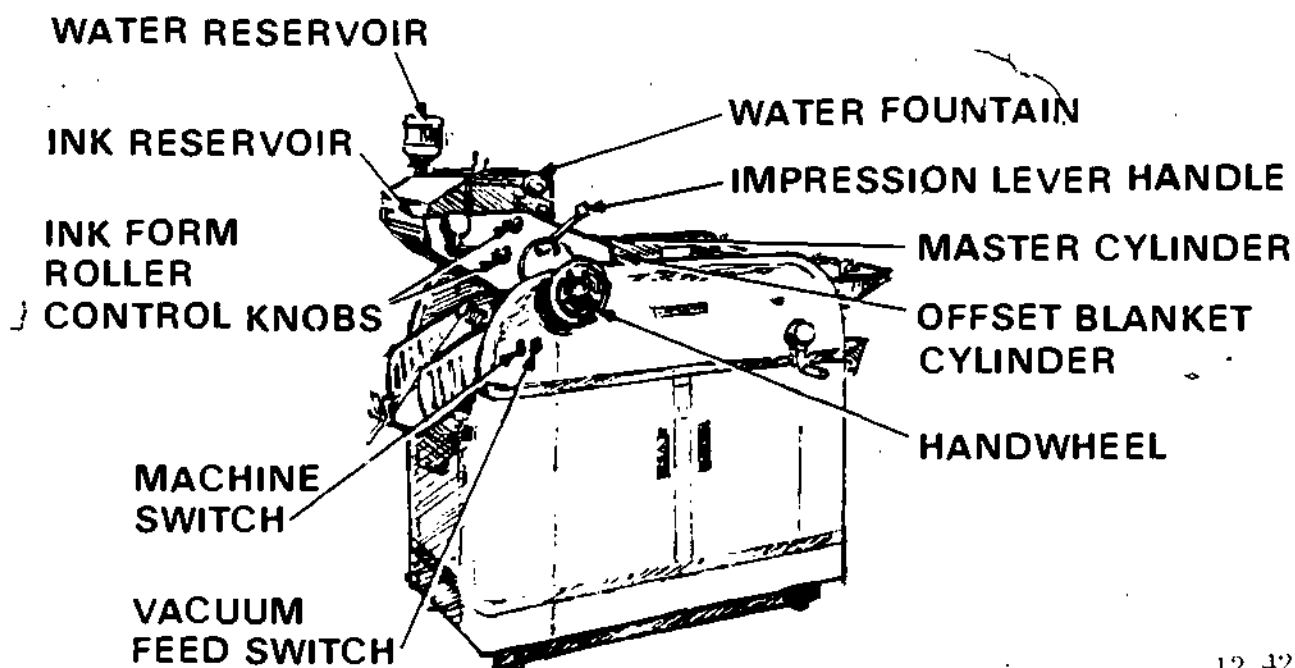

12.42

Offset Printing Press

S _____

Name _____

Class _____

Date _____ Grade _____

Safety Quiz

(Circle True or False)

1. The gears need not be covered while the press is in operation. T F
2. The machine must be stopped before misprinted or dropped paper is removed from the press. T F
3. Final adjustments may be made while the machine is running. T F
4. You should be alert to keeping others away from the press while it is in operation. T F
5. It is safe to reach across the press when it is operating. T F

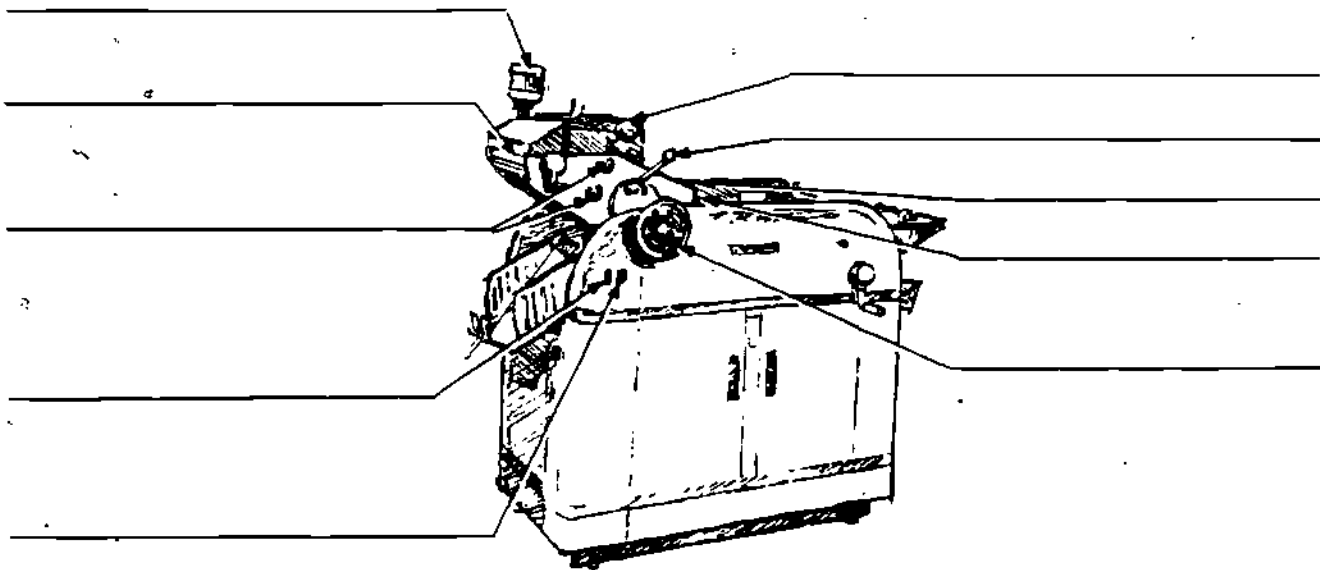

(Print the correct names)

12.43

100

For Safety —

1. Operate only with instructors permission and after you have received instruction.
2. Remove jewelry, eliminate loose clothing, and confine long hair.
3. Make sure all guards are in place and operating correctly.
4. Always use proper eye protection.
5. Make all adjustments to the table, fence, overarm and spindle with the power turned off.
6. Disconnect from power source when changing cutters or bits.
7. Check set up carefully before starting operation to be sure cutter clears the table, fence and any fixtures.
8. Be sure guard is in place before starting cut.
9. Feed material against the direction of rotation when ever possible.
10. When pin routing make sure pin or table insert is tight and the work piece is secure in the jig.

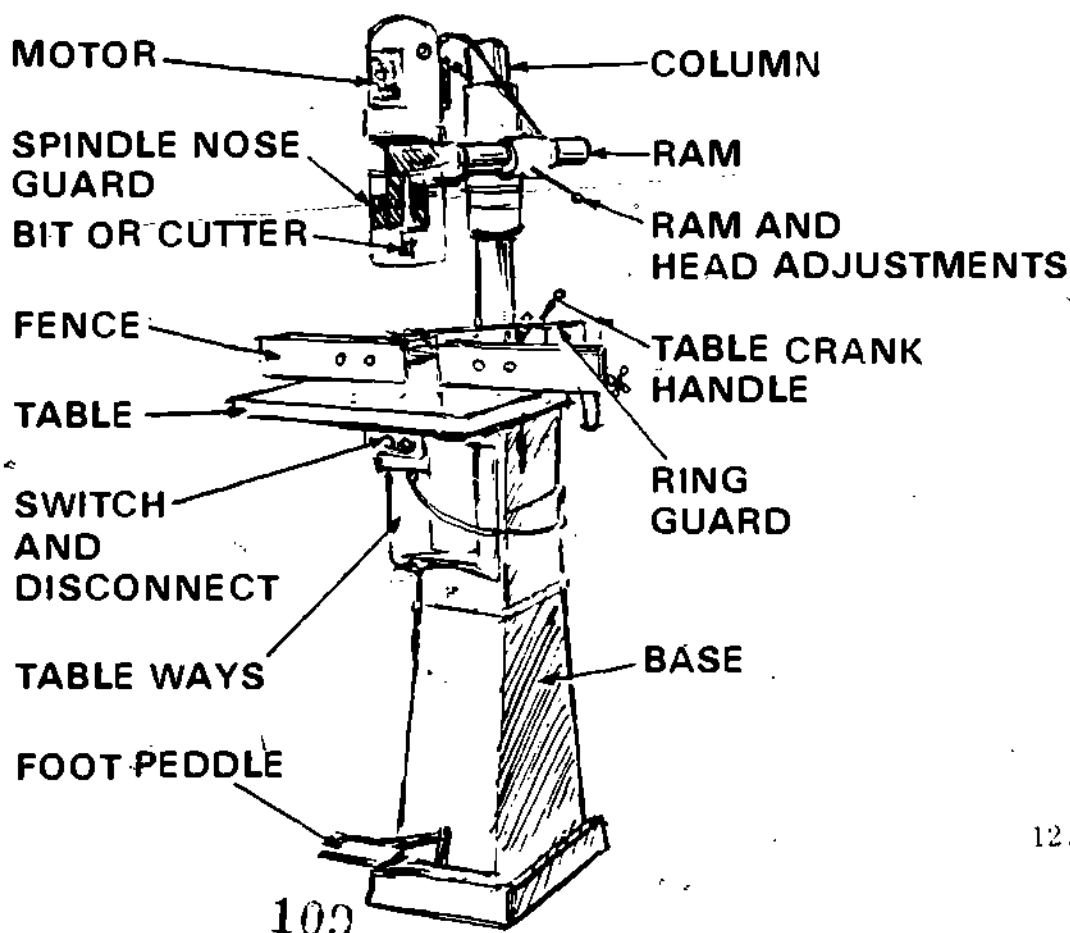

Overarm Router

S _____

Name _____

Class _____

Date _____ Grade _____

Safety Quiz

(Circle True or False)

1. When shaping or routing a jogging motion will give a smoother cut. T F
2. Special or custom jigs or fixtures are necessary for some operations. T F
3. The machine must be disconnected from the power source when changing bits. T F
4. The speed of this machine is about 5 thousand RPM. T F
5. Both hands should be used to more or control the work piece. T F

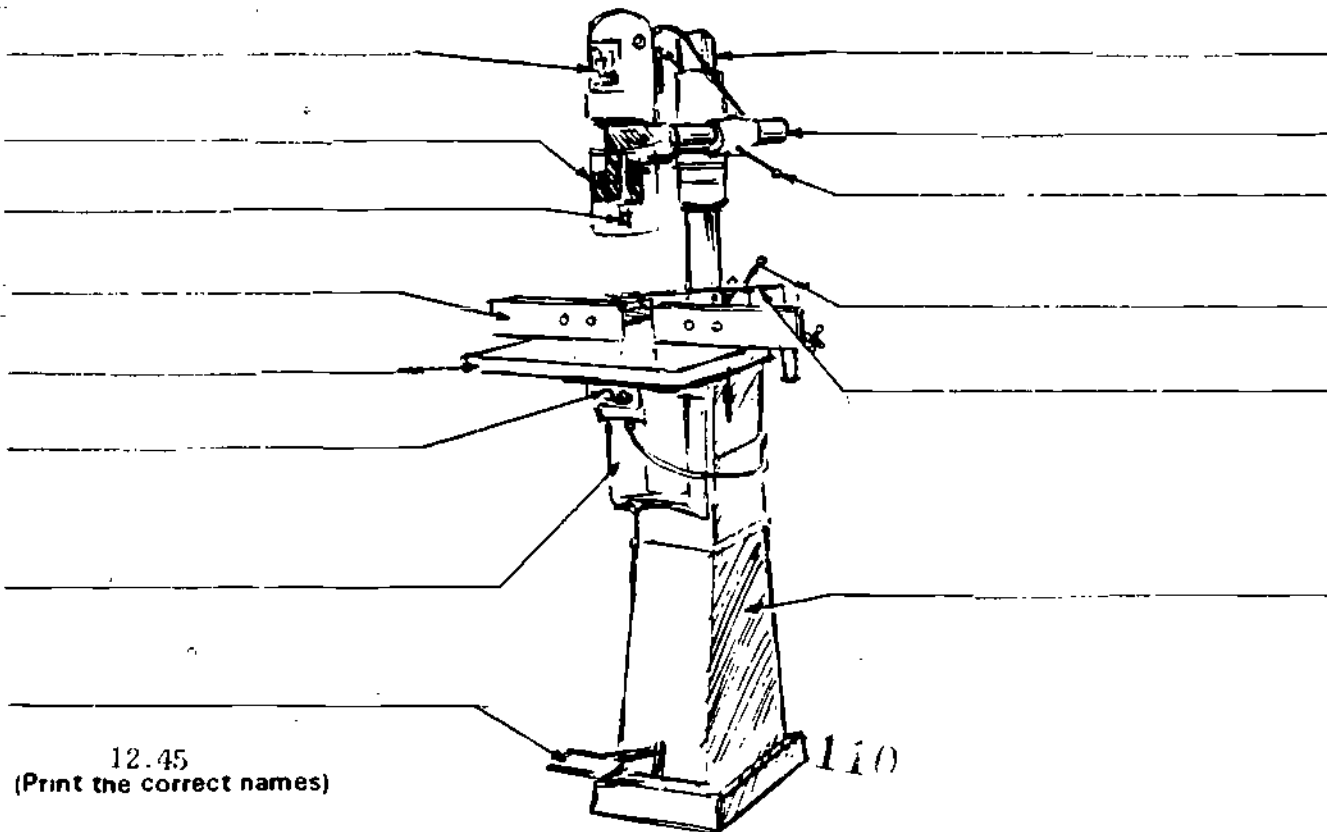

12.45
(Print the correct names)

For Safety —

1. Operate only with instructors permission and after you have received instruction.
2. Remove jewelry, eliminate loose clothing, and confine long hair.
3. Make sure all guards are in place and operating correctly.
4. Always use proper eye protection.
 1. Do not allow oil to come in contact with hoses or equipment.
 2. Gas bottles must be erect and secure at all times.
 3. Keep the cylinder caps on the bottles when not in use.
4. Protective goggles and spark-resistant clothing must be worn when welding.
5. Confine all cutting and welding to the designated area in the shop.
6. Do not weld galvanized metal without proper ventilation.
7. Do not weld or cut on a closed container without instructor's approval.
8. The acetylene must never exceed 15 psi outlet pressure.
9. Turn off torch valves when finished with equipment.
10. Turn off gas and oxygen at tanks or stations at the end of class session.

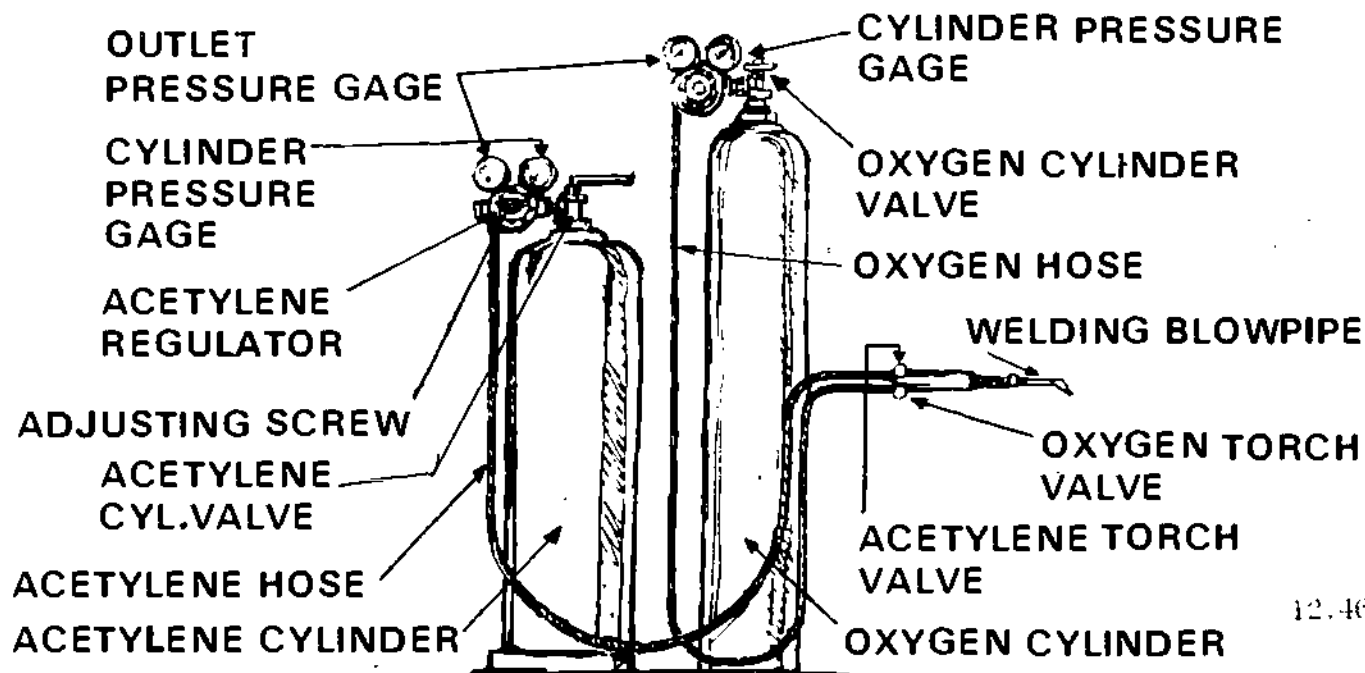

12.46

Oxy-Acetylene Welder

S _____

Name _____

Class _____

Date _____ Grade _____

Safety Quiz

(Circle True or False)

1. Gas bottles may be laid on the floor when not in use. T F
2. Closed containers are not hazardous to weld or repair. T F
3. The cylinder caps should be placed on all bottles when not in use. T F
4. Eye protection must be worn for all welding, cutting and chipping operations. T F
5. The equipment should not be wiped down with oily rags. T F
6. Acetylene pressure should be set at 20 psi. T F

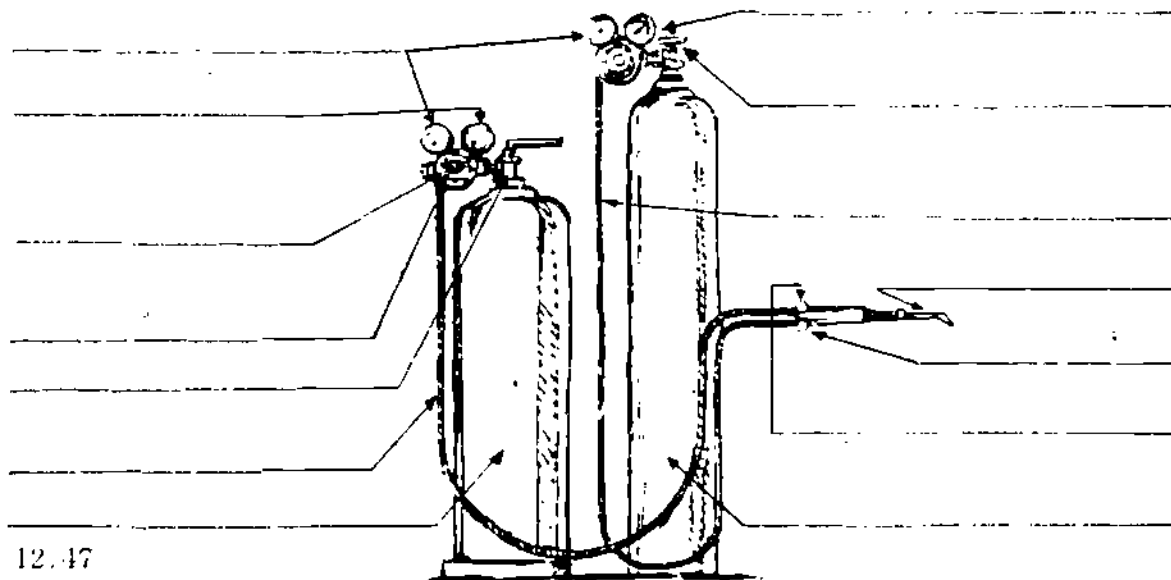

12.47

(Print the correct names)

112

For Safety —

1. Operate only with instructors permission and after you have received instruction.
2. Remove jewelry, eliminate loose clothing, and confine long hair.
3. Make sure all guards are in place and operating correctly.
4. Always use proper eye protection.
5. Changing or adjusting of the knife must be done by the instructor only.
6. All items other than the paper to be cut must be kept off the tables.
7. Both hands must be kept on the controls during the complete clamping and cutting cycle.
8. Floor area around the machine and controls must be clear of trimmings.
9. All adjustment of the machine, positive stops or guides must be made with the power off.

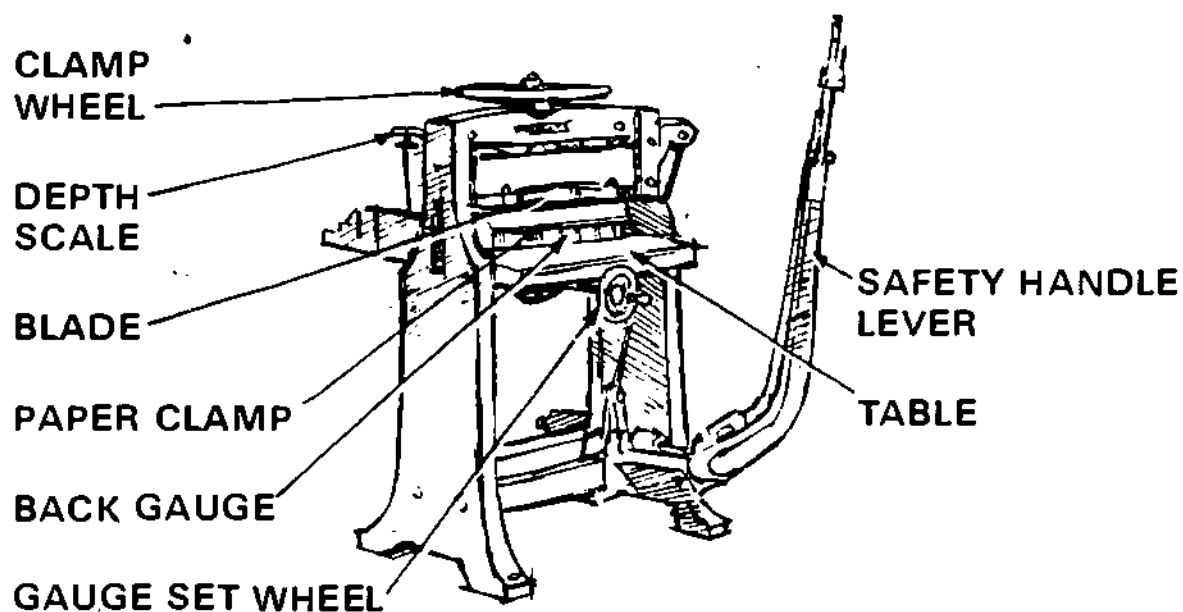

S _____

Name _____

Class _____

Date _____ Grade _____

Safety Quiz

(Circle True or False)

- 1. Since there are no chips involved, safety glasses are not required to operate this machine. T F
- 2. The floor must be kept clean around the paper cutter. T F
- 3. It is alright to cut thin gage metal on this machine. T F
- 4. Stops or gages should be adjusted only when the machine is turned off. T F
- 5. Hands should always be kept clear of the clamp and the cutter. T F

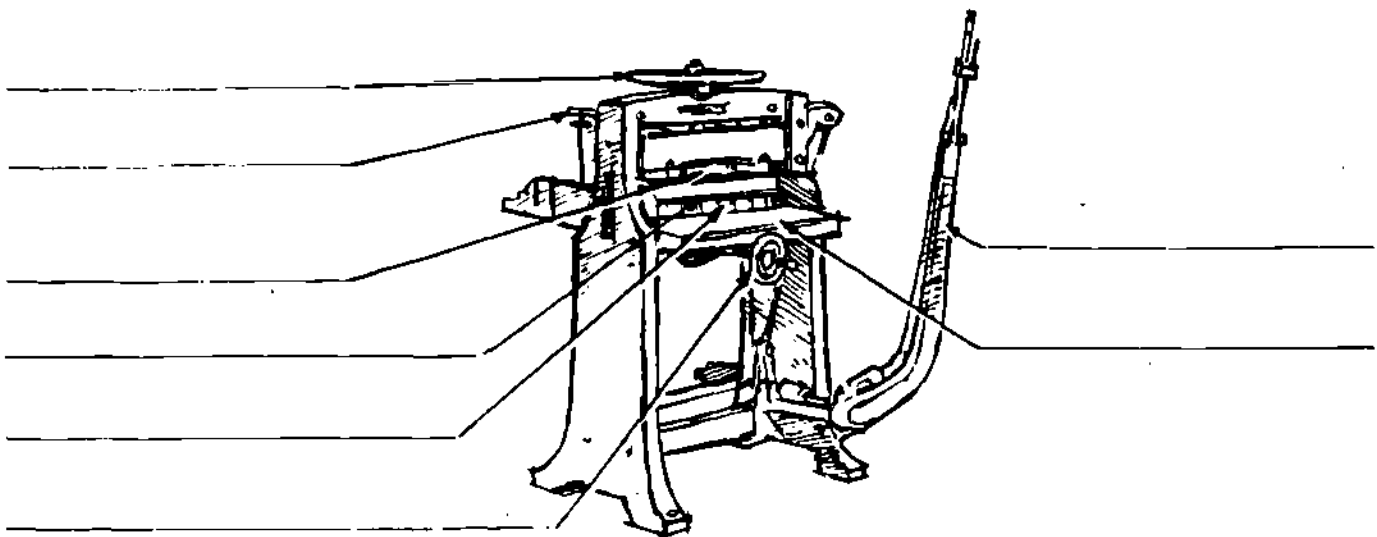

12.49
(Print the correct names)

For Safety —

1. Operate only with instructors permission and after you have received instruction.
2. Remove jewelry, eliminate loose clothing, and confine long hair.
3. Make sure all guards are in place and operating correctly.
4. Always use proper eye protection.
5. Be sure power is disconnected when making adjustment.
6. Keep hands clear of drilling area.
7. Be sure only one individual operates the unit.
8. Never touch the drill immediately following the drilling operation since it could be hot.

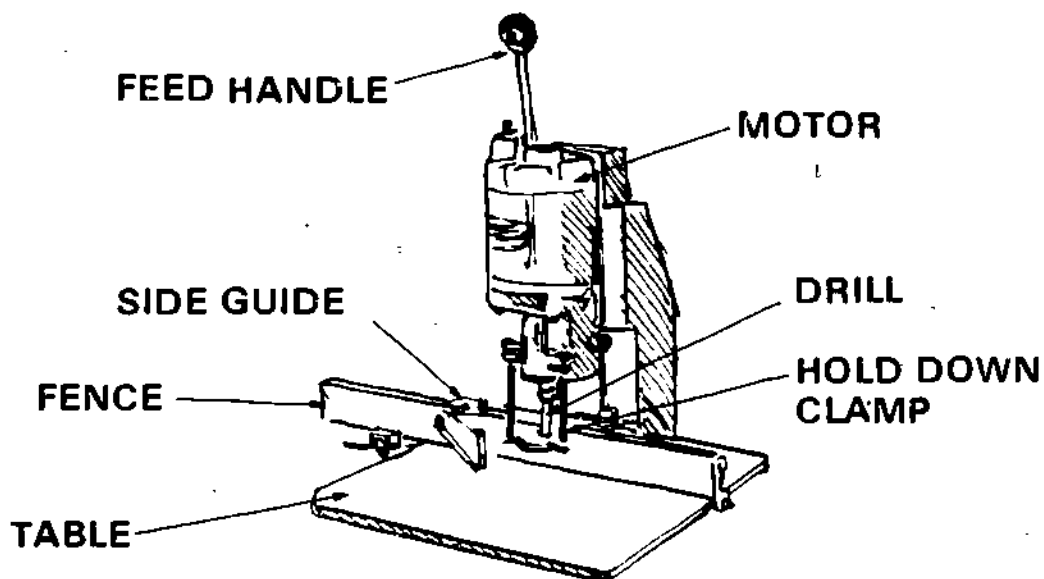

12.50

S _____

Name _____

Class _____

Date _____ Grade _____

Safety Quiz

(Circle True or False)

- 1. Guides or positive stops can be adjusted while the drill running. T F
- 2. When drilling paper the drill bit does not get hot. T F
- 3. Only one person should operate the unit at one time. T F
- 4. Hands must be kept clear of the hold down and drilling area. T F

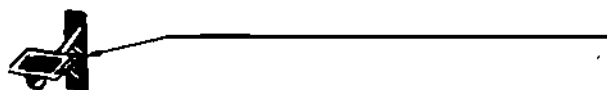
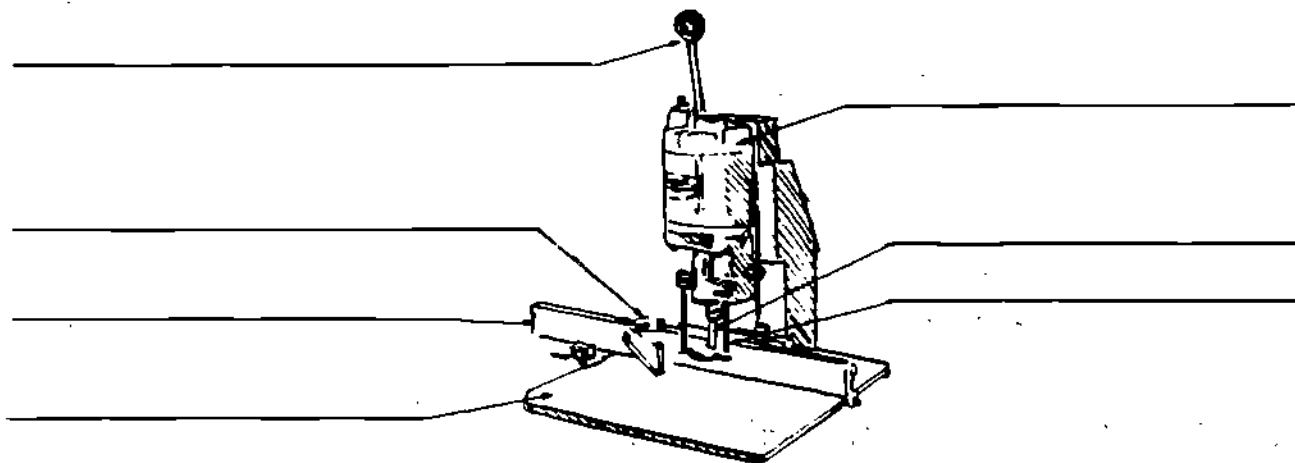

(Print the correct names)

12.51

For Safety —

1. Operate only with instructors permission and after you have received instruction.
2. Remove jewelry, eliminate loose clothing, and confine long hair.
3. Make sure all guards are in place and operating correctly.
4. Always use proper eye protection.
5. Be sure to check all material for loose knots, nails and other foreign objects.
6. Do not force stock through the planer. Keep hands off the material & let the power feed operate.
7. Select the proper depth of cut and the rate of speed depending on the stock being planed.
8. Thin stock should be properly supported by a jig or back up board. Check with the instructor for minimum thickness and length.
9. Never look directly into the throat of a planer at table level while it is running or in operation.
10. Remove shavings or chips when the power is turned off. Keep hands away from chip guard and the point of operation.
11. Do not stand directly in front of the machine in line of possible kick back.

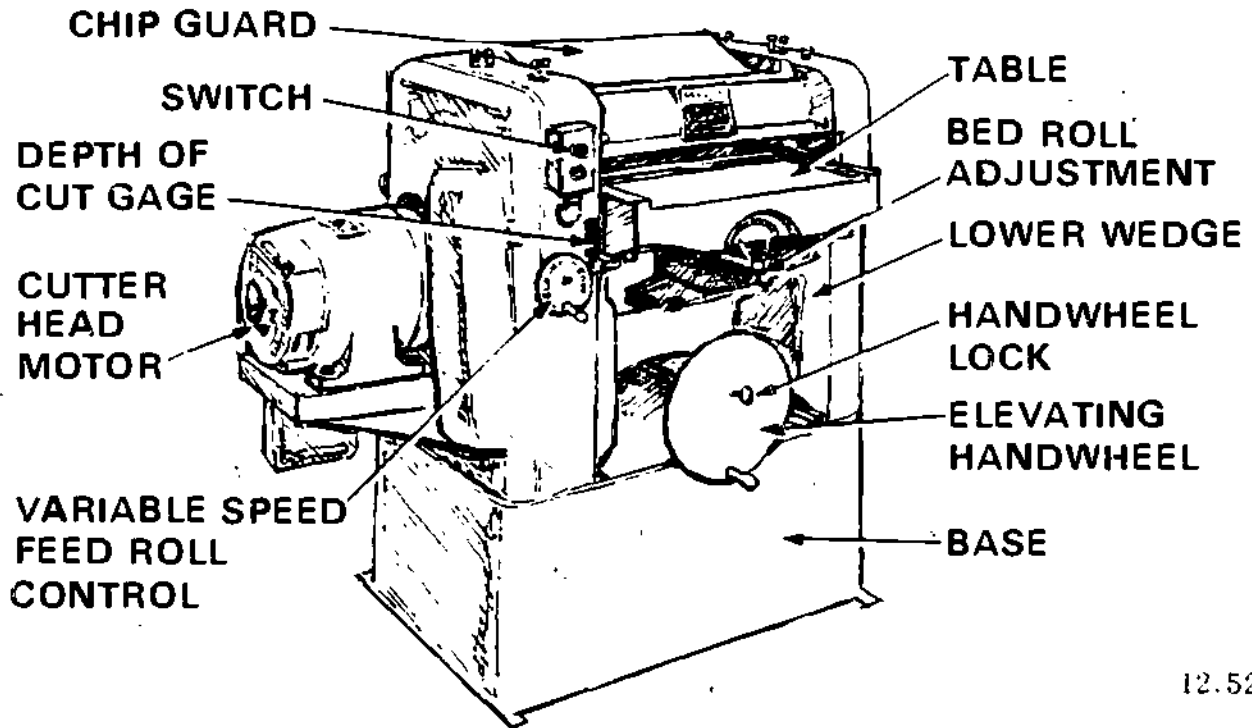

12.52

S _____

Name _____

Class _____

Date _____ Grade _____

Safety Quiz

(Circle True or False)

1. There is no real minimum regarding thickness or length of stock which can be planed safely. T F
2. Stock should be pulled through the planer by hand. T F
3. You should never look into the throat area at table level. T F
4. The power should be turned off while removing chips or shavings. T F
5. A jig or other support is often needed for thin stock. T F
6. The proper depth of cut and rate of speed is related to the material being planed. T F

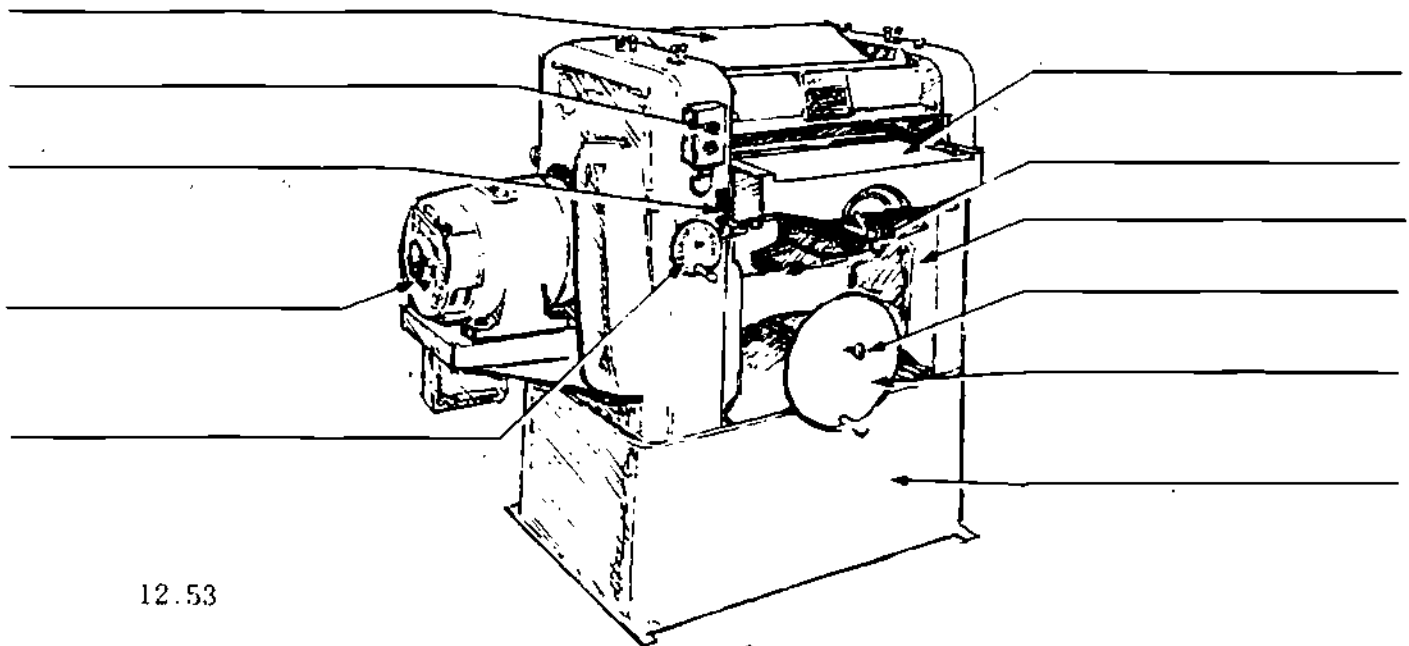

12.53

(Print the correct names)

For Safety —

1. Operate only with instructors permission and after you have received instruction.
2. Remove jewelry, eliminate loose clothing, and confine long hair.
3. Make sure all guards are in place and operating correctly.
4. Always use proper eye protection.
5. All three of these machines operates with heating units — use with caution.
6. Do not over heat — match heat/timecycle with material being used.
7. Observe and stay clear of pinch points.
8. Do not over pressure Injection Molder Ran.

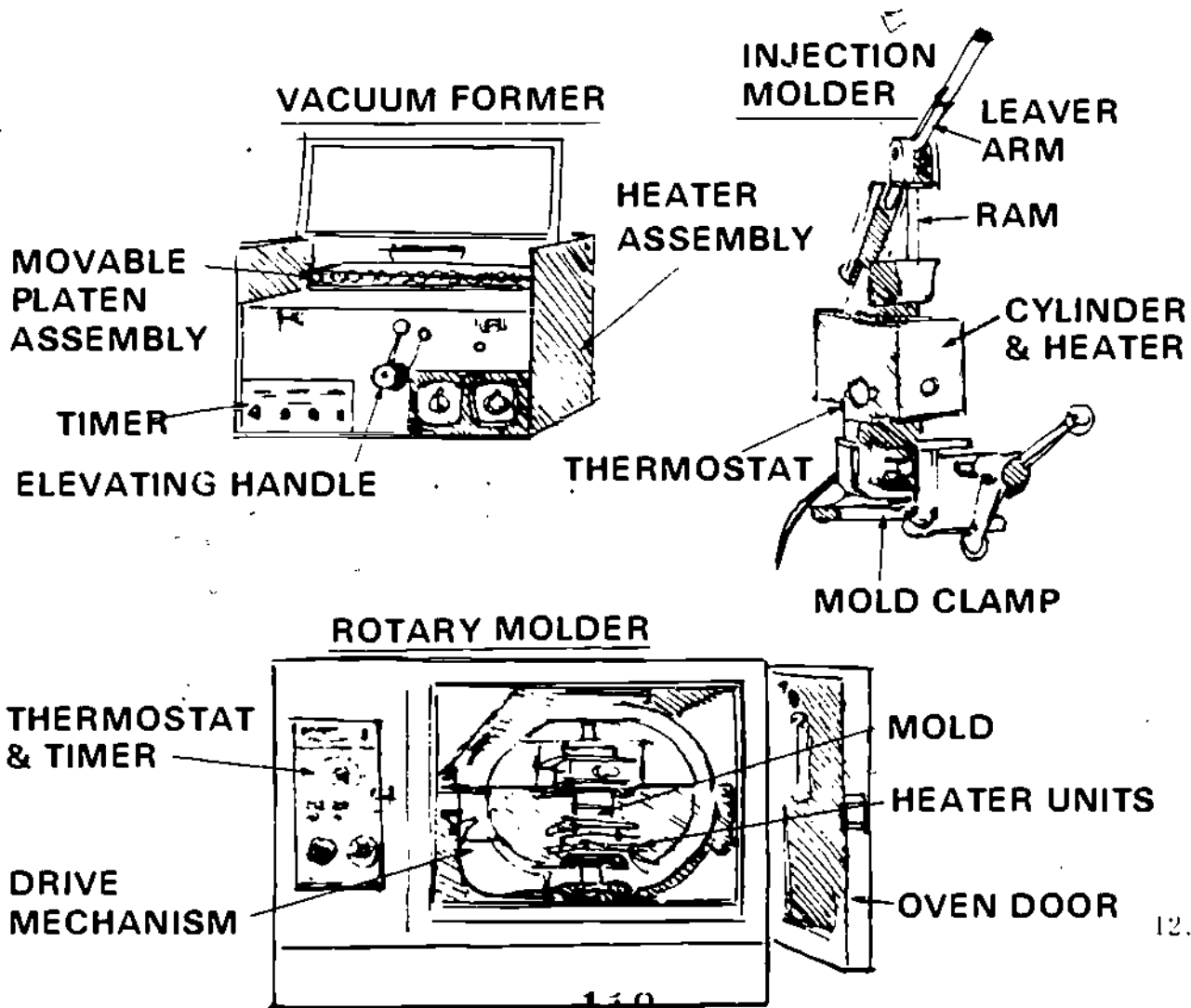

12.54

S _____

Name _____

Class _____

Date _____ Grade _____

Safety Quiz

(Circle True or False)

- 1. The injection molder can not be over pressurized. T F
- 2. The heat and time cycle should be matched with the type of material. T F
- 3. There are no pinch points on this type of equipment. T F
- 4. The work piece is usually too hot to touch with bare hands when formed or completed. T F

VACUUM FORMER

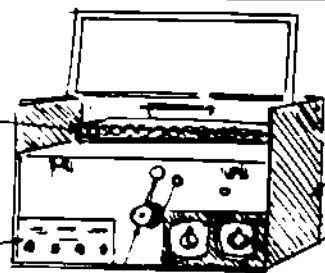

INJECTION MOLDER

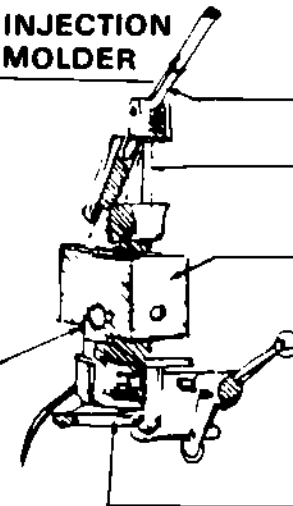

ROTARY MOLDER

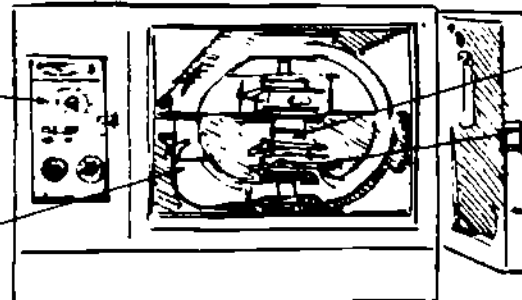

(Print the correct names)

12.55

For Safety —

1. Operate only with instructors permission and after you have received instruction.
2. Remove jewelry, eliminate loose clothing, and confine long hair.
3. Make sure all guards are in place and operating correctly.
4. Always use proper eye protection.
5. Operate the press at a speed that matches your ability to feed the paper
6. Apply ink to the ink plate prior to starting the press.
7. Make sure the grippers are not in the way of the type form.
8. Only one operator at the press at a time.
9. Keep your hands out of the press when creating an impression

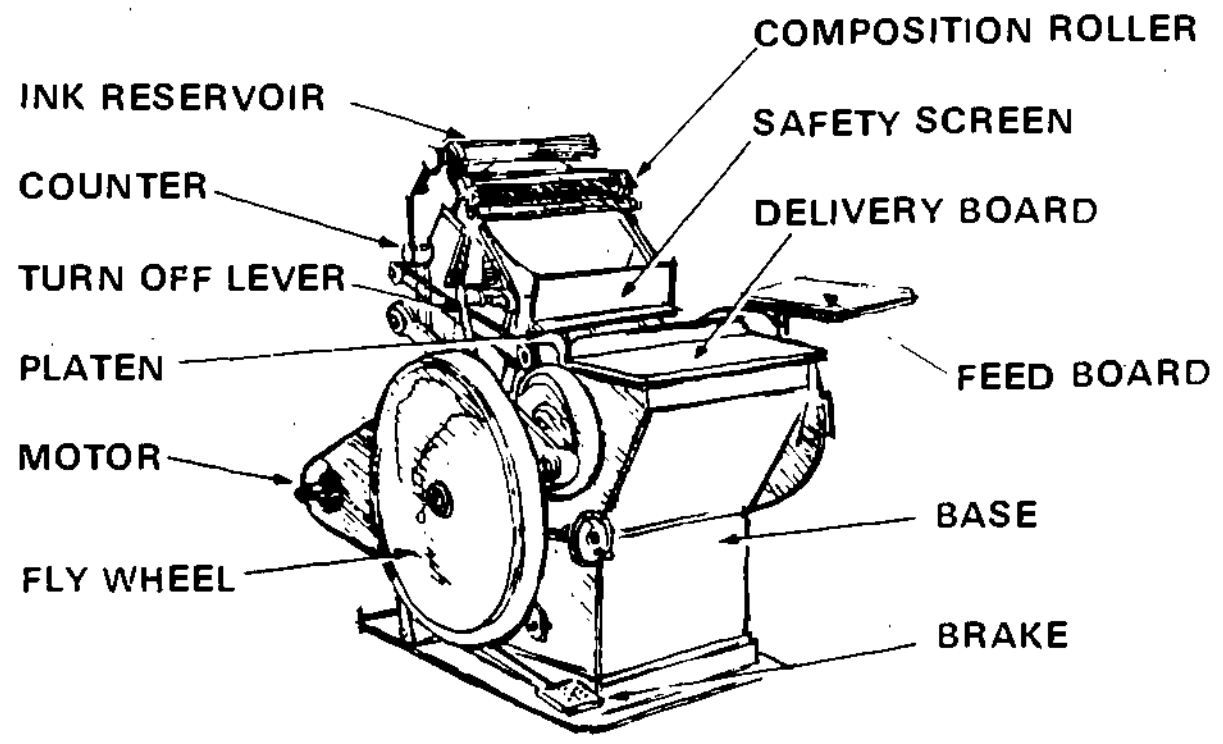

Platen Printing Press

S _____

Name _____

Class _____

Date _____ Grade _____

Safety Quiz

(Circle True or False)

1. Operate the press at a speed that is safe for your ability level. T F
2. Loose clothing or hair must be confined. T F
3. The position of the grippers is not important. T F
4. The ink plate may be inked while the press is in operation. T F
5. Three or four people can successfully operate the platen press at the same time. T F

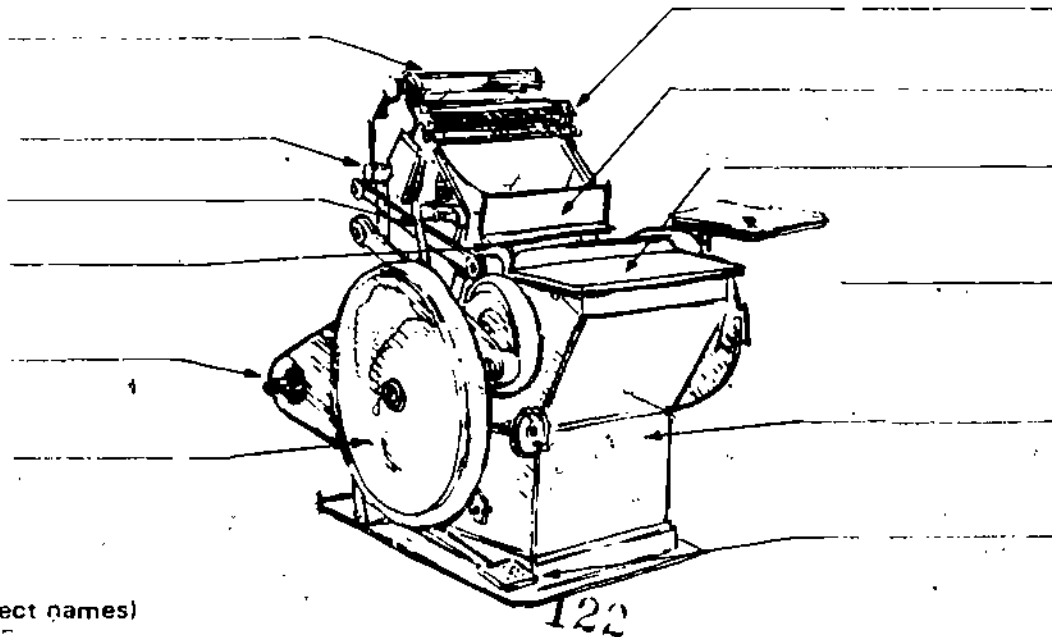

(Print the correct names)
12.57

For Safety —

1. Operate only with instructor's permission and after you have received instruction.
2. Remove jewelry, eliminate loose clothing, and confine long hair.
3. Make sure all guards are in place and operating correctly.
4. Always use proper eye protection.
5. Make all adjustments with the power off.
6. Be sure the leaf guards are operating properly and the blade will not extend beyond the table edge.
7. When cross cutting hold the material securely against the fence.
8. Always pull the blade through the work and return the cutter head behind the fence before removing material or starting the next cut.
9. Make sure the blade guard and kickback fingers are properly adjusted before ripping.
10. Always rip into the blade, never in the same direction as the rotation.
11. Make sure the blade has stopped before leaving the machine.

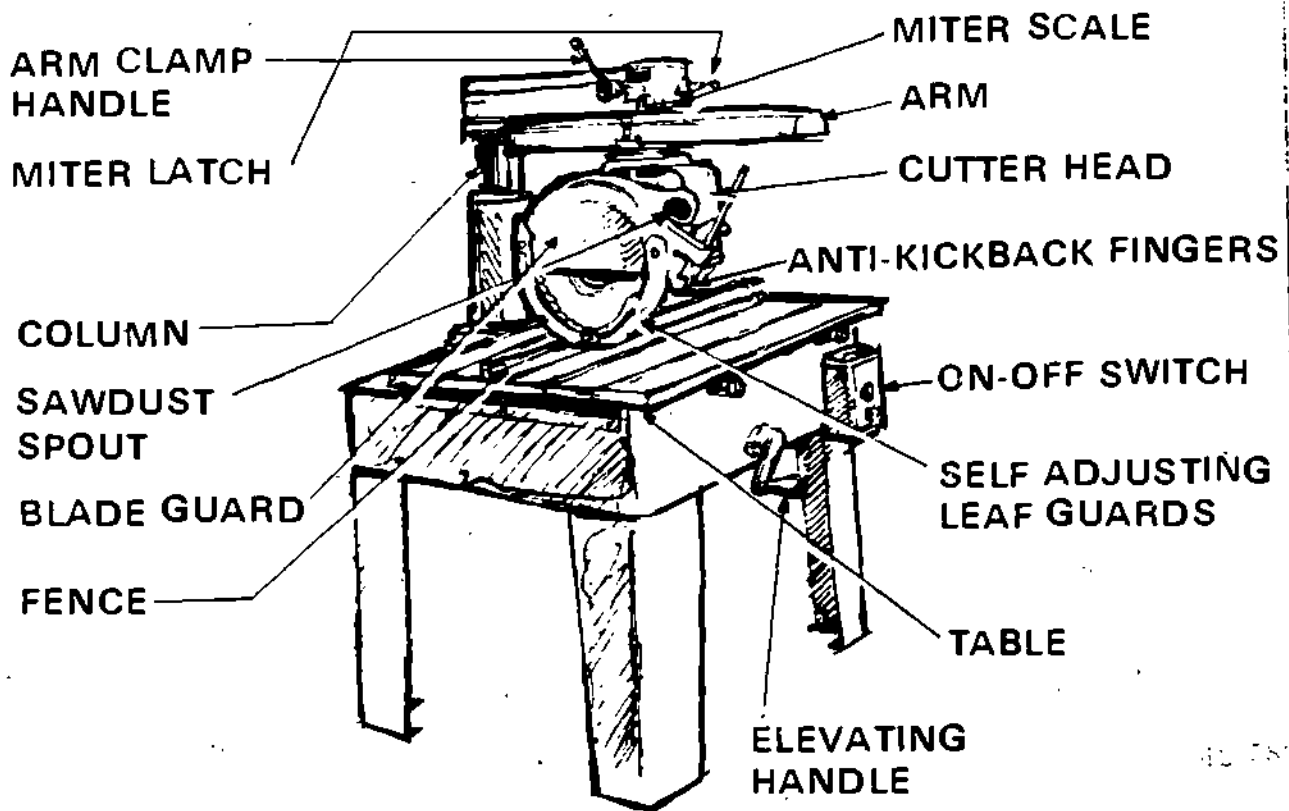

S _____

Name _____

Class _____

Date _____ Grade _____

Safety Quiz

(Circle True or False)

1. Eye protection is not necessary except when ripping. T F
2. The guard and kickback fingers must be in place when ripping. T F
3. The saw blade may safely extend beyond the table. T F
4. The blade should be installed so that in cross cut position the teeth at the bottom of the blade point away from the operator. T F
5. When ripping, one hand must hold the material and the other hand operate the saw. T F
6. In cross cutting, the saw should be returned to the rear of the arm upon the completion of each cut. T F

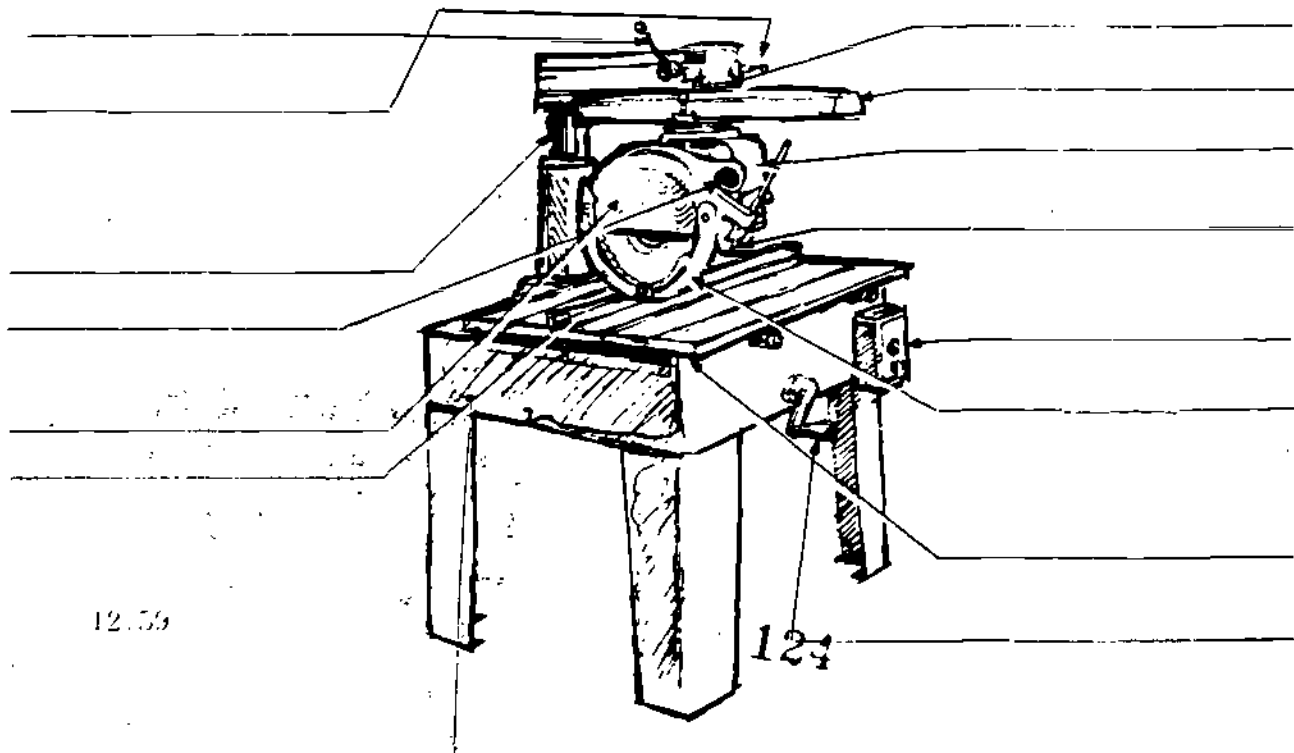

12.59

124

For Safety —

1. Operate only with instructors permission and after you have received instruction.
2. Remove jewelry, eliminate loose clothing, and confine long hair.
3. Make sure all guards are in place and operating correctly.
4. Always use proper eye protection.
5. Make all adjustments with the power off, then rotate the motor by hand as a final check.
6. Be sure hold down is pressing lightly on the work piece.
7. The blade should be held firmly in the chucks, be square with the table, and be properly supported by the guide assembly.
8. Guide the material slowly through the machine with both hands, keeping fingers away from the cut line.
9. Choose the correct blade and correct speed for the material to be cut, and for the smallest radius required.

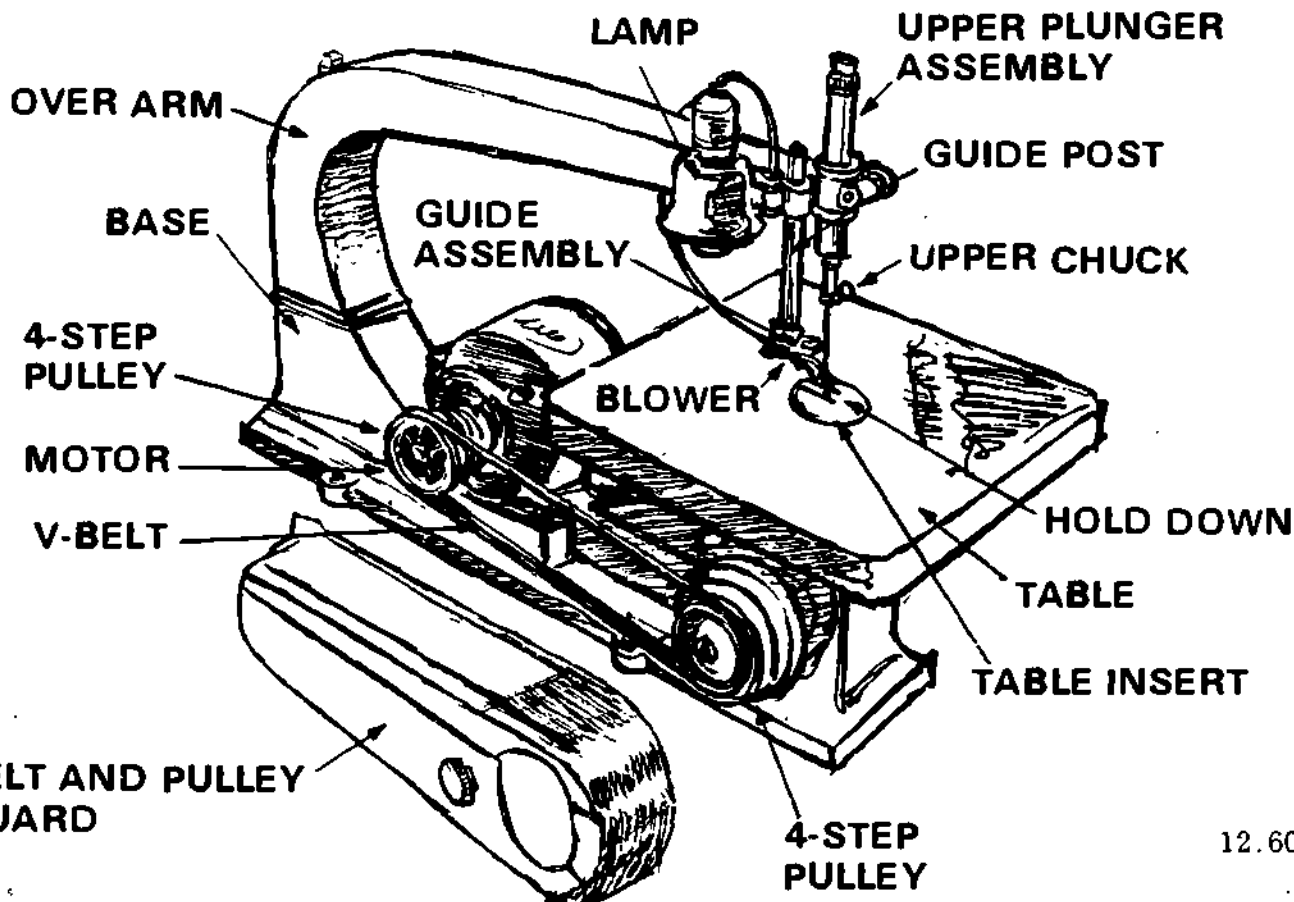

12.60

S _____

Name _____

Class _____

Date _____ Grade _____

Safety Quiz

(Circle True or False)

1. If the blade pinches in the kerf you should just push harder. T F
2. It is necessary to have the flat side of the stock tight against the table. T F
3. Fingers should be kept away from the cutting line. T F
4. The hold down should be 1/16" from the work piece. T F
5. After changing blades or making guide adjustments the machine should be rotated one full stroke by hand. T F

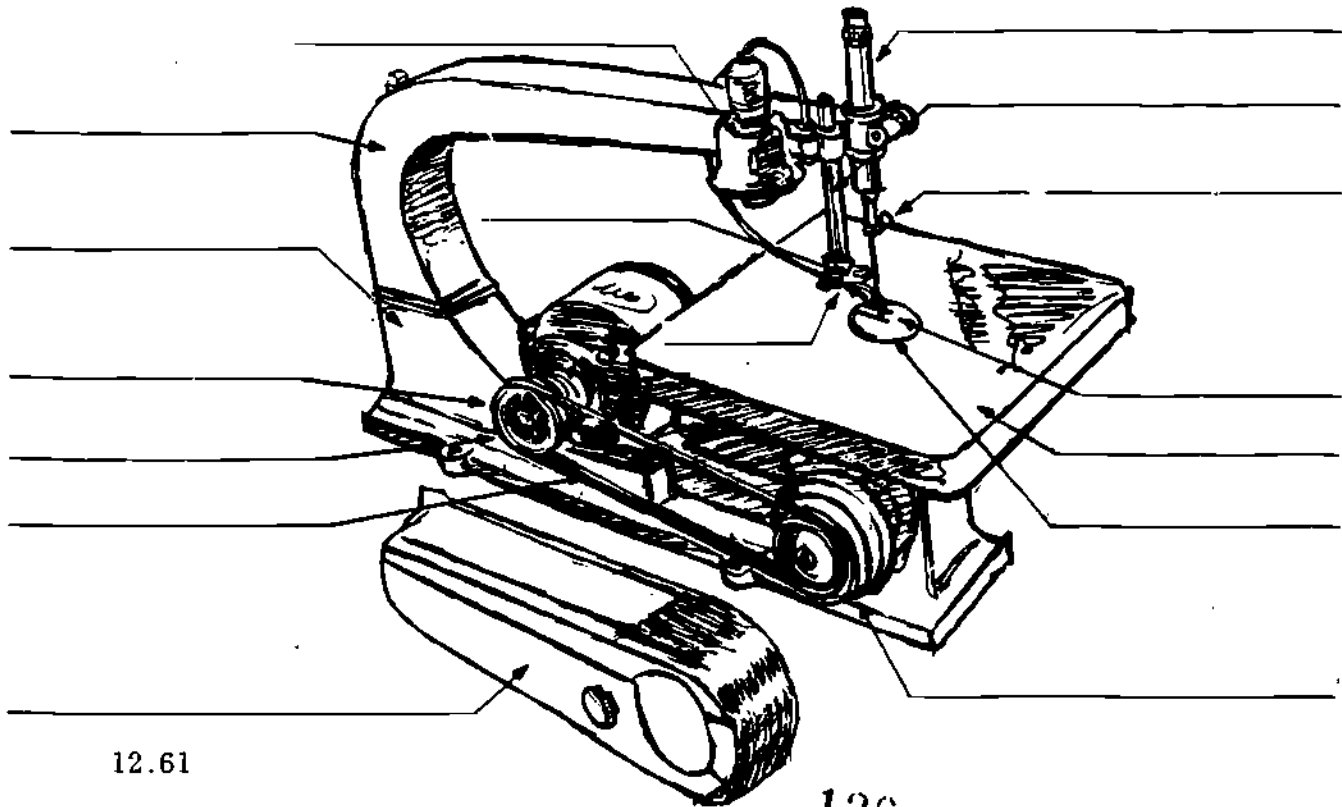

12.61

126

For Safety —

1. Operate only with instructors permission and after you have received instruction.
2. Remove jewelry, eliminate loose clothing, and confine long hair.
3. Make sure all guards are in place and operating correctly.
4. Always use proper eye protection.
5. Adjust, change rolls, set stops, and properly check or assemble before operating.
6. Never bend, roll, crimp or bead metal which exceeds the capacity of the machine.
7. Work with only one piece of metal at one time, never double thickness or two pieces side by side.
8. Remove burrs from the metal before attempting to work it in the machine.
9. Keep hands away from clamps, jaws, rolls and other pinch points.
10. Do not force hit or drop-levers or handles.

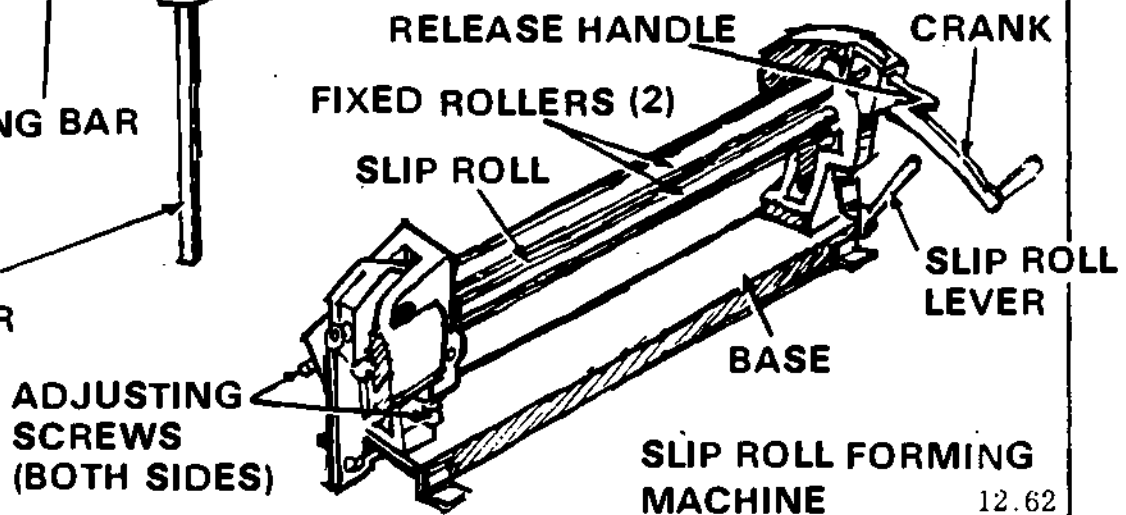
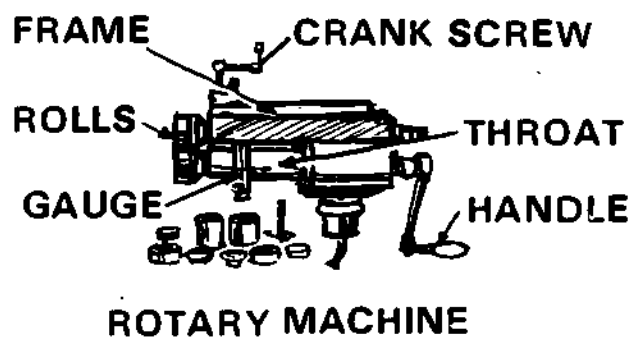
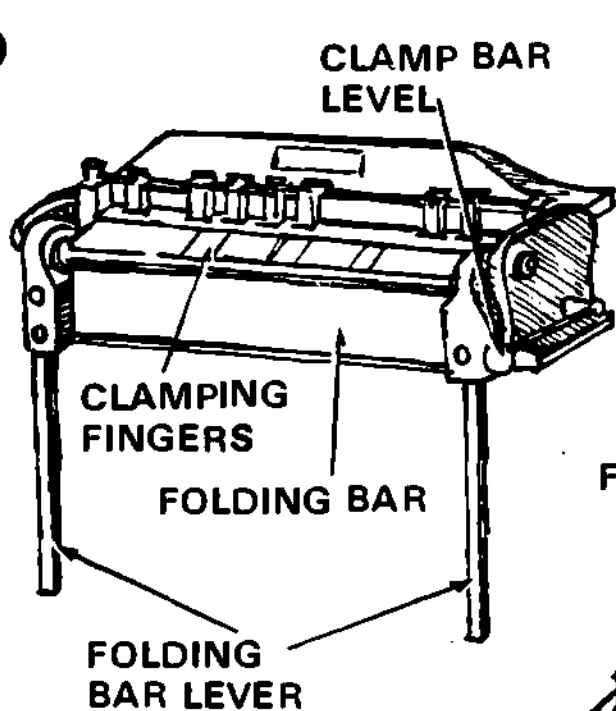

Sheet Metal Machines

S _____

Name _____

Class _____

Date _____ Grade _____

Safety Quiz

(Circle True or False)

1. The infeed rolls of a roll machine are dangerous to the operator's hands. T F
2. Sheet metal machines can be damaged by overloading. T F
3. Sharp burrs and edges should be removed before attempting to place in the machine. T F
4. Fingers must be kept clear of moving parts. T F
5. Quarter inch mild steel stock can be formed on the sheet metal machine. T F
6. If a handle jams it can be tapped lightly with a hammer. T F

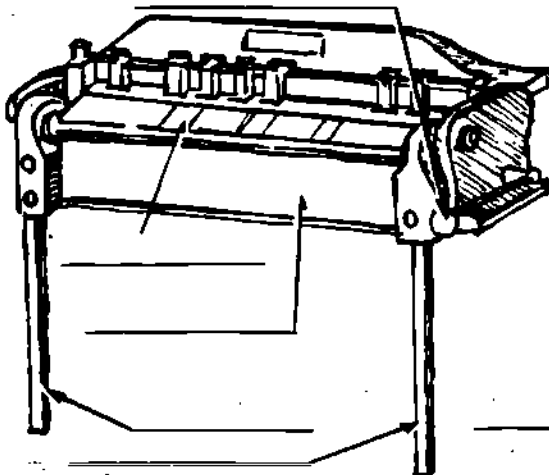
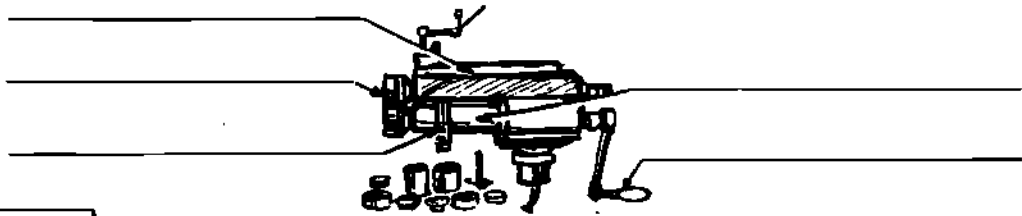

12.63

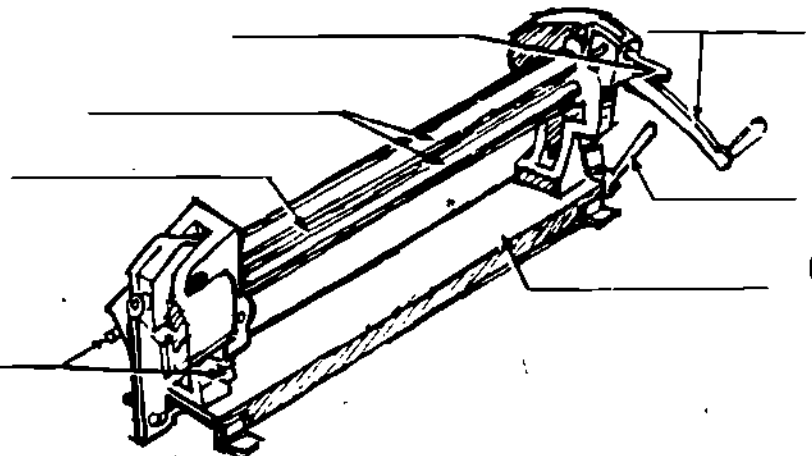

128

For Safety —

1. Operate only with instructors permission and after you have received instruction.
2. Remove jewelry, eliminate loose clothing, and confine long hair.
3. Make sure all guards are in place and operating correctly.
4. Always use proper eye protection.
5. Utilize unit only with proper exhaust ventilation system.
6. Exercise caution when handling fuel, filling fuel tank, wipe up all spillage. Inspect fuel system frequently for defects.
8. Make sure all engines have proper lubrication and are mounted securely.
9. Utilize caution while operating and after operation, because engine will be hot.

INSTRUMENT PANAL
MERCURY COLUMN TORQUE GAGE
FUEL FLOW ROTAMETER
INCLINED MANOMETER
ELECTRICAL TACHOMETER
DYNOMETER LOAD CENTER

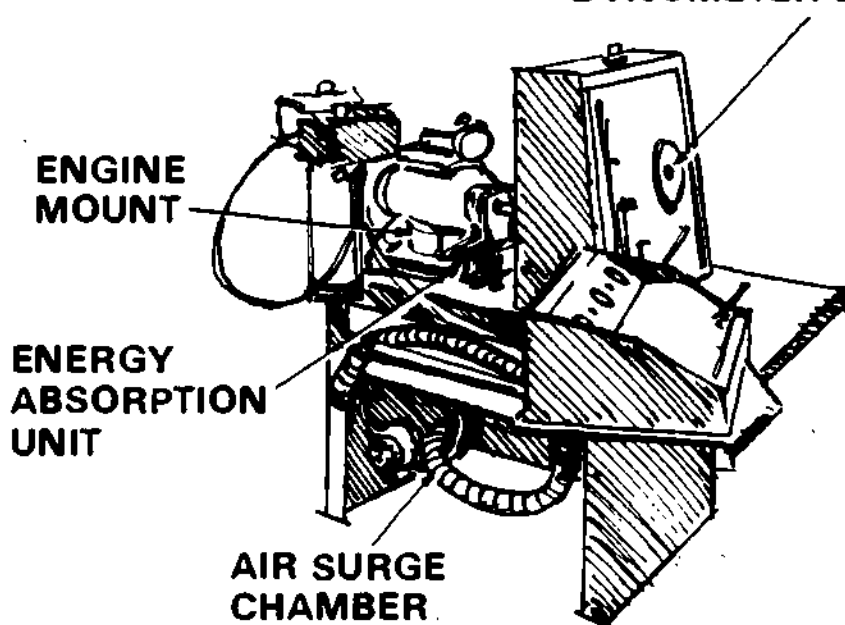

S _____

Name _____

Class _____

Date _____ Grade _____

Safety Quiz

(Circle True or False)

1. After testing the engine is usually too hot to touch. T F
2. The oil level in the engine should be checked before testing. T F
3. Since the engine runs only a short time exhaust ventilation is not critical. T F
4. Small amounts of spilled fuel are not really hazardous. T F
5. The engine must be mounted securely. T F

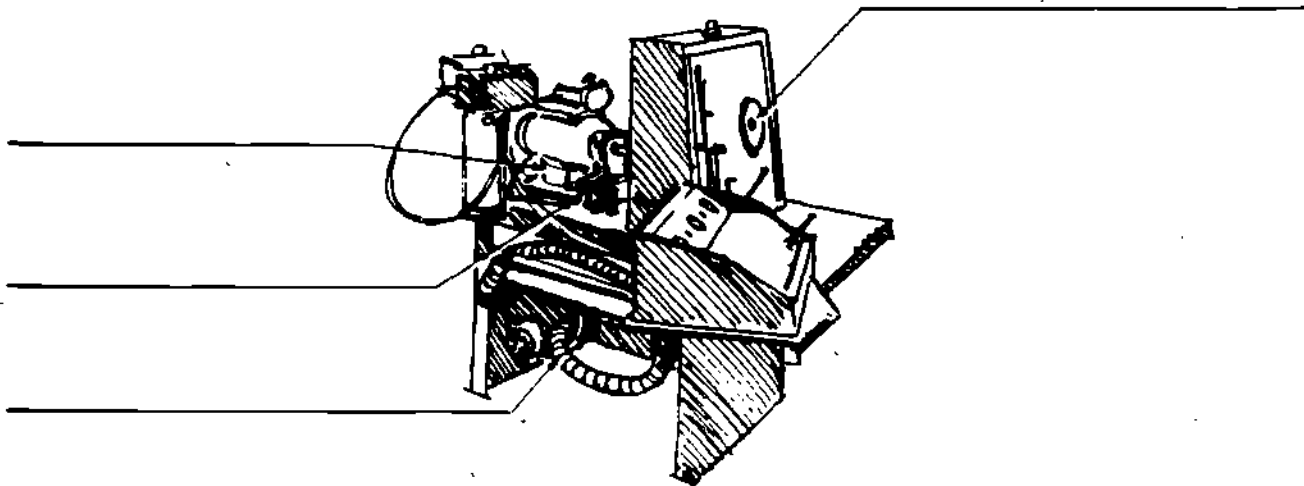

(Print the correct names)

12.65

130

For Safety —

1. Operate only with instructors permission and after you have received instruction.
2. Remove jewelry, eliminate loose clothing, and confine long hair.
3. Make sure all guards are in place and operating correctly.
4. Always use proper eye protection.
5. Be sure and stand clear of the spindle nose in front of the spinning lathe.
6. Do not touch a spinning disc with your hand.
7. The tool rest should be no farther than 1" away from the disc.
8. Tool rest base, tool rest and fulcrum pin must be tight and secure.
9. Use the correct tool for the operation and slowly force material to match the forming chuck.
10. Remove tool rest and pin when using steel wool or polishing.

FORMING CHUCK

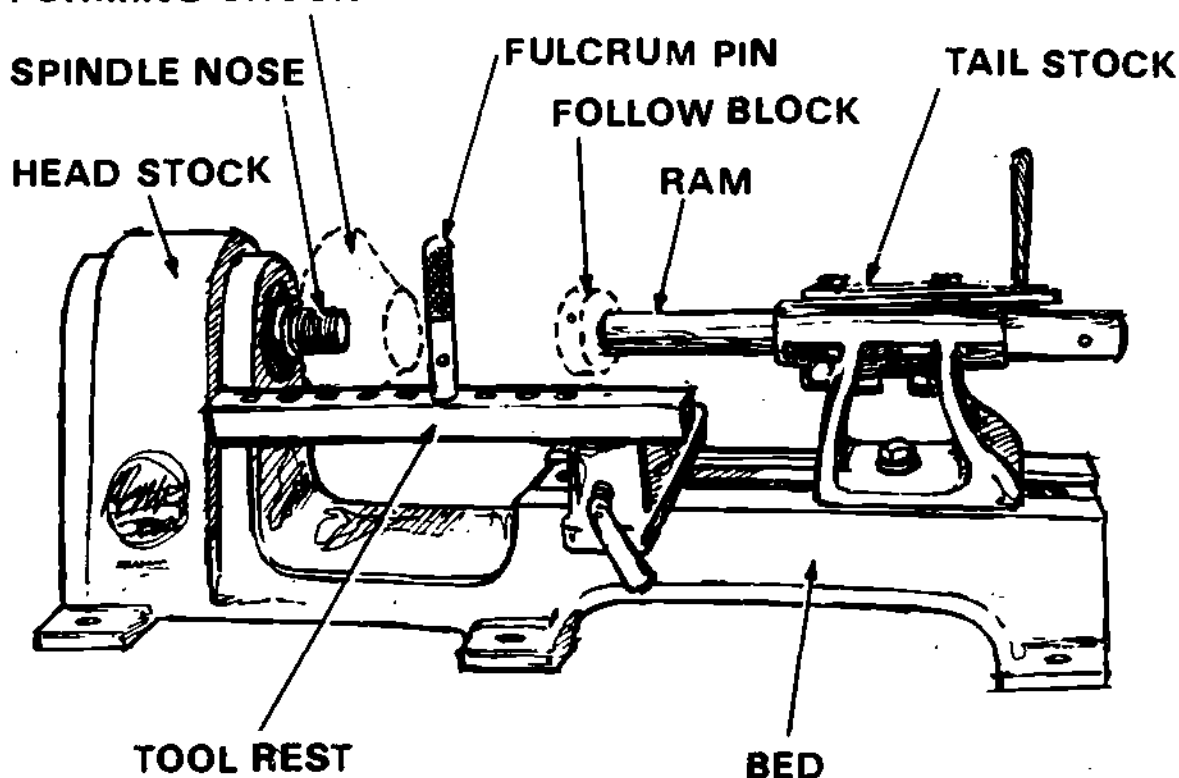

12.66

S _____

Name _____

Class _____

Date _____ Grade _____

Safety Quiz

(Circle True or False)

1. There is really no danger zone in front of a spinning lathe. **T** **F**
2. The spinning disc or material should never be touched with the hands. **T** **F**
3. 2" is the correct working distance between the tool rest and the disc. **T** **F**
4. Eye safety protection is not necessary when spinning since there are no chips. **T** **F**
5. There is a correct tool for each of the various spinning operations. **T** **F**

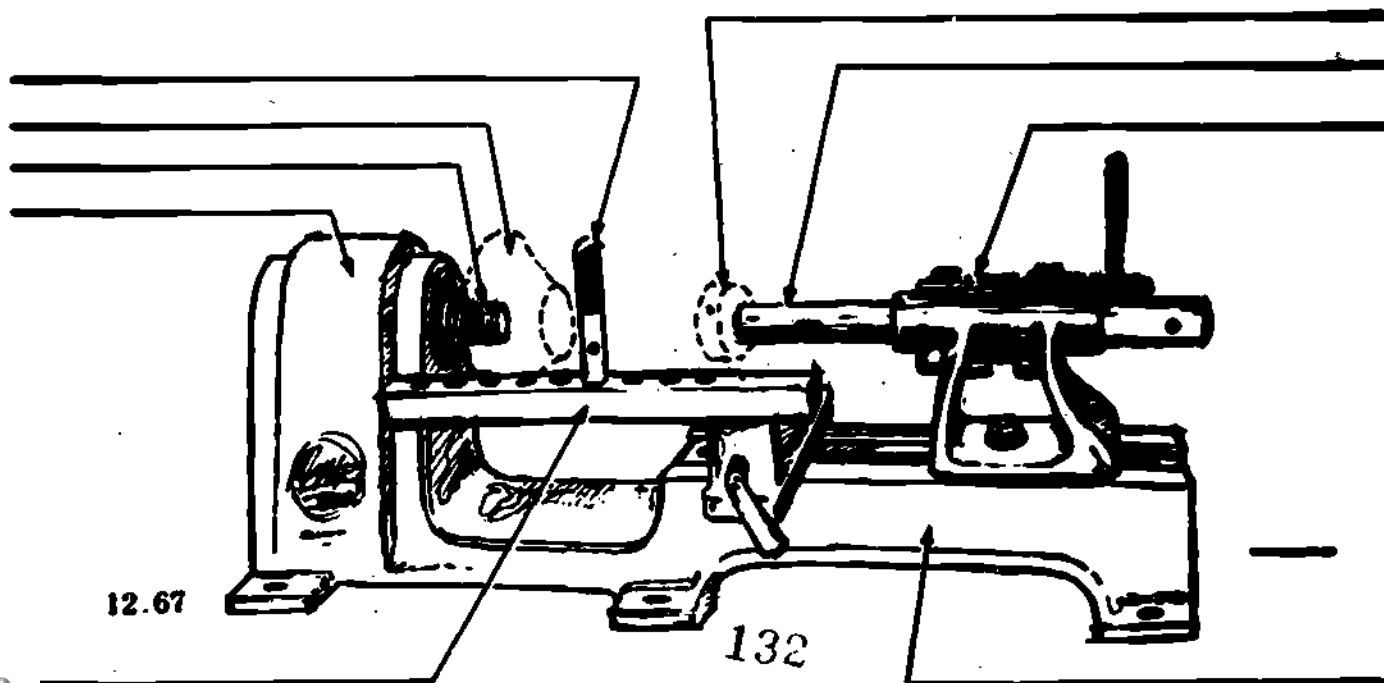

12.67

132

For Safety —

1. Operate only with instructor's permission and after you have received instruction.
2. Remove jewelry, eliminate loose clothing, and confine long hair.
3. Make sure all guards are in place and operating correctly.
4. Always use proper eye protection.
5. Check the machine and the setup before operating. If needed, get a helper.
6. Never exceed the capacity of the machine.
7. Use gloves when handling large pieces of sheet metal, and remove obvious burrs from all pieces.
8. Keep fingers at least 3" away from pressure bar—hold down-guard—and blade.
9. Do not attempt to catch small pieces, allow them to fall to the floor.
10. Operate only from the front of the machine.
11. Keep area under and around the machine clean and feet out from under the foot pedal.

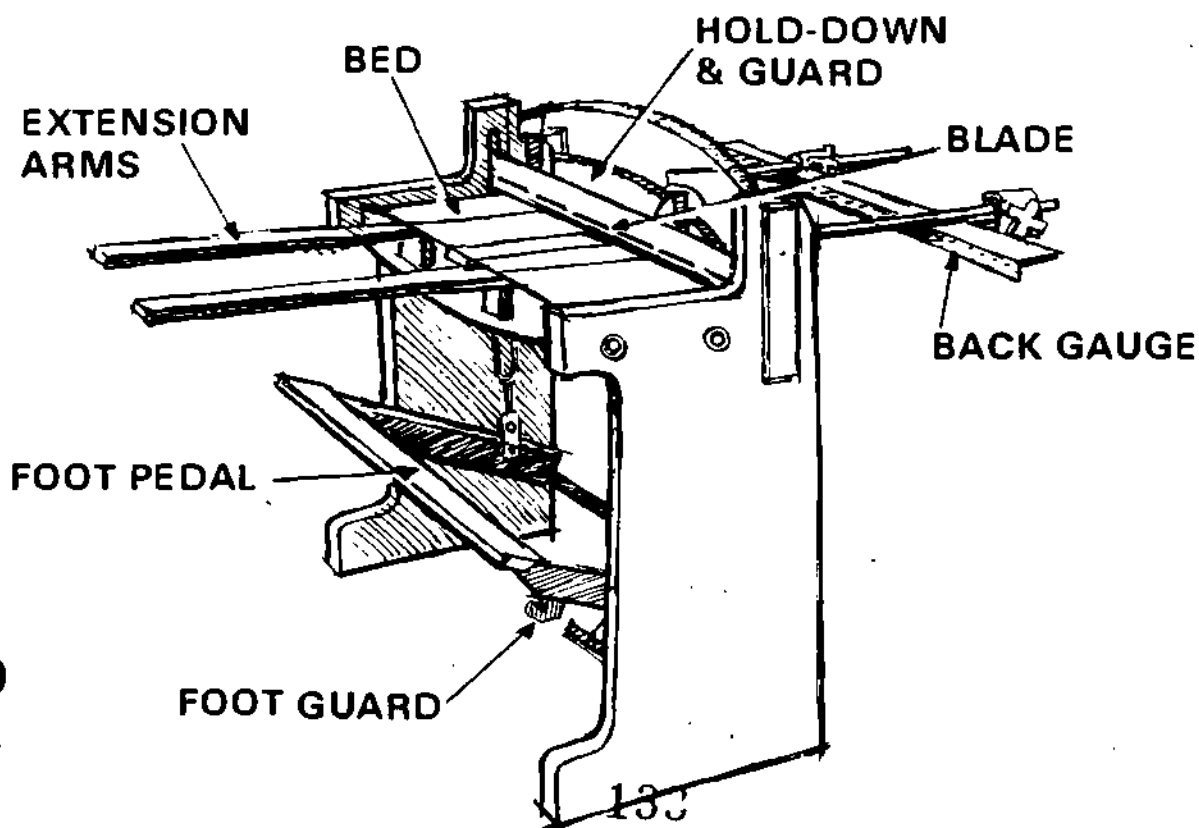

Squaring Shears

S _____

Name _____

Class _____

Date _____ Grade _____

Safety Quiz

(Circle True or False)

1. Feed and operate from the treadle side of the machine only. T F
2. It is permissible to let small pieces drop into a box as they are cut. T F
3. Two students may operate the shear together. T F
4. For some projects the guard can be removed. T F
5. Gloves can be worn when operating this machine. T F
6. Eye protection is not required. T F

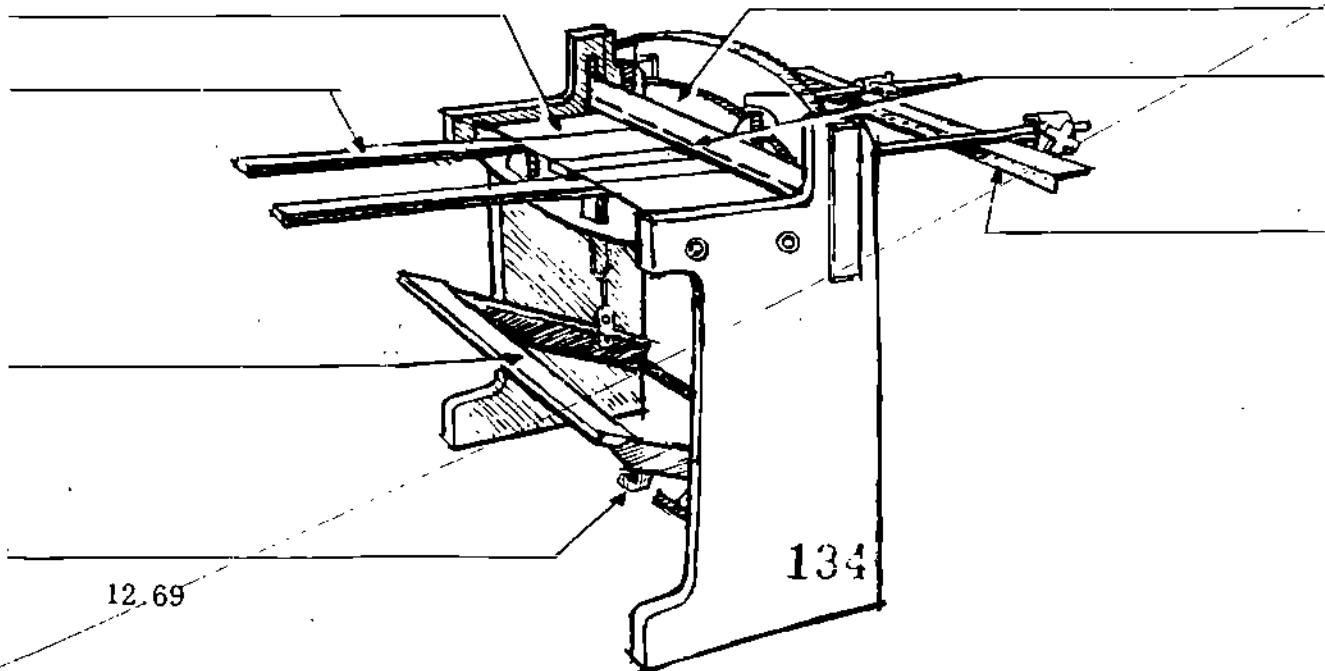

12.69

For Safety —

1. Operate only with instructors permission and after you have received instruction.
2. Remove jewelry, eliminate loose clothing, and confine long hair.
3. Make sure all guards are in place and operating correctly.
4. Always use proper eye protection.
5. Be sure power is disconnected on electric driven units when loading or making adjustments.
6. Keep hands clear of stapling or stitching are.
7. Do not exceed the capacity of the unit.
8. Be sure only one individual operates a unit.

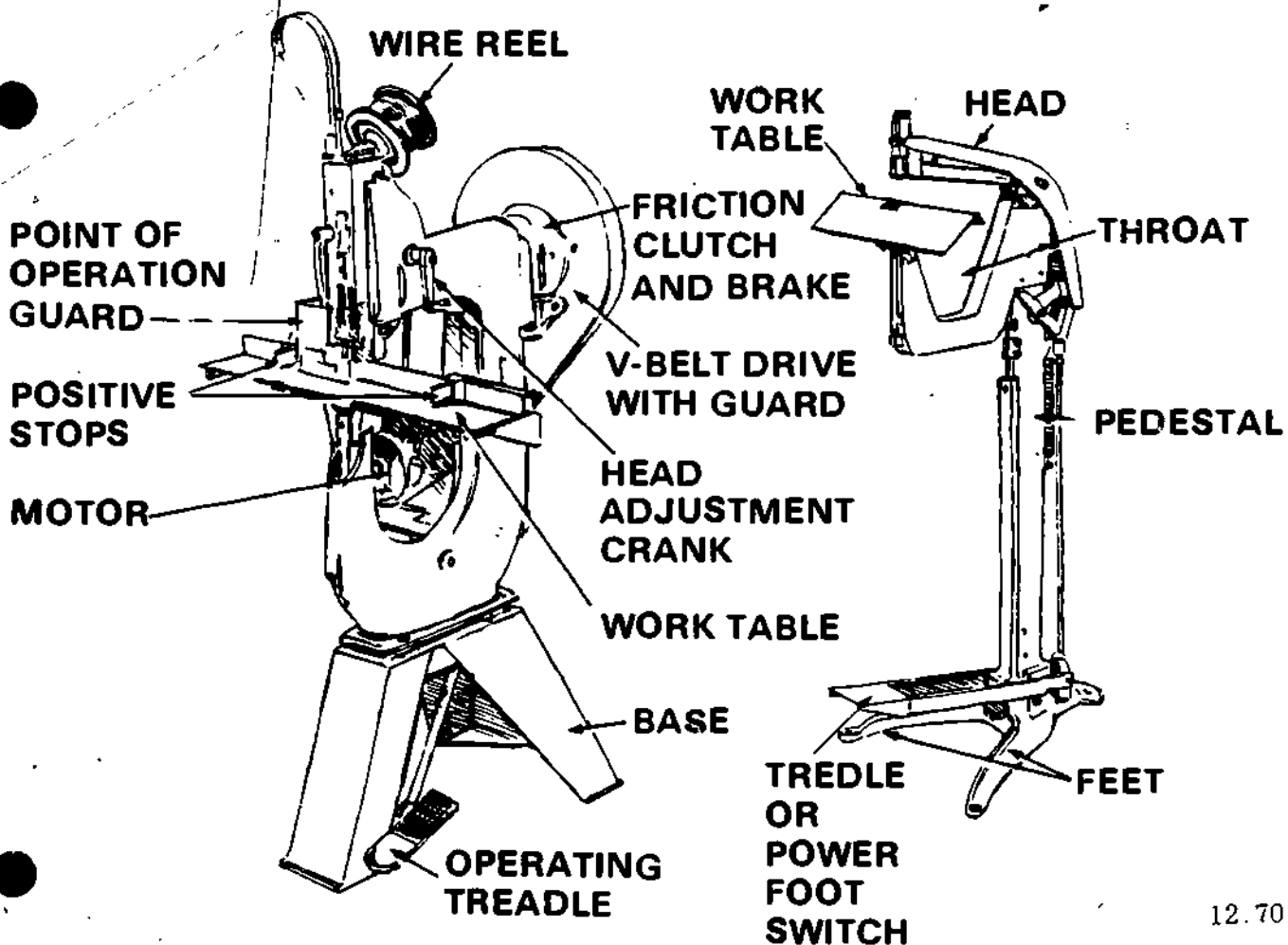

STICHER

STAPLER

12.70

S _____

Name _____

Class _____

Date _____ Grade _____

Safety Quiz

(Circle True or False)

1. Work of any thickness can be stapled or stitched. T F
2. Only one person should operate the unit at one time. T F
3. Minor adjustments can be made with the machine idling under power. T F
4. Hands must be kept clear of the stapeling or stitching area. T F

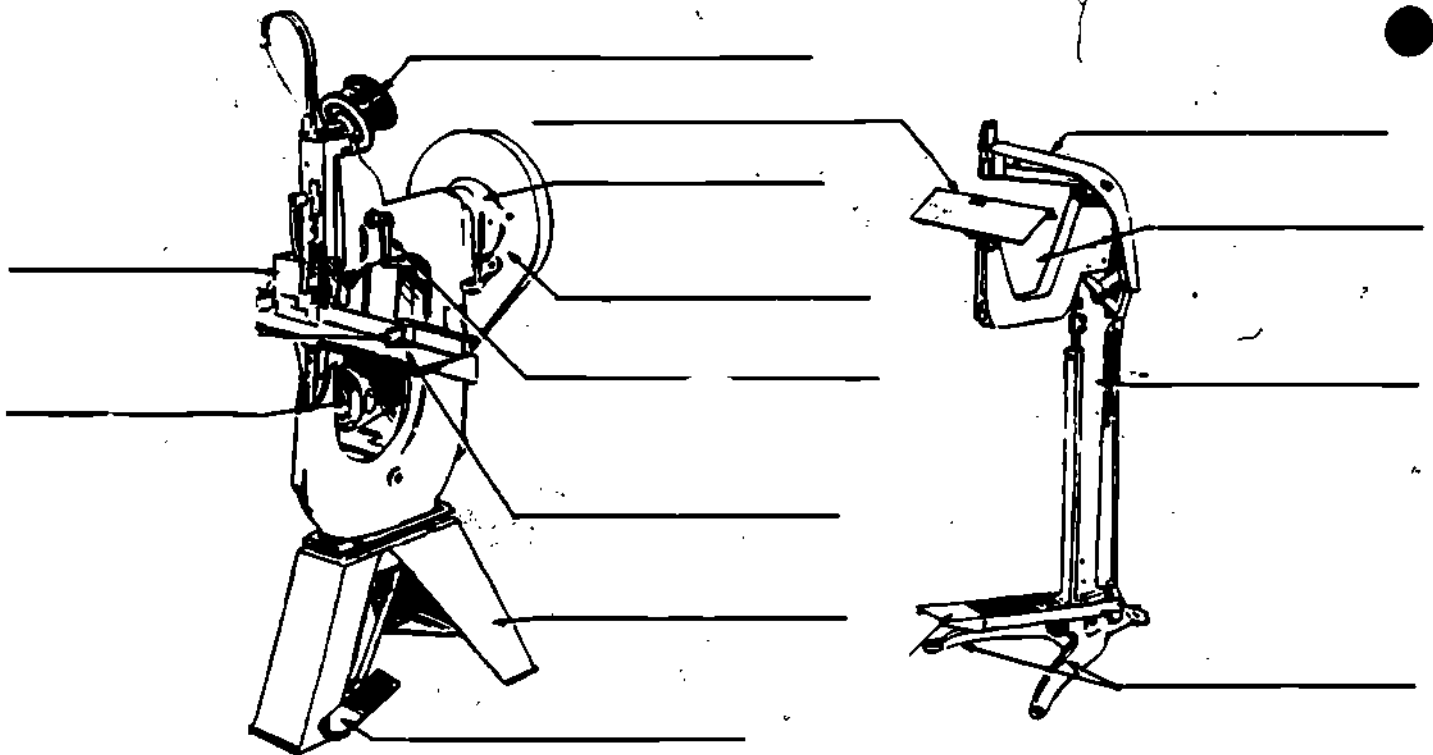

(Print the correct names)

12.71

For Safety —

1. Operate only with instructors permission and after you have received instruction.
2. Remove jewelry, eliminate loose clothing, and confine long hair.
3. Make sure all guards are in place and operating correctly.
4. Always use proper eye protection.
5. Additional protective welding clothing, including a helmet, long sleeve jacket, and gloves must be worn to prevent burns from ultraviolet and infra red rays emitted while arc welding.
6. The helmet used for TIG or MIG welding should be equipped with a minimum number twelve density shade.
7. Be certain that the welder equipped with a high frequency stabilizing unit is installed, maintained, and used according to the recommendations of both the manufacturer and the Federal Communication Commission.
8. Never touch the tungsten electrode or MIG wire while the welder is turned on. It is electrically "hot" and can cause a serious shock.
9. Never use the high frequency when performing shield metal arc (stick electrode) welding.

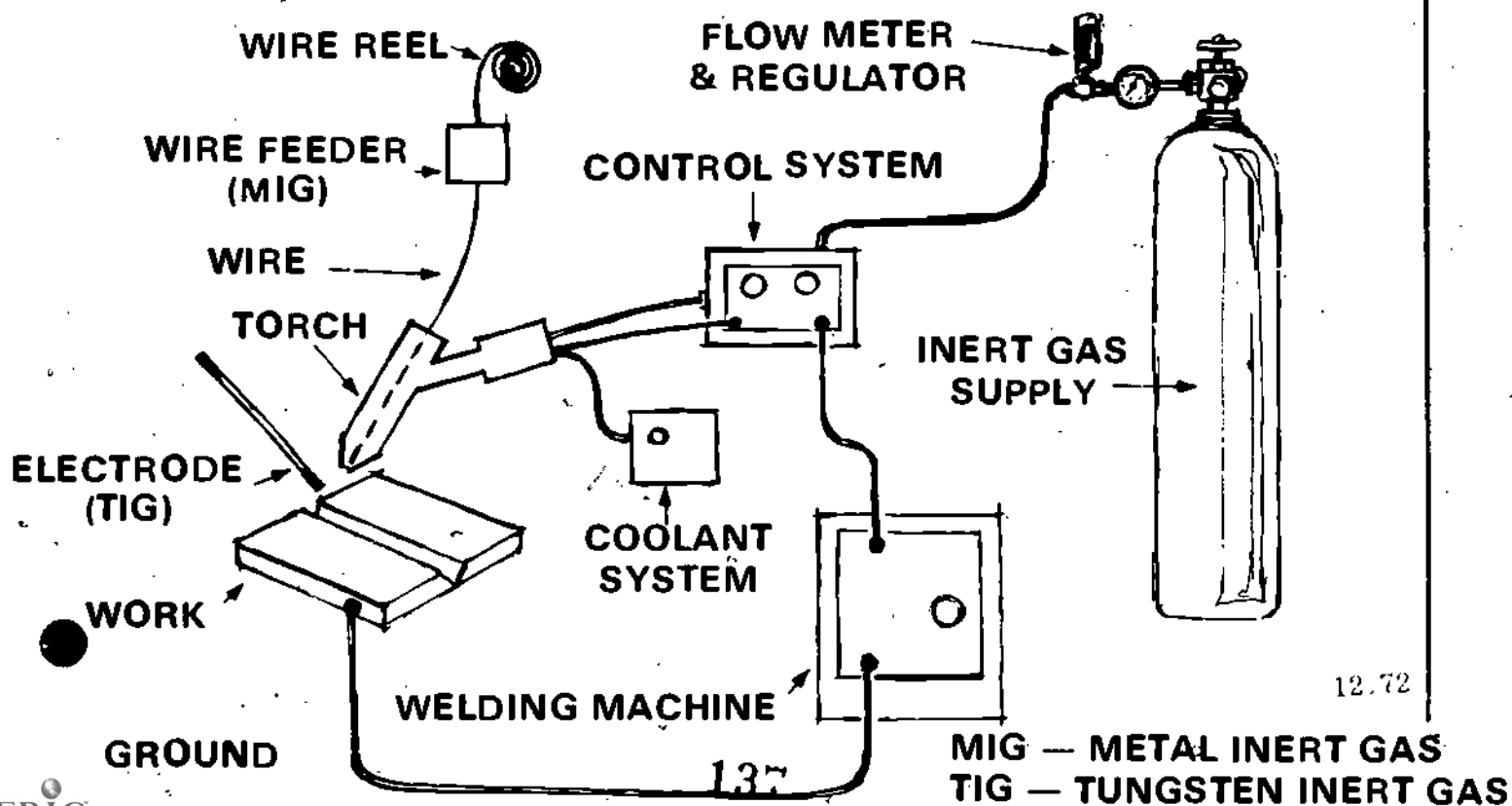

S _____

Name _____

Class _____

Date _____ Grade _____

Safety Quiz

(Circle True or False)

1. High frequency welding units are manufactured according to guidelines established by the Federal Communications Commission. T F

2. It is okay to do Tig or Mig welding without a welding helmet. T F

3. You can be shocked by touching the Tungsten electrode while the Tig welder is turned on. T F

4. The high frequency switch must be turned off while performing regular arc welding. T F

5. Both metal-arc welding and gas shielded arc welding, give off ultra violet and infrared radiation which can burn unprotected skin. T F

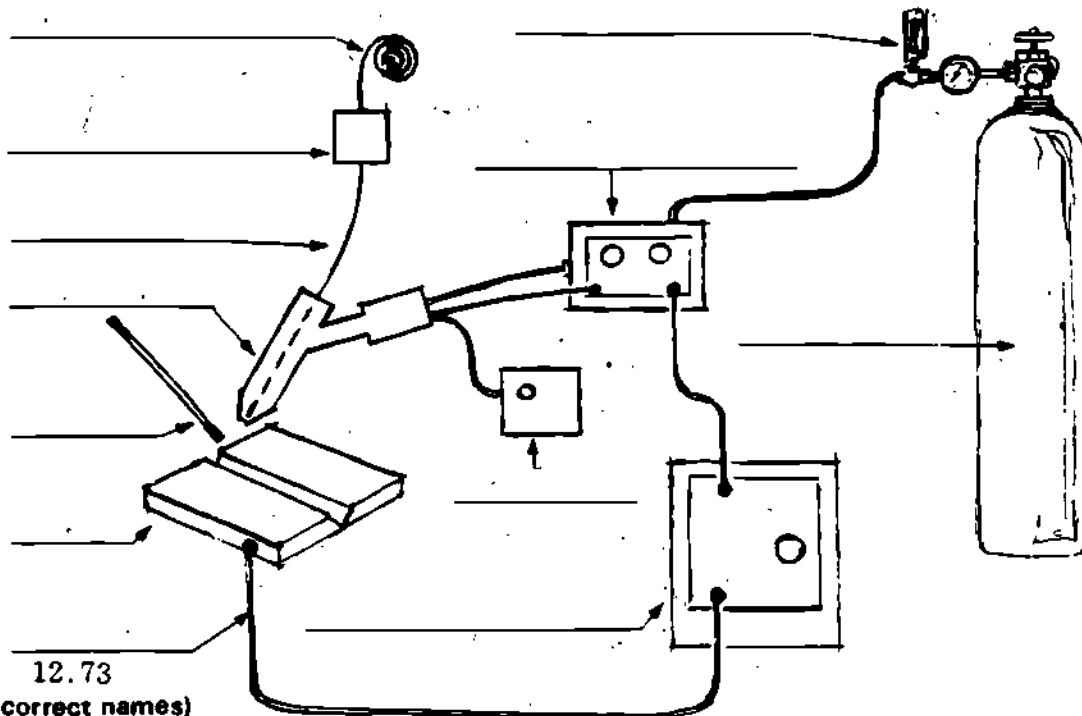

(Print the correct names)

For Safety —

1. Operate only with instructors permission and after you have received instruction.
2. Remove jewelry, eliminate loose clothing, and confine long hair.
3. Make sure all guards are in place and operating correctly.
4. Always use proper eye protection.
5. Be sure switch is in off position before adjusting depth of cut, table tilt, or checking cutters.
6. The guard must be clean and slide freely before beginning the operation. Do not clamp in the up position.
7. Always use push stick or a push block when planing small material.
8. Continue moving the work piece past the cutterhead until it is resting against the rear fence.
9. Do not brush chips or dust away from the point of operation until the machine has come to a full stop.

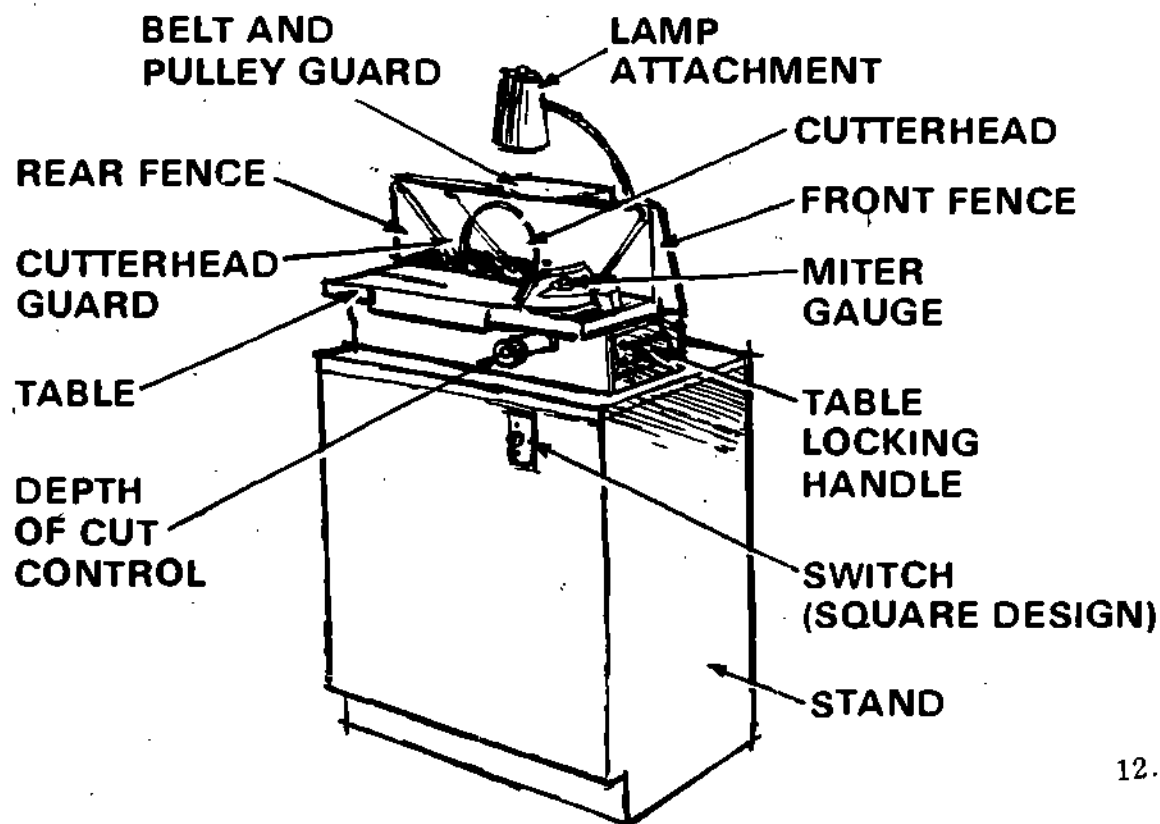

12.74

S _____

Name _____

Class _____

Date _____ Grade _____

Safety Quiz

(Circle True or False)

- | | | |
|--|---|---|
| 1. The guard should be clamped in position to clear the work piece. | T | F |
| 2. Loose cutters will give a rough cut but are not detrimental to safety. | T | F |
| 3. The work piece should be moved through the machine to the rear fence before removing. | T | F |
| 4. The machine must come to a full stop before it is safe to leave the work area. | T | F |
| 5. All adjustments should be made with the power off. | T | F |
| 6. A lamp attachment contributes to safety. | T | F |

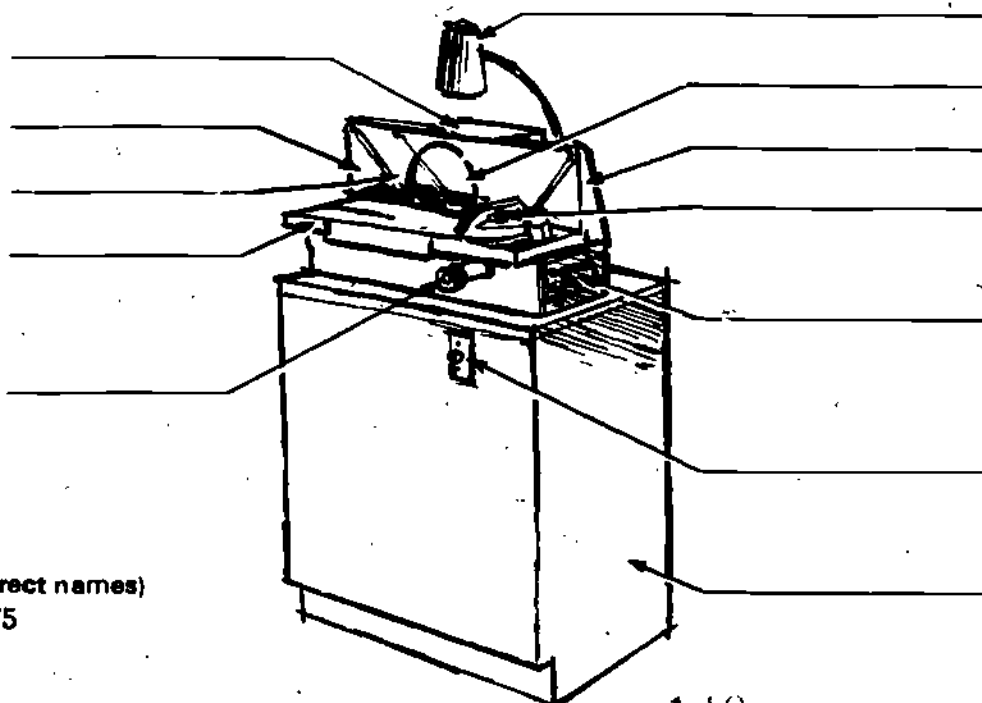

(Print the correct names)
12.75

For Safety —

1. Operate only with instructor's permission and after you have received instruction.
2. Remove jewelry, eliminate loose clothing, and confine long hair.
3. Make sure all guards are in place and operating correctly.
4. Always use proper eye protection.
5. Make all adjustments with the power off.
6. Be sure cutter is tightly held in the collet and material is securely held by a vise, clamps, or magnetic chuck.
7. Check spindle rotation, speed, depth of cut and all power feed adjustments before starting the cut.
8. Keep hands away from the cutter. Remove chips with a brush after the machine is turned off.
9. Once a cutting pass is made do not back out or return to the starting position without proper clearance.
10. Remain with the machine for the duration of the cut.

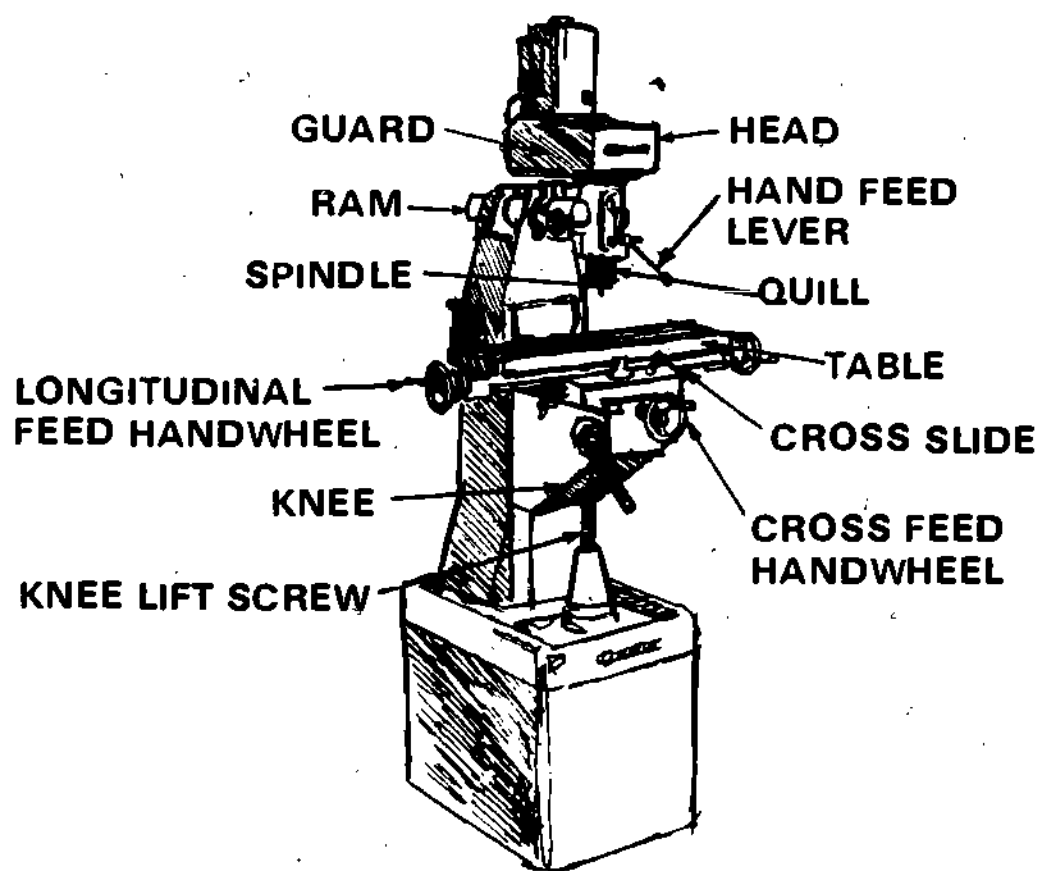

12.76

Vertical Milling Machine

S

Name _____

Class _____

Date _____ Grade _____

Safety Quiz

(Circle True or False)

1. If a brush is used it is safe to remove chip while the machine is running. T F
2. All adjustments have to be made with the power turned off. T F
3. If machine is running slow eye protection is not necessary. T F
4. You can back out of a cut at any time without raising the quill or moving the table. T F
5. The work piece must be securely fastened to the table before beginning the cut. T F

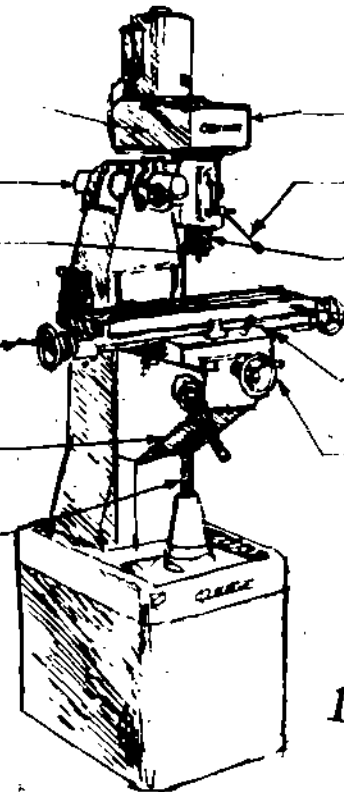

(Print the correct names)

12.77

142

For Safety —

1. Operate only with instructors permission and after you have received instruction.
2. Remove jewelry, eliminate loose clothing, and confine long hair.
3. Make sure all guards are in place and operating correctly.
4. Always use proper eye protection.
5. Work must be balanced and securely held between centers or mounted on a face plate.
6. Rotate spindle by hand to check clearance before starting the lathe.
7. Make sure safety shield is lowered.
8. Tool rest must be $1/8$ " from the work piece and adjusted to the proper height for the tool being used.
9. Be sure the lathe is running at the proper speed for the operation.
10. Remove the tool rest and base or support before sanding or polishing.
11. Make sure lathe cutting tools are sharp and use the correct tool for the operation.

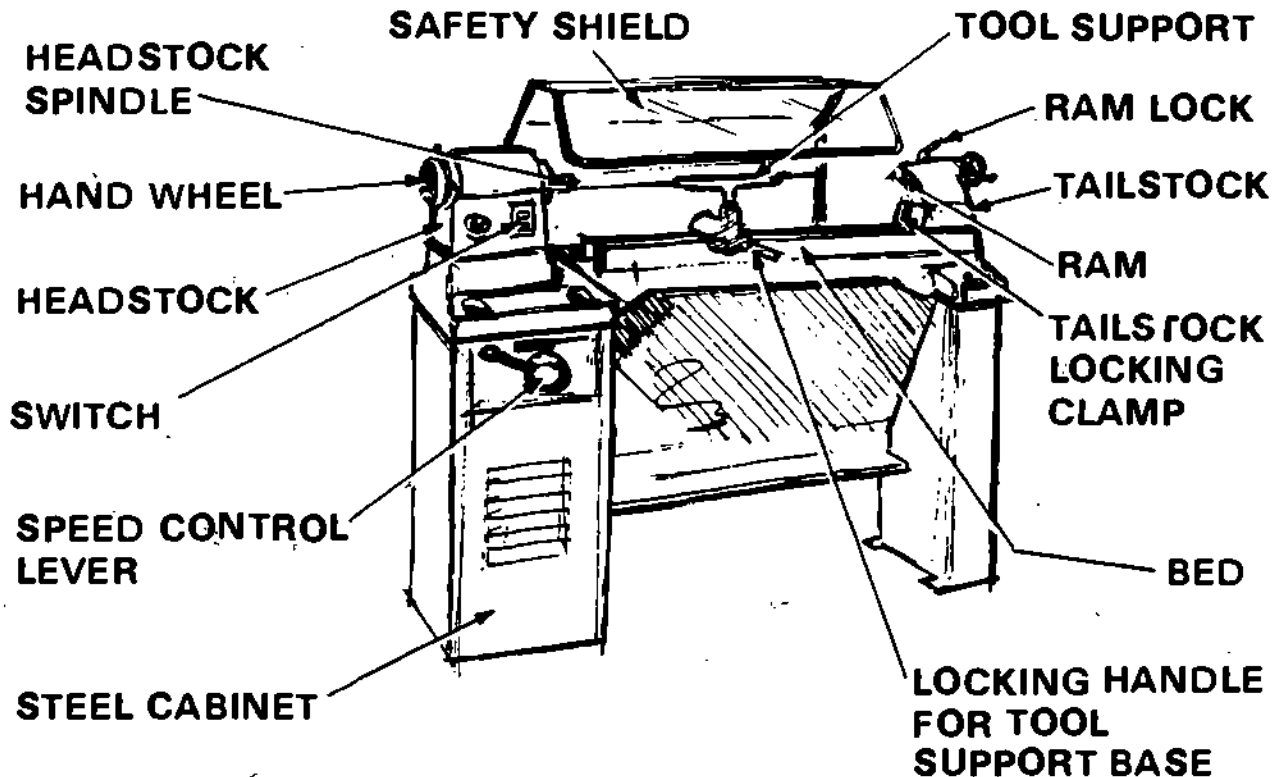

12.78

S _____

Name _____

Class _____

Date _____ Grade _____

Safety Quiz

(Circle True or False)

1. The speed of the machine is not important for safe operation. T F
2. A space of 1" is safe between the tool rest and the work. T F
3. Eye protection is not necessary during operation. T F
4. Dull tools may be used for a roughing operation. T F
5. The tool rest should be removed while sanding. T F
6. It is safe to turn work that is not balanced. T F
7. Long sleeves may be worn while operating the lathe. T F
8. The cutting tools should be held loosely. T F

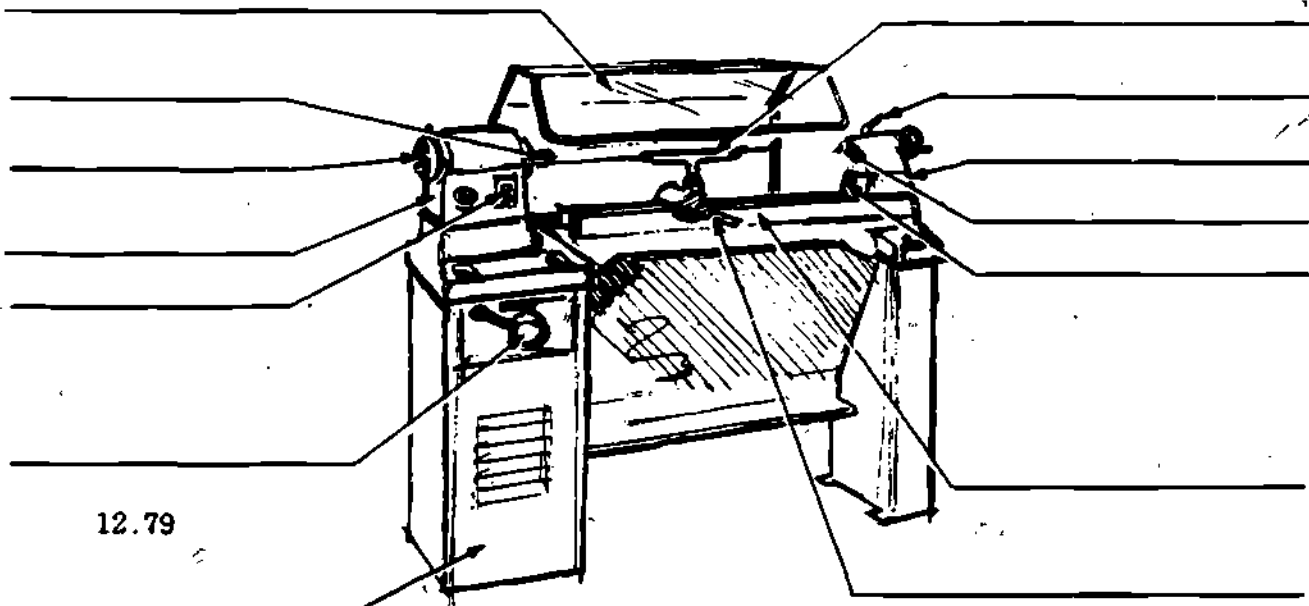

12.79

(Print the correct names)

For Safety —

1. Operate only with instructors permission and after you have received instruction.
2. Remove jewelry, eliminate loose clothing, and confine long hair.
3. Make sure all guards are in place and operating correctly.
4. Always use proper eye protection.
5. All adjustments for cutter heighth and fence position should be made with the power off.
6. Guards and hold downs should be checked for proper operation.
7. Choose the correct cutter and collars for the operation.
8. Expose only the amount of cutter necessary to do the job. Use additional fixtures if necessary.
9. Always use a starting pin for free hand shaping .
10. Use the smallest table insert possible.
11. Use three wing-one piece cutters when ever possible.
12. Brush away dust and chips only when the machine is stopped.

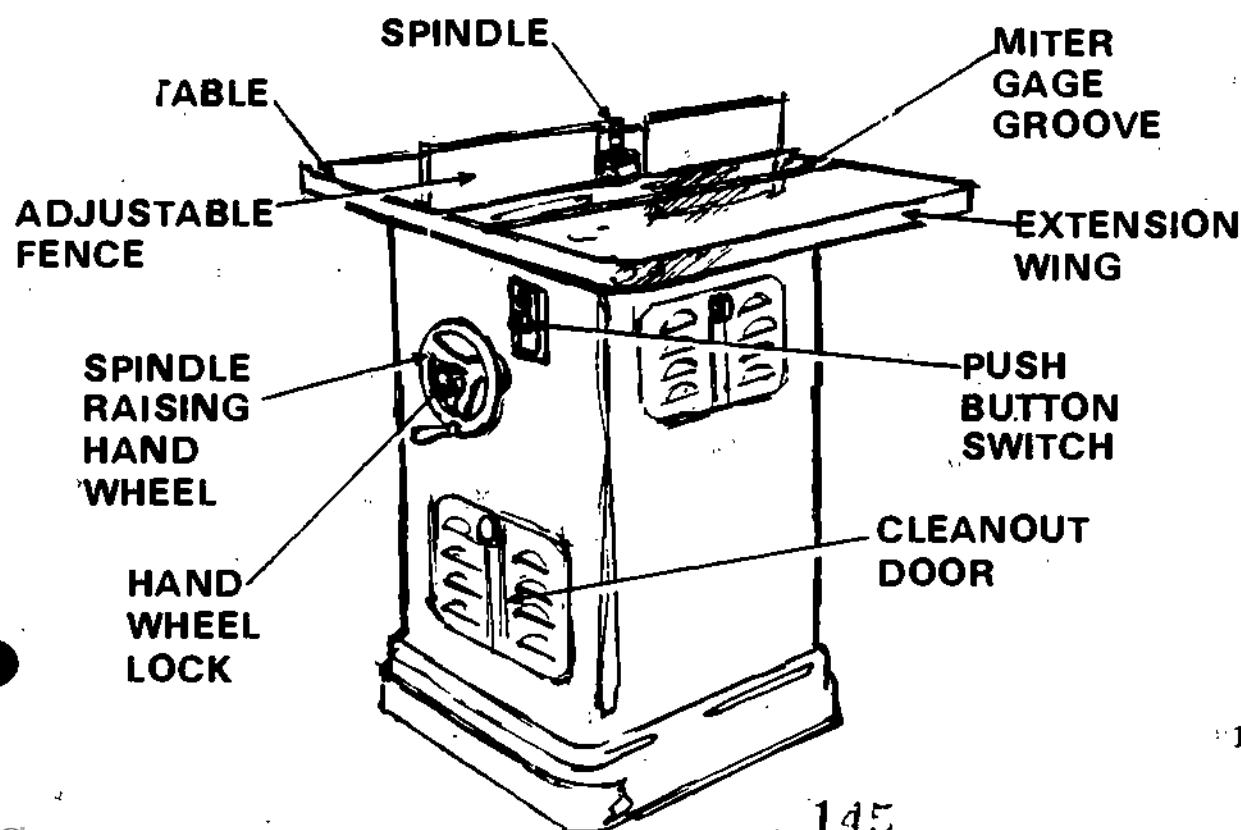

#12.80

S _____

Name _____

Class _____

Date _____ Grade _____

Safety Quiz

(Circle True or False)

1. In most cases guards and hold downs only get in the way. T F
2. Often special or custom fixtures must be made to do a job safely. T F
3. A starting pin is not necessary. T F
4. The largest table insert should always be used. T F
5. A brush should be used to brush away chips when the machine is running. T F
6. Three wing cutters are safer than a cutter head. T F

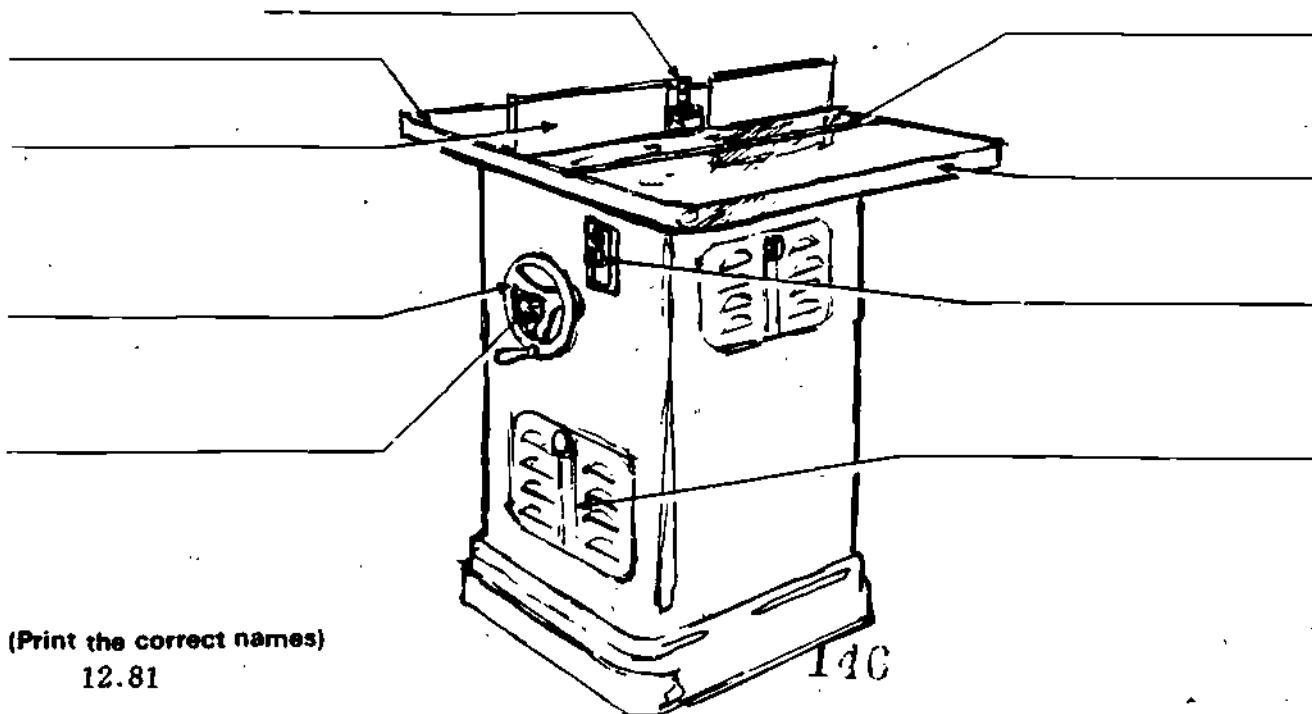

(Print the correct names)

12.81

SAFETY RULES FOR PORTABLE ELECTRIC HAND TOOLS

1. Instructor permission must be obtained before using portable electric tools.
2. Be sure that the switch is in the "off" position before you "plug" in the electric cord.
3. Eye protection must be worn when operating all portable electric tools.
4. The switch on each equipment handle should be the constant pressure (dead-man) type. That is, when pressure is released, power is shut off.
5. Be sure that equipment is properly grounded - do not use in wet areas.
6. Do not wear loose or baggy clothing that could be caught in revolving parts.
7. Before starting, be sure that you have a good footing and that your work area is free of obstacles.
8. The electric cord should be inspected for breaks or exposed wires before using.
9. Excessive pressure while operating portable electric tools may damage the tool and cause an accident.
10. All work should be properly secured before applying the tool.
11. Guards should be inspected before starting, to see that they function properly.
12. When portable electric saws are used, care must be taken to avoid cutting through the power supply and extension cords.
13. When portable electric saws are used, the student must avoid "over-reaching" when completing a cut. Work should be positioned and secured in a manner that allows the tool operator to "walk through" the cut safely.
14. Stock must be positioned and secured in a manner that allows cutting without binding of the saw blade of portable circular and bayonet-type saws.
15. Disconnect the cord plug from the power outlet before making any adjustments or replacing a blade or cutter.
16. If an extension cord must be used, make sure it is 12 gauge wire or heavier for lengths up to 100 feet and 10 gauge or heavier for lengths up to 150 feet.

5

17. Never run a portable electric tool where there is danger of explosion or fire due to the presence of naphtha, gasoline, benzene or other inflammable substance.
18. Keep your fingers away from blades or cutters.

For Safety —

1. Operate only with instructors permission and after you have received instruction.
2. Remove jewelry, eliminate loose clothing, and confine long hair.
3. Make sure all guards are in place and operating correctly.
4. Always use proper eye protection.
5. Be sure throttle is in the off position before connecting to air supply.
6. Always use impact type sockets designed for use with power equipment.
7. Make sure work is secure or held with clamps or tightly in a vise.
8. Set torque control for correct tightness before starting the job.
9. Be sure both hands are free to properly operate an impact tool. Maintain balance and firm footing at all times.
10. Always use the tool in short bursts of power.
11. Quick change coupling should be a end of hose whip, not at the tool.
12. Always disconnect the tool when not in actual use.

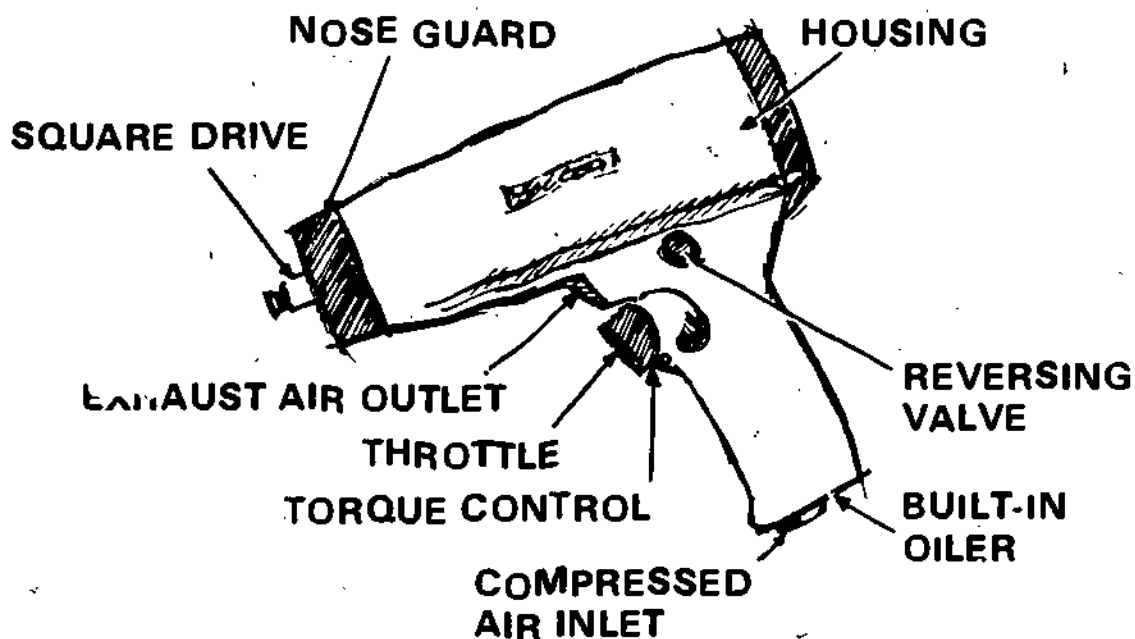

12.84

Portable Air Impact Wrench

s

Name _____

Class _____

Date _____ Grade _____

Safety Quiz

(Circle True or False)

1. It is safe to operate the impact wrench with one hand if the bolt or nut is not too tight. T F
2. Since there are no chips, eye protection is not necessary. T F
3. The sockets used must be designed for impact wrenches. Regular sockets are not adequate. T F
4. The tool should be disconnected from the air line at the end of the hose whip, not at the tool. T F
5. The impact wrench must be disconnected when not in actual use. T F
6. Short bursts of power should always be used to operate the tool. T F

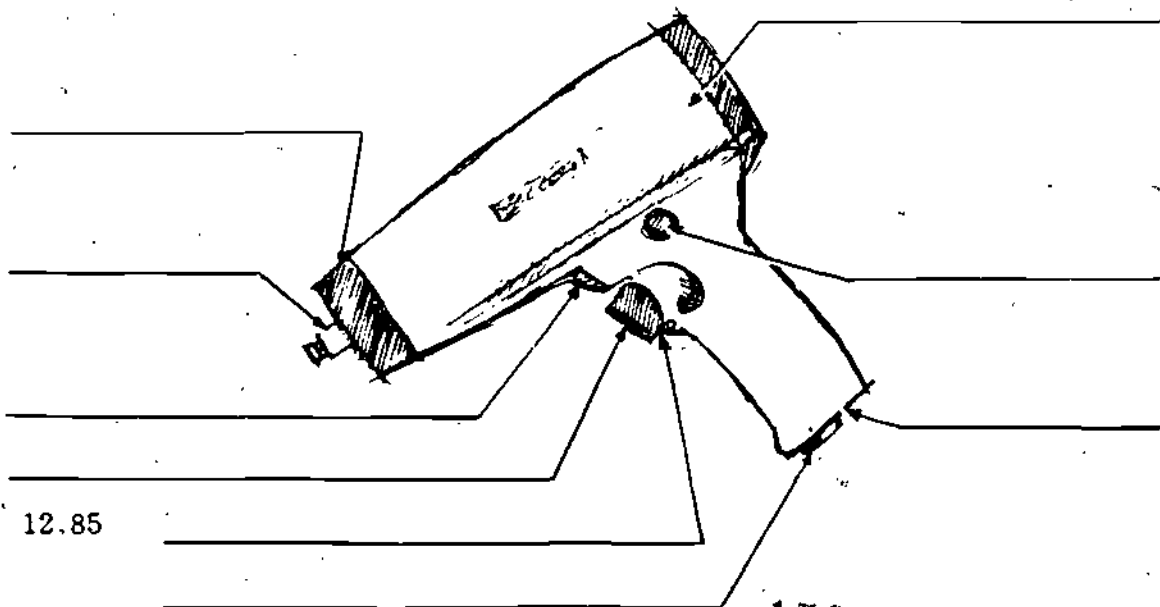

12.85

150

For Safety —

1. Operate only with instructor's permission and after you have received instruction.
2. Remove jewelry, eliminate loose clothing, and confine long hair.
3. Make sure all guards are in place and operating correctly.
4. Always use proper eye protection.
5. Make sure the blade is the correct type for the material and that it is tightly clamped in the chuck.
6. Be sure the switch is off before connecting to the power source.
7. Use vise or clamps to securely hold material to be cut.
8. Keep cutting pressure constant, do not force the blade into the work.
9. Always keep the base tightly against the material being cut.
10. Do not set the saw down on the bench until it has stopped.
11. If the blade is in the tool be sure and lay the tool on its' side.

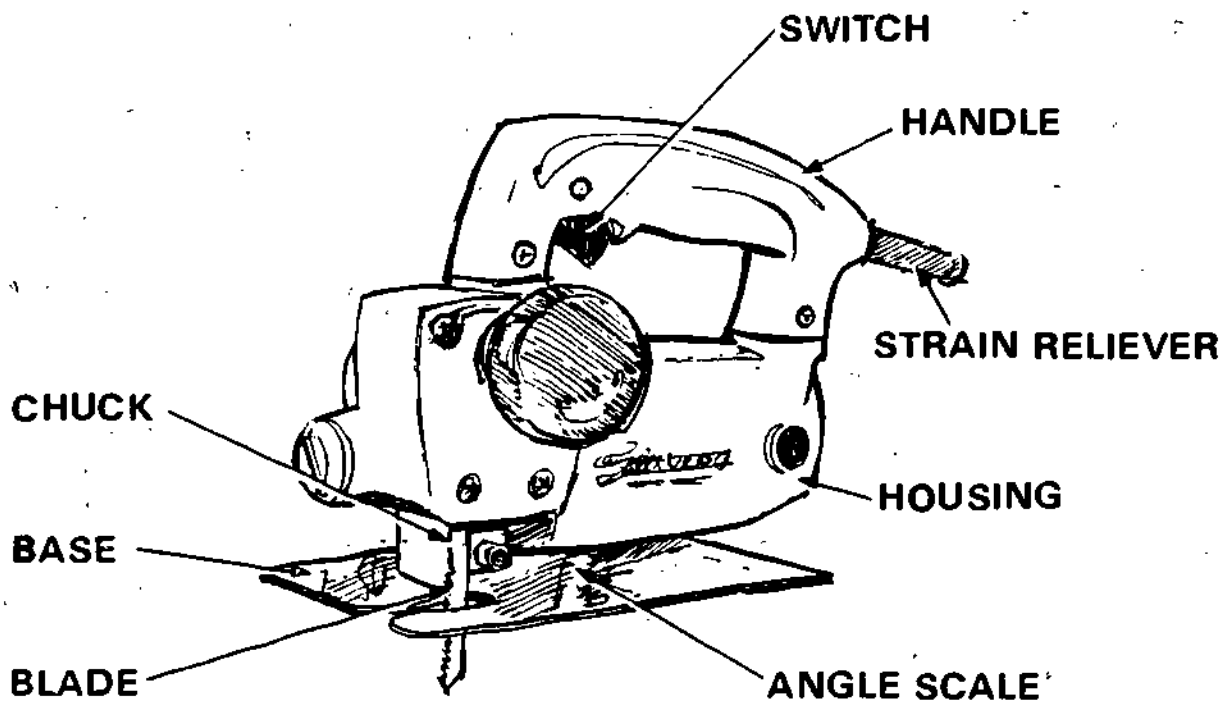

12.86

Sr. _____

Name _____

Class _____

Date _____ Grade _____

Safety Quiz

(Circle True or False)

1. Any blade will safely cut any kind of material. T F
2. Material should be held securely before starting to cut. T F
3. Cutting pressure should be constant without forcing the blade into the work. T F
4. The base should always be flat against the work, even when the saw is tilted. T F
5. The saw can be stored using the blade and the rear of the base for support. T F
6. The housing and handle should be kept free of grease, chips and dust. T F

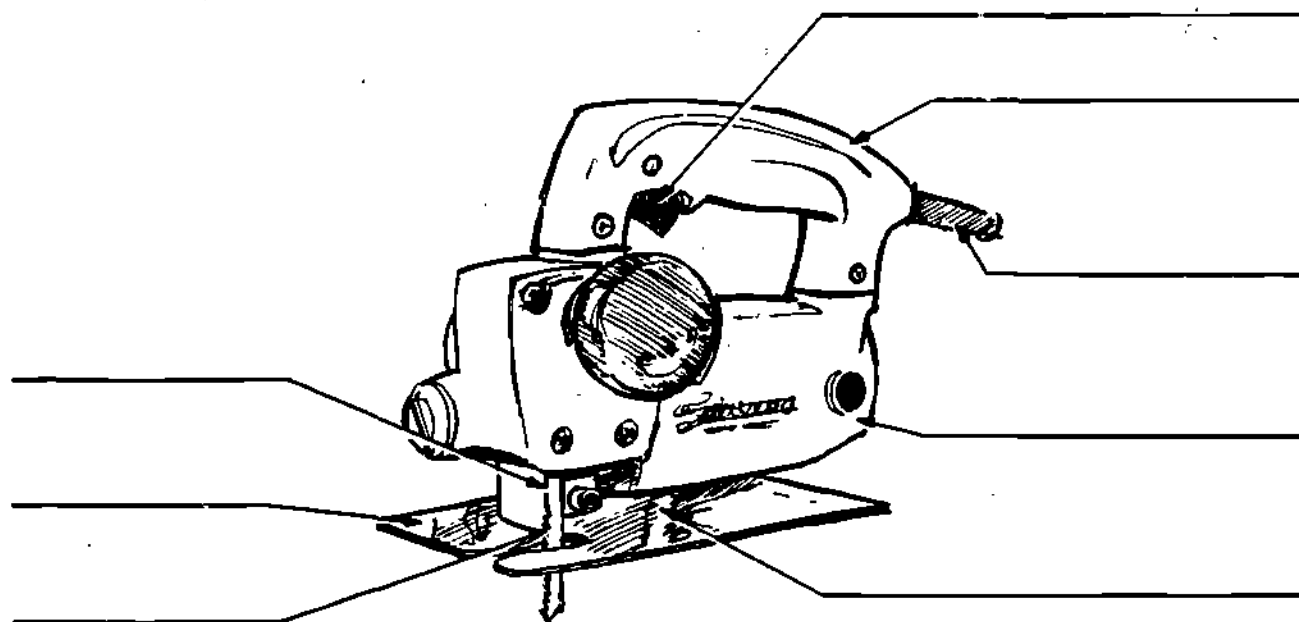

12.87
(Print the correct names)

For Safety —

1. Operate only with instructor's permission and after you have received instruction.
2. Remove jewelry, eliminate loose clothing, and confine long hair.
3. Make sure all guards are in place and operating correctly.
4. Always use proper eye protection.
5. Check to see if belt is in good condition, tracking properly, and is the correct grit size for the job.
6. Be sure switch is off before connecting to power source.
7. Start sander above work; let rear of belt touch first then level the tool. Do not tilt sideways.
8. Sand in direction of grain moving back and forth over a large area. Do not pause in one spot.
9. Keep electrical cord and dust bag away from working area.
10. Lift sander off the work and wait until it has stopped before placing on the bench.

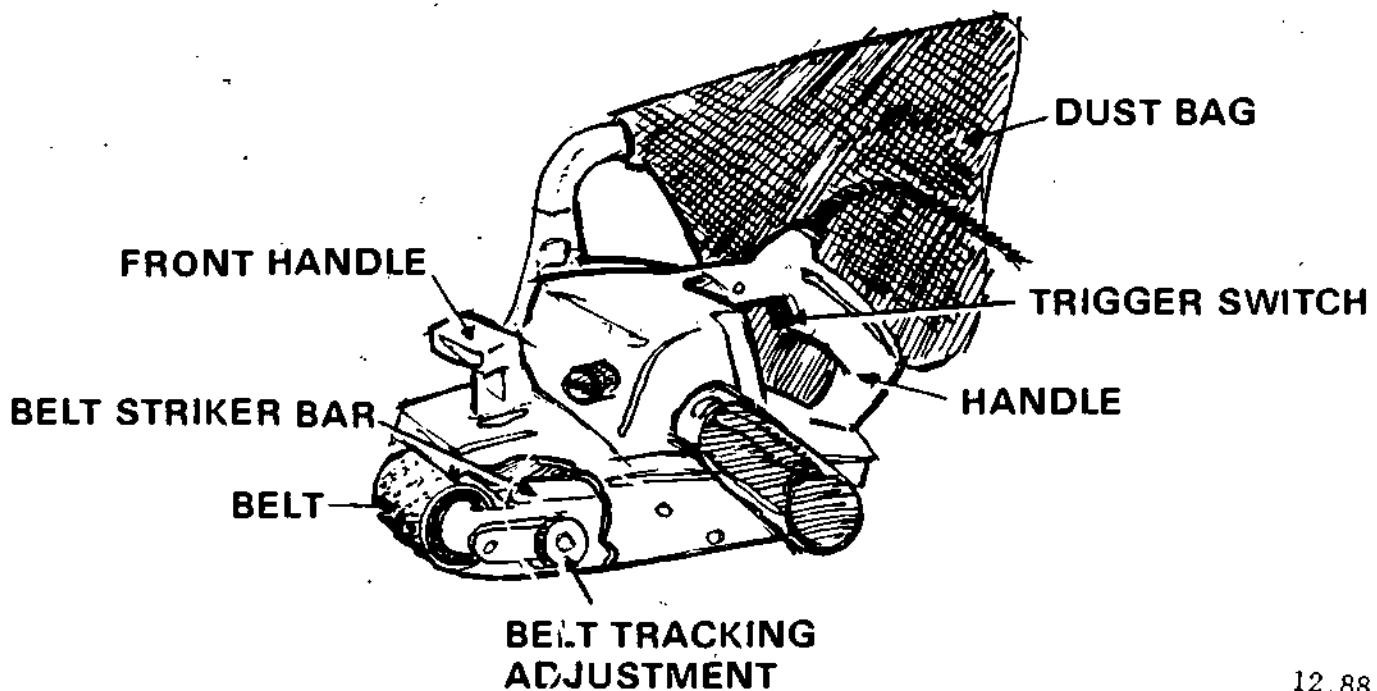

12.88

S

Name _____

Class _____

Date _____ Grade _____

Safety Quiz

(Circle True or False)

- 1. Proper belt is not a real factor in safe operation. T F
- 2. The sander should be resting flat on the work piece when starting. T F
- 3. If a firm grip is maintained on both handles it is not critical to remove jewelry. T F
- 4. There is a relation between selecting the correct belt for the job and safety. T F
- 5. The tool should never be tilted or allowed to pause in one spot. T F

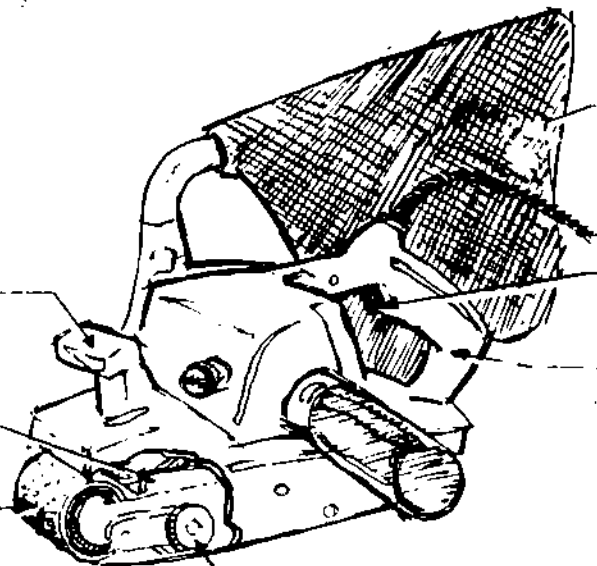

For Safety —

1. Operate only with instructor's permission and after you have received instruction.
2. Remove jewelry, eliminate loose clothing, and confine long hair.
3. Make sure all guards are in place and operating correctly.
4. Always use proper eye protection.
6. Before connecting to the power source be sure the switch is in the off position.
7. Make sure back up pad and disc are securely fastened to the tool. Unplug the sander when changing discs.
8. Do not allow the edge of the disc to touch the edge of the stock.
9. Stand clear of the spark line or spark area.
10. Sand or finish with a stroking motion; do not pause in one spot.
11. Set grinder or sander on back or on rubber stand when not in use and disconnect from power source.

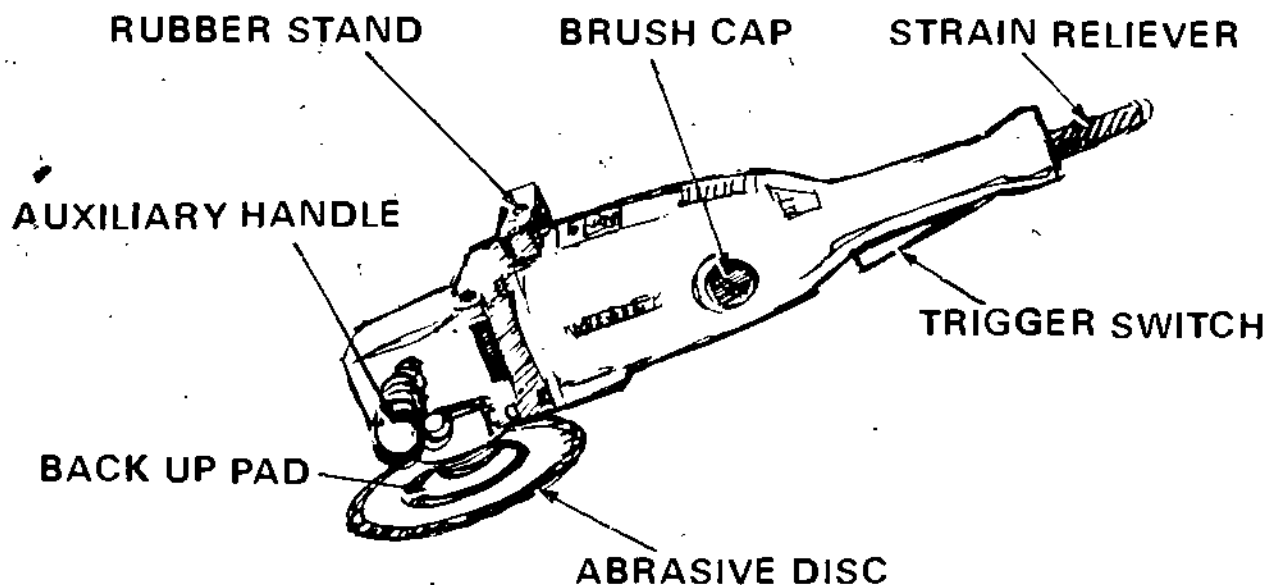

Portable Disc Sander

12-00

S _____

Name _____

Class _____

Date _____ Grade _____

Safety Quiz

(Circle True or False)

1. The sparks caused by grinding or sanding are warm but not dangerous. T F
2. In order to remove material fast it is safe to grind steady in one spot. T F
3. It is advisable to wear protective clothing while using this tool. T F
4. A fast rolling action takes place when the edge of the disc touches the edge of the stock which can throw the grinder or sander. T F
5. The grinder or sander should be unplugged and set on its' back when not in use. T F

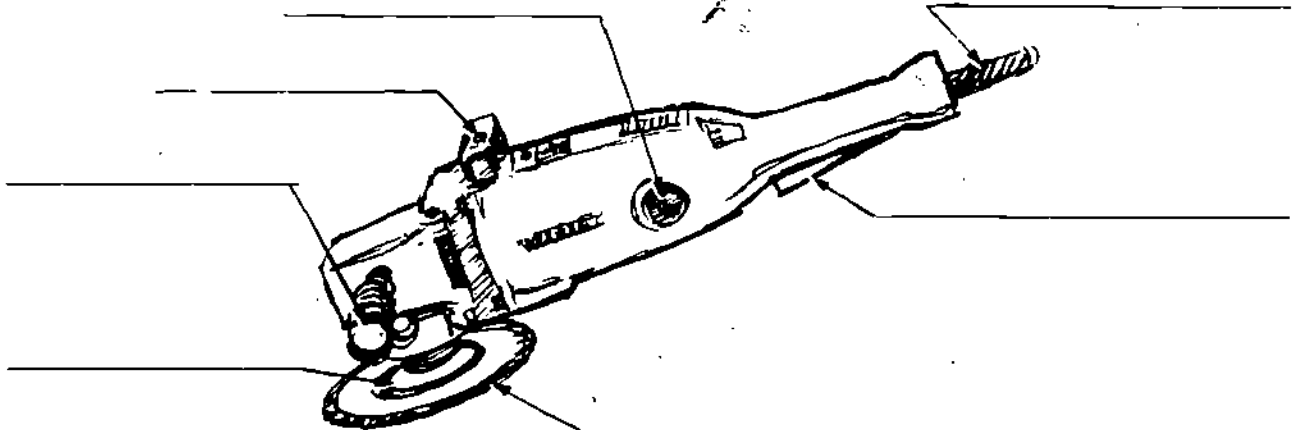

For Safety —

1. Operate only with instructors permission and after you have received instruction.
2. Remove jewelry, eliminate loose clothing, and confine long hair.
3. Make sure all guards are in place and operating correctly.
4. Always use proper eye protection.
5. Make sure that telescoping guard returns automatically to cover the blade after each cut.
6. Check the base setting for the proper depth of cut.
7. Make sure the power cord is clear of the blade.
8. Be sure the material you are cutting is adequately supported.
9. Do not start the cut until the saw has reached full speed.
10. Advance the saw slowly, straight through the work. Do not twist or turn the tool.
11. If the saw blade binds or smokes, stop cutting immediately.
12. The blade should be extended below the work until the blade Gullets clear the material.
13. Do not set saw down until blade stops.

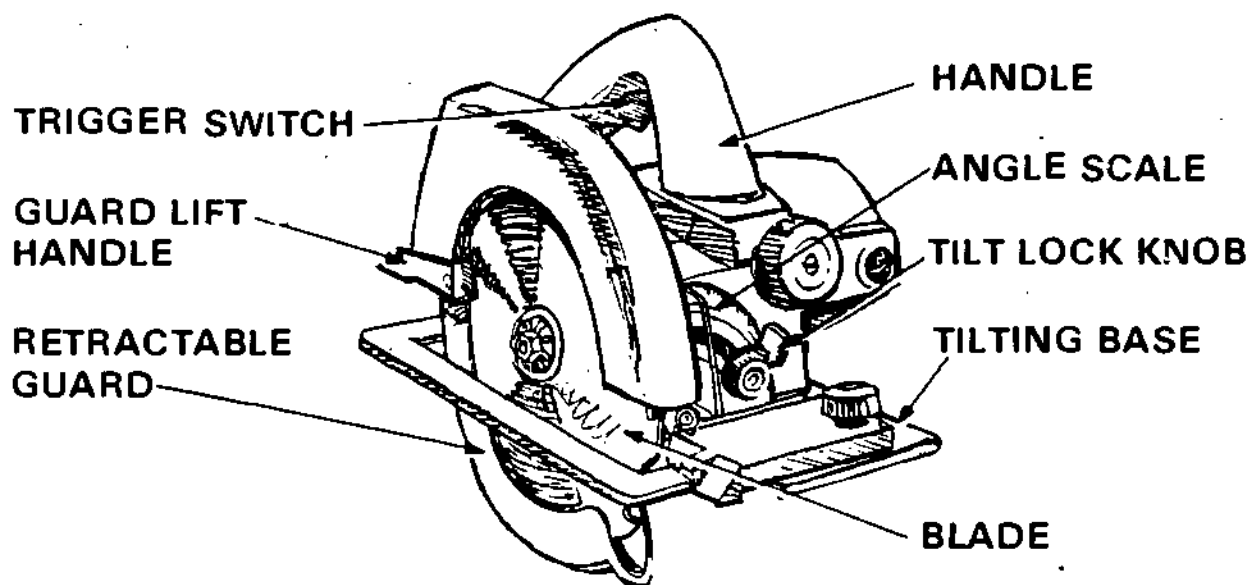

Portable Electric Circular Saw

12.92

Portable Electric Circular Saw

S

Name _____

Class _____

Date _____ Grade _____

Safety Quiz

(Circle True or False)

1. Permission should be obtained before operating this machine. T F
2. In certain cases the guard should be wedged so that it will not be operable. T F
3. Eye protection is not necessary when using this machine. T F
4. You should not set the saw down until it has completely stopped. T F
5. The saw blade should extend at least 1" beyond the thickness of the material being cut. T F
6. This saw can safely be used for cutting curves. T F

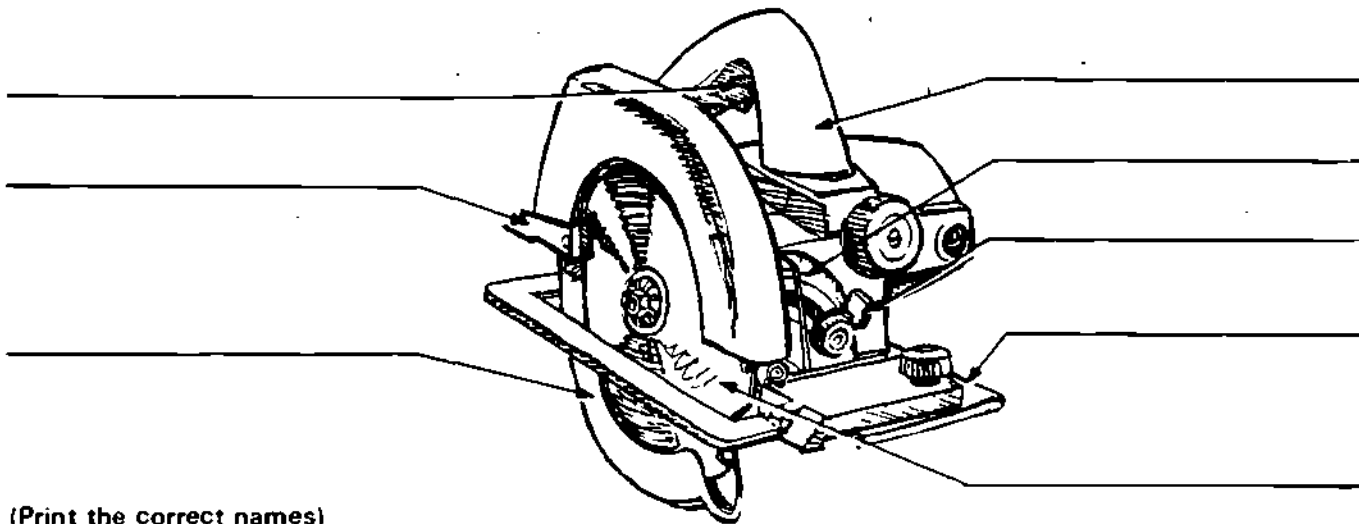

(Print the correct names)
12.93

For Safety —

1. Operate only with instructors permission and after you have received instruction.
2. Remove jewelry, eliminate loose clothing, and confine long hair.
3. Make sure all guards are in place and operating correctly.
4. Always use proper eye protection.
5. "Unplug" the drill when changing bits.
6. Make sure switch is off and key removed before connecting to power source.
7. Mark hole location with center punch (metal) or AWL (wood) before drilling.
8. Be sure work is tightly clamped or secure before drilling.
9. Drill with straight even steady pressure.

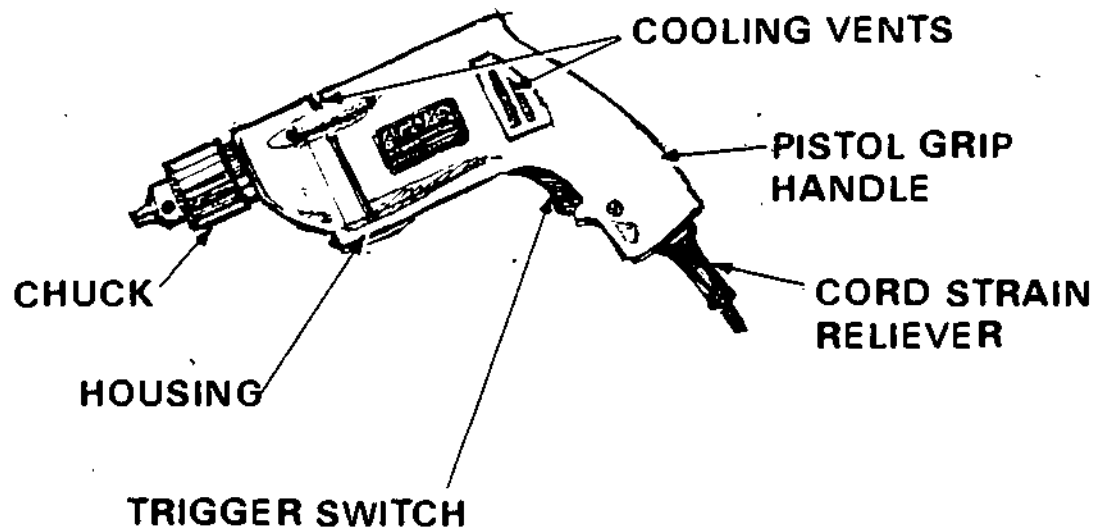

12.94

Portable Electric Drill

S _____

Name _____

Class _____

Date _____ Grade _____

Safety Quiz

(Circle True or False)

1. Eye protection is not really necessary when drilling wood. T F
2. The drill should be unplugged when changing bits. T F
3. It is alright to carry the drill by the cord. T F
4. Even steady pressure should be used when drilling. T F
5. Work should be clamped while drilling. T F

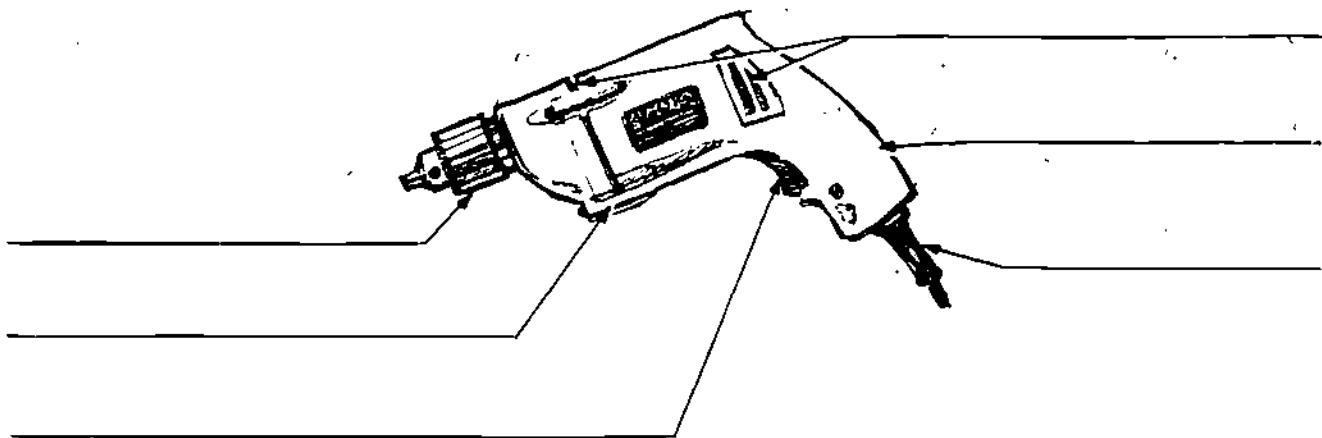

(Print the correct names)

12.95

100

For Safety —

1. Operate only with instructors permission and after you have received instruction.
2. Remove jewelry, eliminate loose clothing, and confine long hair.
3. Make sure all guards are in place and operating correctly.
4. Always use proper eye protection.
5. Be sure switch is in off position before connecting to the power source.
6. Make sure abrasive sheet is in good condition and properly installed on the tool.
7. Start the tool above the work, set it down evenly and move slowly over a wide pattern area.
8. Lift the sander from the work before stopping the motor.
9. Do not set the sander on the work bench until it has stopped running.
10. Never lift or carry any portable electric tool by the power cord.

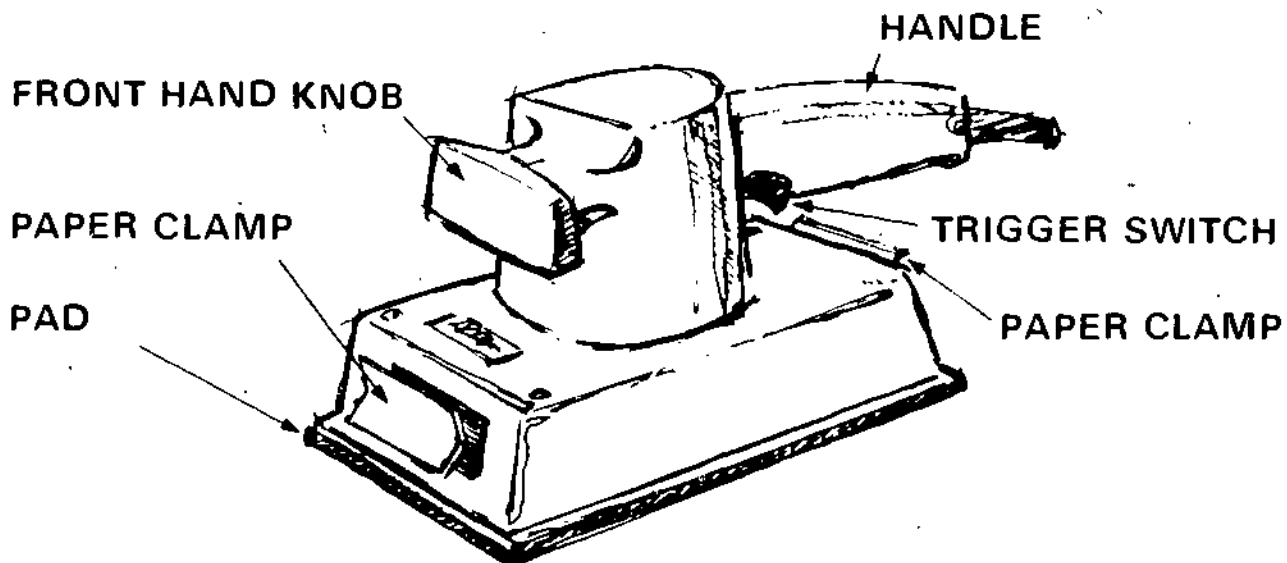

Portable Electric Finishing Sander

12.96

Portable Electric Finishing Sander

S _____

Name _____

Class _____

Date _____ Grade _____

Safety Quiz

(Circle True or False)

1. Eye protection must be worn when using the sander. T F
2. The abrasive sheet can be loosely clamped yet still be safe and efficient. T F
3. The sander should never be carried by the power cord. T F
4. The tool should be turned on only after it is placed tightly on the material to be sanded. T F
5. Lift the sander from the work before turning it off. T F

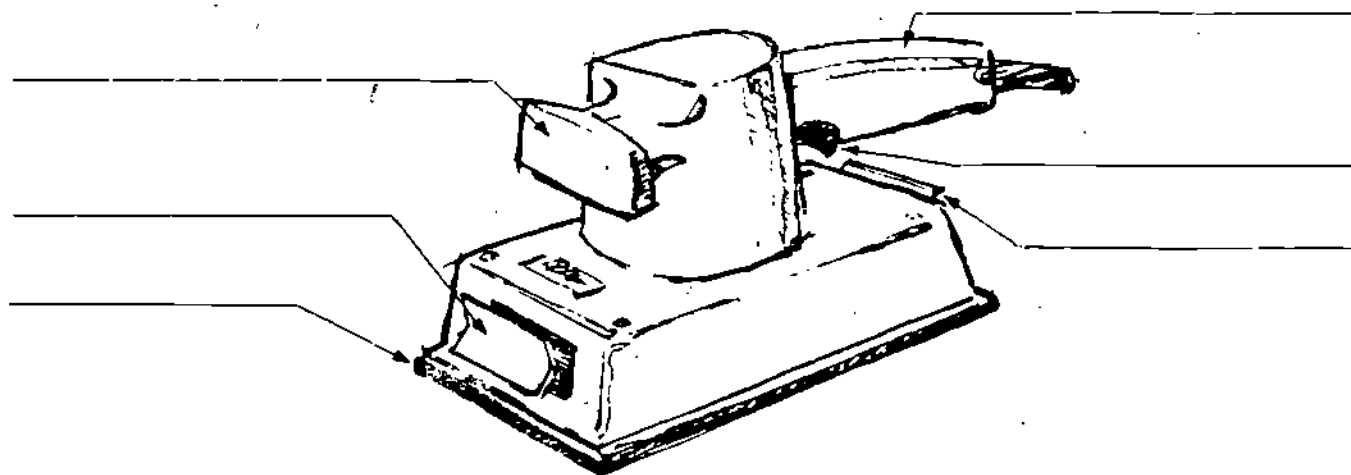

(Write the correct names)
12.97

For Safety —

1. Operate only with instructors permission and after you have received instruction.
2. Remove jewelry, eliminate loose clothing, and confine long hair.
3. Make sure all guards are in place and operating correctly.
4. Always use proper eye protection.
5. Before connecting to the power source make sure the switch is in the off position.
6. Make all adjustments with the plane disconnected from the power source.
7. Place front shoe on the work piece, start motor, then move plane over work keeping pressure and speed constant.
8. Keep fence and the rear shoe tightly against the work piece until the cutter has cleared the work.
9. Keep hands on handle and motor housing, away from the cutter head.
10. Be sure of clearance for the motor.

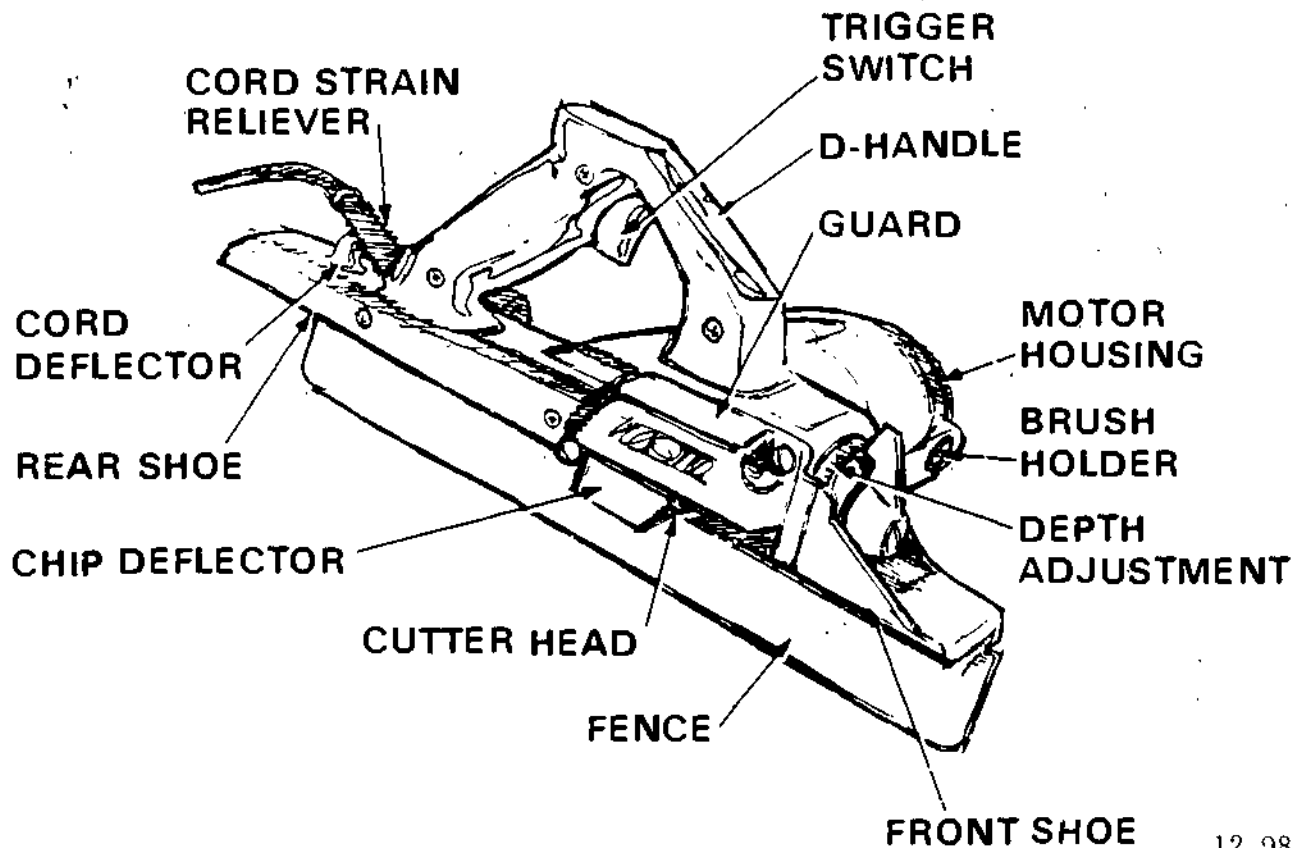

12.98

Portable Electric Plane

S _____

Name _____

Class _____

Date _____ Grade _____

Safety Quiz

(Circle True or False)

1. Since the cutter will not touch, it is alright to set the plane on the bench while still running. T F
2. The plane will cut deeper the more pressure is applied. T F
3. The plane should be disconnected before adjusting the depth of cut or the fence. T F
4. Eye protection is required when using a power plane. T F
5. The plane should be kept firmly against the work piece until the cut is completed. T F
6. The chip deflector is of no real safety value and can be removed. T F

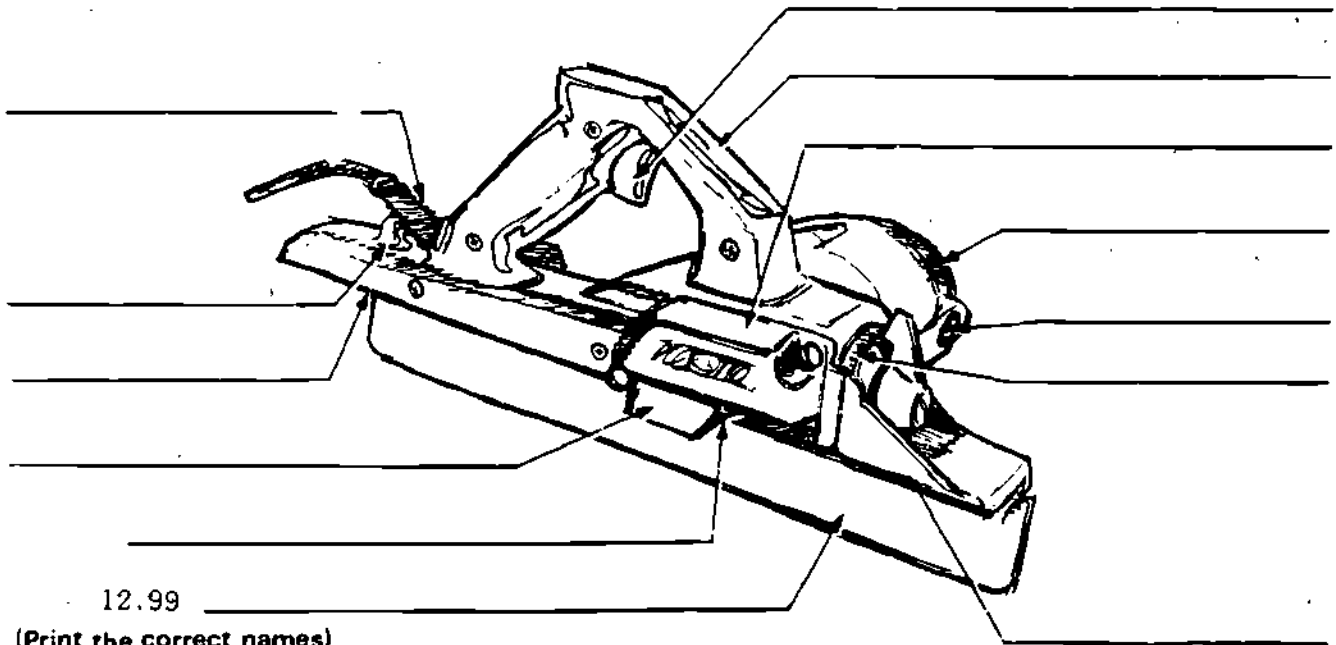

12.99

(Print the correct names)

For Safety —

1. Operate only with instructors permission and after you have received instruction.
2. Remove jewelry, eliminate loose clothing, and confine long hair.
3. Make sure all guards are in place and operating correctly.
4. Always use proper eye protection.
5. Be sure switch is off before inserting plug into power source.
6. Be sure collet chuck is tight and bit is secure.
7. Make sure work piece is clamped or rigidly held and the area of router travel is free of obstructions.
8. Hold router with both hands and cutting pressure should be constant. Do not force or jam into work.
9. Make a trial cut in a piece of similar scrap material.
10. Disconnect from power source when changing bits, making adjustments, or when router is not in use.

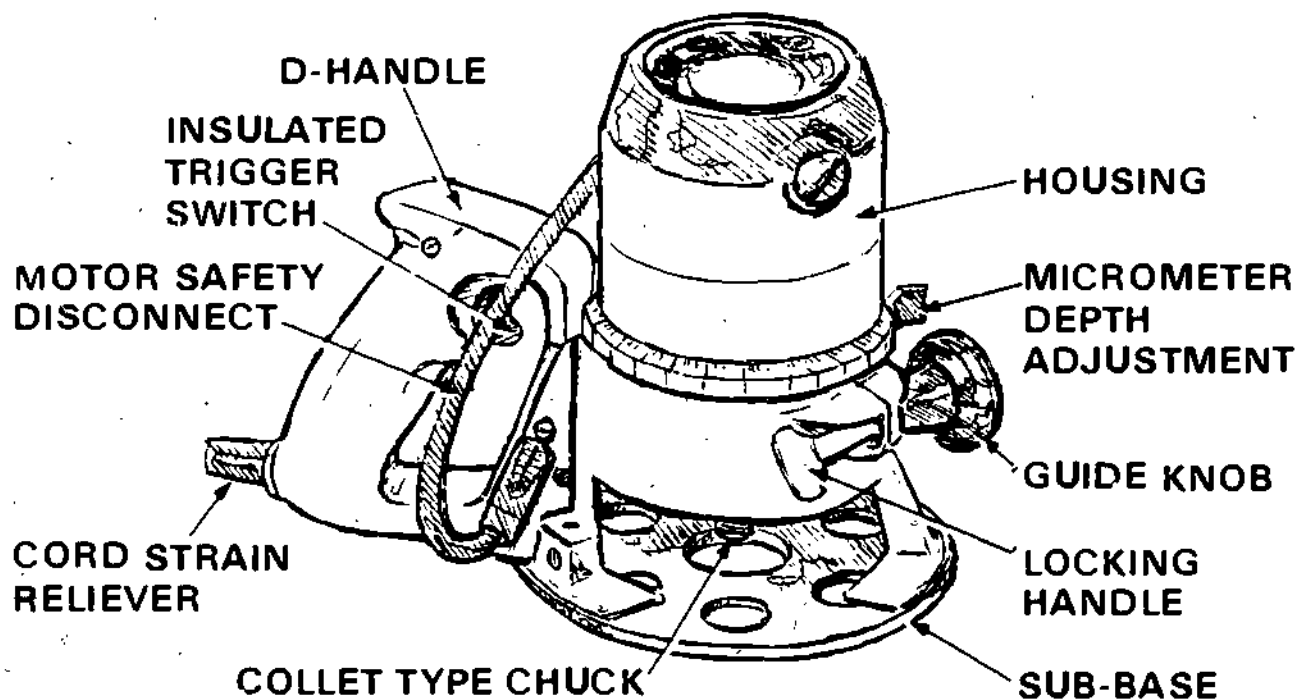

12.100

HAND TOOL SAFETY

When improperly used, even a safe tool can cause accidents. Do not assume that all students know how to identify and/or use ordinary hand tools. They should be trained to choose the proper tool for each job and to use it only for its intended purpose.

All necessary tools should be available so the student does not have to improvise. Accidents occur more often when one tool is substituted for another. Remember, it is also important to use the correct size and type of tool such as a hammer, wrench, or screwdriver.

Three major causes of hand tool accidents are:

1. Using the wrong tool for the wrong job.
2. Using the proper tool incorrectly.
3. Using a damaged or defective tool as the result of poor inspection and maintenance practices.

SAFETY RULES FOR HAND TOOLS

1. Wear adequate eye protection devices at all times in the laboratory.
2. Select the proper size and type of tool for the job. Learn and follow the correct procedure for using each tool.
3. Cutting tools must be properly sharpened and in good condition.
4. Keep your hands free of oil and grease.
5. Handle sharp-edged and pointed tools with care; carry in such a way as to protect yourself and others.
6. Secure small or short work with a vise or clamp.
7. Never carry tools in your pockets.
8. Use tools only for the purpose for which they were intended.
9. Do not use tools with loose or cracked handles.
10. Keep punches and chisels in good condition. Mushroomed heads may chip and cause injuries.
11. Use a file only when it is equipped with a handle.
12. Never pry, hammer on, or hammer with a file; it may shatter.
13. Do not use screw drivers as chisels or pry bars.

14. The use of a "cheater" or any other means for increased leverage is hazardous. All wrenches are designed to a specific size-length-strength ratio.
15. Do not use a hard hammer on another hardened surface.
16. When finished with a tool, clean it and return it to the proper storage place.
17. Report any breakage or malfunctions to your instructor.

HOUSEKEEPING PRACTICES

1. Provide for the daily removal of all sawdust, shavings, metal cuttings and other waste material.
2. Provide properly marked boxes or bins for various kinds of scrap stock.
3. Utilize sturdy racks and bins for materials storage, arranged to keep material from falling on students and to avoid injuries from protruding objects.
4. Employ a standard procedure to keep floors free of oil, water and foreign material.
5. Provide brushes for the cleaning of equipment after each use.
6. Provide regular custodial service in addition to the end of class cleanup.
7. Prohibit the use of compressed air to clean clothing, equipment and work areas.
8. Keep walkways and work areas free of all obstructions.
9. Floor surfaces must be maintained in a "non skid" condition.
10. Utilize a student personnel organization to insure total involvement in housekeeping and a more thorough cleanup.

HOUSEKEEPING

Good housekeeping is a key item in accident prevention. It takes the cooperation of all; it can't be the responsibility of the instructor and custodian alone. An effective housekeeping program will:

1. Reduce exposures to slips and falls;
2. Reduce fire hazards;
3. Remind individuals of their responsibilities in keeping the laboratory clean and orderly;

4. Organize the housekeeping effort so that everyone assumes their fair share of the task.

Good housekeeping cannot be accomplished by an occasional grand cleanup. A program must be developed for continual cleanup. The following are essential in a good housekeeping program:

1. The equipment is arranged to permit safe and efficient work practices.
2. Materials and supplies are neatly and safely stacked.
3. Sufficient waste containers are provided and used.
4. Floors are clean.
5. Combustible materials are properly disposed of or stored in approved containers.
6. Excess materials and debris are not allowed to remain on benches and in the work areas.
7. Regular inspections are made to maintain clean and orderly conditions.

Items that are necessary for good housekeeping in an industrial Arts laboratory are:

1. Adequate dust collecting system.
2. Suitable containers for scraps, shavings, chips and other waste material.
3. Adequate storage rooms, shelves, racks, and cabinets for materials and supplies.
4. Splash guards and collecting pans for all machines using oil and coolants.
5. Brooms, bench brushes, shop towels, and other cleaning equipment.

It is your responsibility to see that housekeeping tools, equipment and supplies are properly used.

MATERIALS HANDLING

According to the National Safety Council, nearly one in four disabling injuries is directly related to materials handling activities. These accidents include such things as slips and falls while carrying objects, back injuries and hernias from improper lifting practices, chemical and heat burns from failure to use protective clothing or equipment, and mashed or amputated fingers or toes from dropped objects.

Some of the things you can do to reduce the chance of injury to yourself or others when handling materials are:

1. Use the proper aids to handle the materials, such as tongs for hot materials, block and tackle or jacks to lift extra heavy items, and blocks or wedges to keep items from rolling.
2. Don't try to lift heavy objects without help; before you lift make clear who is giving the orders.
3. Use proper lifting techniques.
4. If the material is heavy or sharp use gloves or pads to assure a better grip or to avoid cuts. Be careful of splinters when handling lumber; wear gloves to handle rough lumber.
5. Before you pick up an object be sure that the path you intend to follow is clear.
6. With heavy objects, make a "first lift" before carrying it so that you can get the feel and position.
7. With long objects, such as pipe or ladders, have someone at each end so that they can be safely guided.
8. Be careful not to drop or set heavy objects on your feet or those of other people.
9. Stack materials so that there is no danger of slipping or falling during storage or removal.

ELECTRICAL SAFETY

The use of electricity has become so common that few people realize the potential dangers of electrical energy. Most of the accidents that are caused by electricity could have been avoided if the hazard had been recognized and if action had been taken to correct the adverse condition.

The instructor must realize that any electrical circuit is a potential hazard, regardless of the amount of voltage or current present.

The nature of the injury may be affected by the frequency of the current and the kind of electrical energy. Direct current is usually considered less hazardous than alternating current as far as shock is concerned, but is more likely to produce severe burns and tissue damage. The physical condition of the victim is another factor which has a bearing on the severity of electrical shock.

Electrical accidents are caused by unsafe conditions, unsafe practices, or a combination of both.

A study of accidents in the State of California reveals that "unsafe practices were reported in four out of five accidents. Using unsafe or defective tools or equipment led the list, while failure to de-energize equipment, using tools or equipment in an unsafe manner and working in hazardous places were next in order."

Causes of electrical accidents can be traced to (1) defective equipment, (2) unsafe work practices, and (3) lack of knowledge of the dangers of electricity.

1. Defective Equipment. Types of Equipment frequently involved in electrical accidents include motor - driven equipment, control devices, portable electric tools, switches, panels, cutouts, conductors, plugs and fuses, and electric extension cords. A variety of unsafe conditions involving the different types of equipment creates many electrical hazards. Some of the common defects of tools and equipment are listed as follows:
 - a. Improperly grounded equipment (ground wires missing, broken or improperly connected);
 - b. Open conduits, switch boxes, damaged or worn connections, and exposed live wires;
 - c. Insulation which is defective, inadequate, worn frayed, wet, oily or deteriorated, creating short circuit possibilities and energizing equipment frames;
 - d. Defective switches, receptacles, extension cords, and lamp sockets;
 - e. Dirty motor windings, improperly adjusted brushes, and worn commutators;
 - f. Improperly connected power tools and defective insulation in portable tools;
 - g. Broken housings, loose or vibrating machine parts which might contact and energize tool or machine frames and expose "live" surfaces to operator.
2. Unsafe Practices. Unsafe practices and work procedures result in electrical accidents and fires. Some of the common unsafe acts committed in the shop are:
 - a. Using ungrounded equipment and portable tools (except double insulated tools) or removing ground connections;
 - b. Using defective tools or equipment in need of repair;

- c. Using equipment which does not meet the approval of the Underwriters Laboratories for the intended use;
 - d. Unsafe cleaning of electrical panels, switch boxes, motors, and other electrical equipment with water or dangerous solvents;
 - e. Overloading of circuits or overfusing circuits by the use of wrong size or type of fuse;
 - f. Failure to use explosion-proof or other special wiring methods in hazardous locations.
 - g. Failure to positively lock out or otherwise de-energize and tag equipment or circuits to be worked on. Do not rely on gloves, rubber mats, etc., for electrical installation and repair.
 - h. Installation or extension of electrical facilities in a manner not meeting the National Electrical Code;
 - i. Repetitive closing of switches or circuit breakers when there is a fault on the circuit;
 - j. Using light duty, ungrounded extension cords for industrial service;
 - k. Failure to maintain clear access to electrical panels. Clearance of 30 inches is required by the Federal Code.
 - l. Use of extension cords in place of permanent wiring extensions;
 - m. Work practices which overload motors, insulation, wires or electrical accessories;
 - n. Disconnecting of electric cords by pulling on the cords rather than on the plug;
 - o. Use of metal ladders while working on electrical equipment;
 - p. Failure to label switch panels and boxes.
3. Lack of Knowledge: Teaching a basic understanding of electrical safety is part of an Industrial Arts Educational Program.

Ground Fault Protection - a recent development that can save lives. Devices are now readily available which give sure protection against electrocution or serious shock from defec-

tive portable tools or cords. Their use should be encouraged in all areas, but particularly where there is a serious shock hazard from wet conditions or other conditions causing massive grounding of the student.

In summary, an adequate program for the prevention and elimination of electrical hazards must rest upon:

- a. Intelligent selection and purchase of equipment;
- b. Correct installation of equipment;
- c. Education of students in the safe use of electrical energy;
- d. Periodic inspection of equipment;
- e. Regular maintenance.

FIRE SAFETY

1. Provide approved fire extinguisher in the shop area. Multi-purpose dry chemical units are most effective for general use. General purpose fire extinguishers should have at least a 2A:10 BC rating. Water back-up for extinguishers is always desirable. Multi-purpose dry chemical can damage delicate electrical equipment. CO₂ type extinguishers eliminate that problem.
2. Fire extinguishers should be located along normal paths of travel and must not be obstructed or obscured from view.
3. Store flammable liquids in approved (Underwriters Laboratories or Factory Mutual labeled) safety containers and cabinets.
4. Provide for the bulk storage of flammable materials in an area removed from the main school building.
5. Provide Underwriters Laboratories Listed oily waste containers for oily and paint soaked rags. It is a good policy to place waste with high spontaneous combustion potential in water filled containers. (See National Fire Protection Association pamphlet 30, para. 4450, "Flammable and Combustible Liquids Code.")
6. Provide for the inspection and testing of fire extinguishers at regular intervals to ascertain that they are fully charged and in proper working condition (See National Fire Protection Pamphlet 10, "Standard for Portable Fire Extinguishers" for details.) It is suggested that your school district adopt the labeling system using the Symbol Signs.
7. Provide instruction to students in the location and proper use of fire extinguishers and other fire fighting equipment.

8. Segregate oxidizers and oily material in storage. Do not use oxidizer (peroxide catalyst) containers for other purposes.
9. Post fire alarm and evacuation procedures.
10. Students should know remote shut-off valve or switch locations for gas or oil fired equipment and how to de-energize electrical equipment in an emergency.
11. Deluge showers would be desirable in all industrial arts laboratories, especially where there is danger of fire igniting clothing made of synthetic materials.
12. An approved fire blanket should be provided in each laboratory.

NEW FIRE EXTINGUISHER SYMBOLS

Picture symbols showing the uses for each of four types of fire extinguishers were approved for use in May, 1978. The reason for change was ease of recognition. It was felt that the old symbols, which showed a letter--A, B, or C--in a geometric shape, could be easily confused if you didn't know what the symbol meant.

The new symbols consist of three panels, each of which depicts the nature of one class of fire, and whether or not the extinguisher can be used on them.

Colors used in these symbols are important because they show at a glance the hazard for which an extinguisher is applicable. Panels printed in blue show the class of fire for which it is safe to use the extinguisher. Panels that show a class of fire on which it is dangerous to use the extinguisher are printed in black with a red slash running diagonally through the panel.

The symbol for Class "D" fires remains the same because this class of fire is rare. A class "D" fire occurs in combustible metals such as magnesium, titanium, zirconium, and sodium. The proper extinguisher must be used. Normal extinguishing agents should not be used on metal fires because there is a danger of increasing the intensity of the fire as a result of a chemical reaction.



New Fire Extinguisher Symbols

Use on "A" Types



Use on "A/B" Types

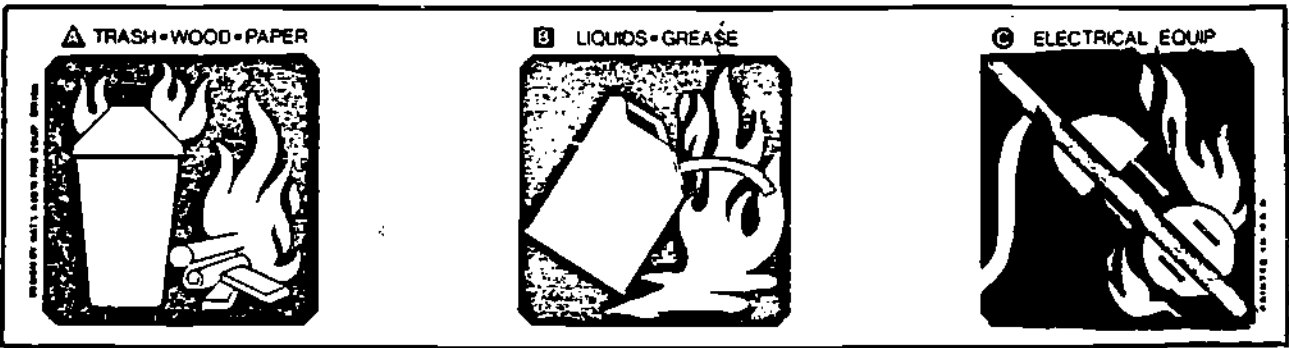

Use on "B/C" Types

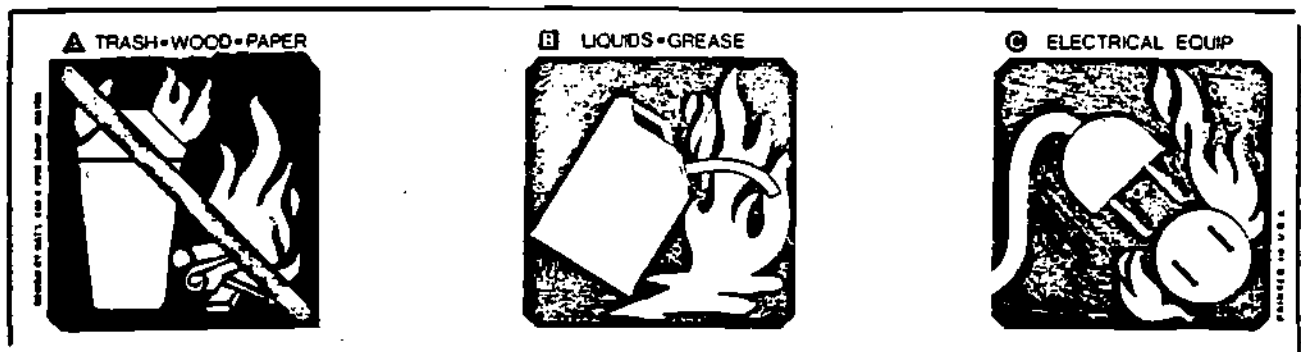



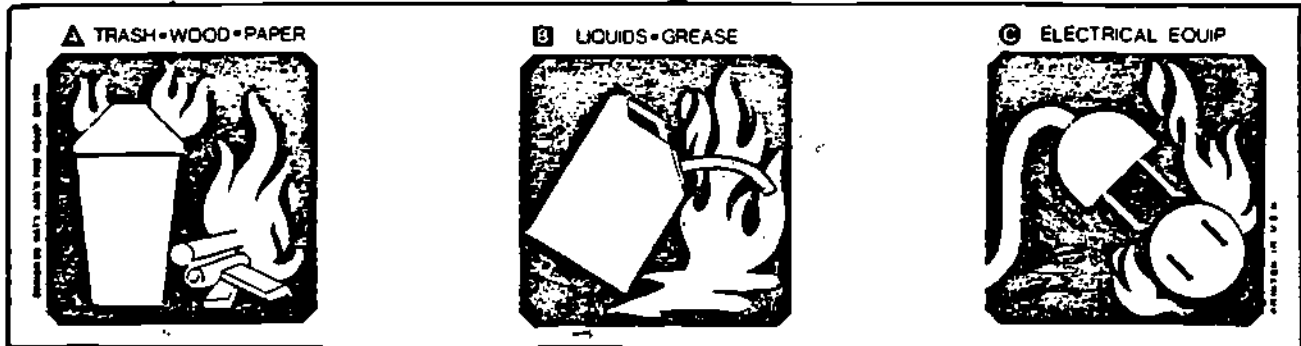

Use on "A/B/C" Types



indicates blue area on symbol.

KNOW YOUR FIRE EXTINGUISHERS

	WATER TYPE				FOAM	CARBON DIOXIDE	DRY CHEMICAL			
	STORED PRESSURE	CARTRIDGE OPERATED	WATER PUMP TANK	SODA ACID	FOAM	CD 2	SODIUM OR POTASSIUM BICARBONATE	STORED PRESSURE	MULTI-PURPOSE ABC	CARTRIDGE OPERATED
CLASS A FIRES WOOD, PAPER, TRASH HAVING GLOWING EMBERS 	YES	OBSOLETE	YES	OBSOLETE	OBSOLETE	NO (BUT WILL CONTROL SMALL SURFACE FIRES!)	NO (BUT WILL CONTROL SMALL SURFACE FIRES!)	NO (BUT WILL CONTROL SMALL SURFACE FIRES!)	YES	YES
CLASS B FIRES FLAMMABLE LIQUIDS, GASOLINE, OIL, PAINTS, GREASE, ETC 	NO	UPDATE YOUR FIRE EXTINGUISHING CAPABILITY—ASK FOR "TRADE-IN UPDATE" PRICE	NO	UPDATE YOUR FIRE EXTINGUISHING CAPABILITY—ASK FOR "TRADE-IN UPDATE" PRICE	UPDATE YOUR FIRE EXTINGUISHING CAPABILITY—ASK FOR "TRADE-IN UPDATE" PRICE	YES	YES	YES	YES	YES
CLASS C FIRES ELECTRICAL EQUIPMENT 	NO		NO			YES	YES	YES	YES	YES
CLASS D FIRES COMBUSTIBLE METALS 	SPECIAL EXTINGUISHING AGENTS APPROVED BY RECOGNIZED TESTING LABORATORIES									
METHOD OF OPERATION	PULL PIN-SQUEEZE HANDLE	OBSOLETE	PUMP HANDLE	OBSOLETE	OBSOLETE	PULL PIN-SQUEEZE LEVER	RUPTURE CARTRIDGE-SQUEEZE LEVER	PULL PIN-SQUEEZE HANDLE	PULL PIN-SQUEEZE HANDLE	RUPTURE CARTRIDGE-SQUEEZE LEVER
RANGE	30' - 40'	UPDATE YOUR FIRE EXTINGUISHING CAPABILITY—ASK FOR "TRADE-IN UPDATE" PRICE	30' - 40'	UPDATE YOUR FIRE EXTINGUISHING CAPABILITY—ASK FOR "TRADE-IN UPDATE" PRICE	UPDATE YOUR FIRE EXTINGUISHING CAPABILITY—ASK FOR "TRADE-IN UPDATE" PRICE	3' - 8'	5' - 20'	5' - 20'	5' - 20'	5' - 20'
MAINTENANCE	CHECK AIR PRESSURE GAUGE MONTHLY	UPDATE YOUR FIRE EXTINGUISHING CAPABILITY—ASK FOR "TRADE-IN UPDATE" PRICE	DISCHARGE AND FILL WITH WATER ANNUALLY	UPDATE YOUR FIRE EXTINGUISHING CAPABILITY—ASK FOR "TRADE-IN UPDATE" PRICE	UPDATE YOUR FIRE EXTINGUISHING CAPABILITY—ASK FOR "TRADE-IN UPDATE" PRICE	WEIGH SEMI-ANNUALLY	WEIGH GAS CARTRIDGE-CHECK CONDITION OF DRY CHEMICAL ANNUALLY	CHECK PRESSURE GAUGE AND CONDITION OF DRY CHEMICAL ANNUALLY	CHECK PRESSURE GAUGE AND CONDITION OF DRY CHEMICAL ANNUALLY	WEIGH GAS CARTRIDGE-CHECK CONDITION OF DRY CHEMICAL ANNUALLY

NOTES:

Class D Fires - In hot metal areas which may utilize magnesium, titanium, zirconium & sodium must provide Type D extinguishers or D rated dry chemical available for use on metal fires.

175

It is important that the correct extinguisher is used on the proper class of fire.

C. 175

PERSONAL PROTECTION

1. HEAD
 - A. Confine long hair so that it is not exposed to machinery.
 - B. Provide hard hat where appropriate.
2. EYE-FACE
 - A. Require the wearing of appropriate safety equipment where there is a danger of injury. (See ANSI Eye Protection Chart)
3. RESPIRATORY
 - A. Provide respirators for student use where harmful dusts or fumes exist. (See Respiratory guideline)
 - B. Ensure adequate ventilation for dusts, fumes and vapors.
4. BODY PROTECTION
 - A. Prohibit the wearing of loose clothing in the laboratory.
 - B. Require students to remove rings and other jewelry while working in the laboratory.
 - C. Provide leggings and foot protection, armbands, gloves, aprons, and shields when working with molten material.
 - D. Make certain that the appropriate protective clothing is used when handling harsh materials that would cause chemical burns or lacerations.
5. HEARING
 - A. Where noise levels are excessive over long periods of time, ear protection should be worn. (See Permissible Noise Exposure Table)
 - B. Engineering solutions should be sought out to remedy excessive noise problems.
 - C. Monitor noise levels with a Type 2A noise level meter.
6. PERSONNEL PROTECTION CAUTIONS
 - A. Determine the physical defects and limitations of all students so that they will not be assigned tasks detrimental to their health or physical condition.

- B. Substitute and alternate protective fabric for asbestos garments. Asbestos is detrimental to the health of the wearer and should be avoided.

EYE PROTECTION

1. The law of the Commonwealth of Pennsylvania requires that eye protection programs be developed and implemented in all areas where there are activities potentially hazardous to the eye. (See "Act No. 116"). A procedure for adaptation for school districts is as follows:
 - A. All administrators and teachers shall assess the eye exposures for which they are responsible, and recommend the appropriate protection. This recommendation shall protect students, staff members, and visitors. (See Selection Chart-American National Standards Institute Z87.1-1968)
 - B. It is the responsibility of industrial arts instructors to see that eye protection is worn AT ALL TIMES in those areas that have been identified as exposure areas.
 - C. Eye protection shall be supplied and maintained by the school district and loaned without cost to students, staff members and visitors.
 - D. The physical inspection and periodic review of the eye safety program shall be the responsibility of a designated school district administrator for insuring the effectiveness of the eye protection program.

Reference is also made to "American National Standard Practice for Occupational and Educational Eye and Face Protection", ANSI Z87.1-1968.

This program shall be rigidly enforced and monitored by all concerned. There should be no deviation from the program once it is accepted and put into use.

2. Students who require corrective lenses shall be encouraged to obtain prescription safety glasses. When plain prescription glasses are worn, the student should be required also to wear an appropriate cover goggle.

Caution: Most shatter-resistant glasses do not meet the standard of ANSI and many "safety glasses" also fail the tests and design features listed.

Contact lenses, even though covered by approved eye protection, shall not be worn in a laboratory during which an activity involving the caustic

liquids or gases is taking place. If contact lenses are medically necessary and corrective glasses cannot be substituted for the lenses, a physician's statement will be required.

3. Storage and sanitation facilities shall be provided within the classroom for all eye protection. School districts have found that they had better eye protection programs when individual glasses had been provided for each student enrolled in the industrial arts class.

Good eye protection devices require clean lenses. Lenses shall be cleaned daily.

Fitted or scratched lenses shatter easily and impair vision and should be replaced. If a protective device is to be worn by more than one student, it will require a means of disinfection. The most effective method of disinfecting eye protective equipment is:

- A. Use ultra-violet sanitation cabinet.
- B. Thoroughly clean with soap and warm water periodically.
- C. Carefully dry with non-abrasive tissue.

4. School officials who are charged with the purchase of eye protection equipment should be aware of the various accident classifications and purchase the appropriate eye protection for each exposure. The following four groups represent the classification of all eye accidents:

- A. Potential Hazards From Impact:

Possibly the greatest danger to the eyes is their accidental collision with flying objects. Chips from the chipper hammer or the metal working tool, the waste particles from grinding or woodworking, a broken tool or grinding wheel or an improperly driven nail are all eye exposures that must be protected against. Plastic frame safety glasses with side shields afford maximum eye protection against impact damage.

- B. Potential Hazards from Chemical Splash:

Protection is needed that absolutely seals the eye against any possible entry. For these conditions, flexible vinyl jumbo plate goggles with splash-proof indirect ventilators should be worn.

- C. Potential Hazards From Dust:

As above. Where extreme dust hazards exist, plastic frame flexible goggles are more desirable. Safety glasses with side shields are also recommended.

D. Potential Hazards From Light Ray and Glare:

1. The light rays cast from welding and cutting operations can be highly injurious to unprotected eyes. Heat treating, metal pouring, steel and glass furnaces and laser beams are other sources of glare.
2. In gas welding, cup type welding goggles with green filter lenses are most commonly used.
3. For electric welding, helmets are necessary to protect the head and eyes from infra-red and ultra-violet radiation burns, hot metals, chips and flying sparks.
4. Contact lenses present specific hazards in the laboratory setting. The use of contact lenses should be discouraged in the lab.
5. Photocromatic and phototropic (photosun-photogray) lenses may not be worn as protective eyewear where hazardous infra-red or ultra-violet radiation is present.

USA STANDARD PRACTICE FOR OCCUPATIONAL
AND EDUCATIONAL EYE AND FACE PROTECTION

Selection Chart

Recommended Eye and Face Protectors for Use in Industry, Schools, and Colleges

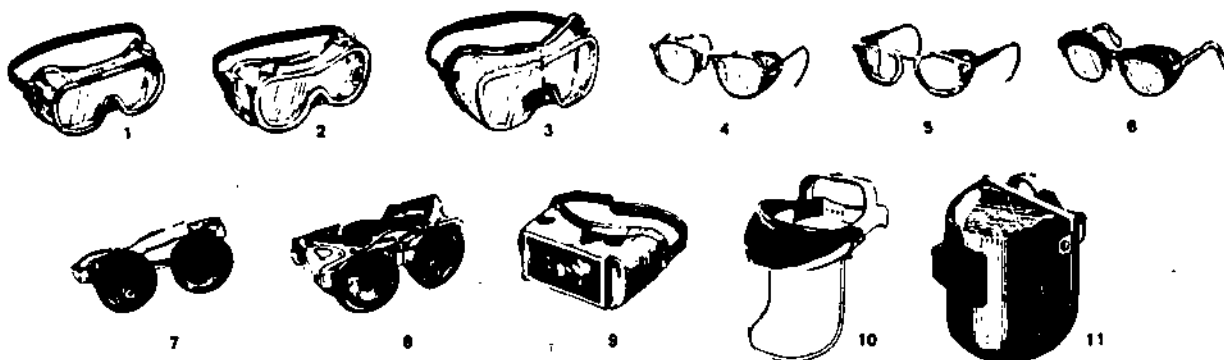

- 1. GOGGLES, Flexible Fitting, Regular Ventilation
- 2. GOGGLES, Flexible Fitting, Hooded Ventilation
- 3. GOGGLES, Cushioned Fitting, Rigid Body
- *4. SPECTACLES, Metal Frame, with Sideshields
- *5. SPECTACLES, Plastic Frame, with Sideshields
- *6. SPECTACLES, Metal-Plastic Frame, with Sideshields
- ** 7. WELDING GOGGLES, Eyecup Type, Tinted Lenses (Illustrated)
- 7A. CHIPPING GOGGLES, Eyecup Type, Clear Safety Lenses (Not Illustrated)
- ** 8. WELDING GOGGLES, Coverspec Type Tinted Lenses (Illustrated)
- 8A. CHIPPING GOGGLES, Coverspec Type, Clear Safety Lenses (Not Illustrated)
- ** 9. WELDING GOGGLES, Coverspec Type, Tinted Plate Lens
- 10. FACE SHIELD (Available with Plastic or Mesh Window)
- **11. WELDING HELMETS

*Non-sideshield spectacles are available for limited hazard use requiring only frontal protection.
**See appendix chart "Selection of Shade Numbers for Welding Filters."

APPLICATIONS		
OPERATION	HAZARDS	RECOMMENDED PROTECTORS: <small>Bold Type Numbers Signify Preferred Protection</small>
ACETYLENE-BURNING ACETYLENE-CUTTING ACETYLENE-WELDING	SPARKS, HARMFUL RAYS, MOLTEN METAL, FLYING PARTICLES	7, 8, 9
CHEMICAL HANDLING	SPLASH, ACID BURNS, FUMES	2, 10 (For severe exposure add 10 over 2)
CHIPPING	FLYING PARTICLES	1, 3, 4, 5, 6, 7A, 8A
ELECTRIC (ARC) WELDING	SPARKS, INTENSE RAYS, MOLTEN METAL	9, 11 (11 in combination with 4, 5, 6, in tinted lenses, advisable)
FURNACE OPERATIONS	GLARE HEAT, MOLTEN METAL	7, 8, 9 (For severe exposure add 10)
GRINDING-LIGHT	FLYING PARTICLES	1, 3, 4, 5, 6, 10
GRINDING-HEAVY	FLYING PARTICLES	1, 3, 7A, 8A (For severe exposure add 10)
LABORATORY	CHEMICAL SPLASH, GLASS BREAKAGE	2 (10 when in combination with 4, 5, 6)
MACHINING	FLYING PARTICLES	1, 3, 4, 5, 6, 10
MOLTEN METALS	HEAT, GLARE, SPARKS, SPLASH	7, 8 (10 in combination with 4, 5, 6, in tinted lenses)
SPOT WELDING	FLYING PARTICLES, SPARKS	1, 3, 4, 5, 6, 10

LESSON PLAN FOR EYE SAFETY IN SCHOOL SHOP AND LAB

- SPECIFIC AIM:** To help students understand the need for eye safety equipment in the classroom.
- GENERAL AIM:** ~~This lesson is intended as a general guide~~ for the shop or lab instructor at the very beginning of the course. It should be useful in making certain that every student becomes aware of potentially hazardous power equipment, tools, processes and chemicals in his vicinity, and that he thereby learns and follows good eye safety practices.
- CONTENT:** The class is expected to learn the necessity of wearing eye protection through the medium of lecture and demonstration and through visual aids.
- EQUIPMENT:** Safety glasses and goggles (also face shields and welding helmets where necessary.) Safety glass monitor. Visual aids (see below) and projection equipment. Eye safety posters and booklets.
- PROCEDURE:**
- Introduction - Point out the power tools, machines, chemicals and processes that are potentially hazardous to the eyes in case of accident. Explain how eye injuries from such mishaps can be avoided through the use of proper eye protection. Show the actual eye safety products that provide this protection.
- Fit and Cleaning - Explain how various eye protection is adjusted for proper fit and comfort. Also, demonstrate the proper techniques for cleaning eye protection and discuss the need for clean, scratch-free glasses.
- Visual Aids - Show one of the many fine 16 mm motion pictures developed for classroom use, such as:
- "The Windows of Your Soul" (28 min.)
 - "The Smartest Kid in Town" (20 min.)
 - "It's Up to You" (12 min.)
 - "Everything To Lose" (20 min.)
 - "Expedite School Eye Safety" (12 min.)
 - "Don't Push Your Luck"
- These films, generally in color, have been prepared by such interested organizations as the National Society for the Prevention of Blindness and the National Safety Council. They are available for purchase or for rent.

DISCUSSION
PERIOD:

Tell the class about proper maintenance of eye protection products, including storage and sanitation. Here show the safety glass monitor and start assigning glasses and storage positions.

Explain safety rules of this classroom and appoint a student "Safety Director" to help with enforcement.

Follow with questions and answers.

HB 159

Providing for the use of eye protective devices by persons engaged in hazardous activities or exposed to known dangers in schools, colleges and universities.

The General Assembly of the Commonwealth of Pennsylvania hereby enacts as follows:

Section 1. Every teacher, student, visitor, spectator, and every other person in any shop or laboratory in public or private schools, colleges and universities who is engaged in or is within the area of known danger created by

(1) the use of hot liquids, solids or gases, or caustic or explosive materials, or

(2) the milling, sawing, turning, shaping, cutting, grinding or stamping of solid materials, or

(3) the tempering, heat treatment or kiln firing of metals and other materials, or

(4) gas or electric welding, or

(5) the repairing or servicing of vehicles,

shall wear industrial quality eye protective devices at all times while engaged in such activities or exposed to such known dangers.

Section 2. Schools, colleges and universities shall have the power to receive Federal, State and local moneys and to expend the same to provide such devices and shall furnish such devices to all visitors and spectators and all other persons required under the provisions of this act to wear them.

Section 3. Enforcement of this act shall be in accordance with standards, rules and regulations promulgated by the State Board of Education.

Section 4. For the purposes of this act, "industrial quality eye protective devices" mean devices meeting the standards of the American Standard Safety Code for Head, Eye and Respiratory Protection, Z2.1-1959, promulgated by the American Standards Association, Incorporated.

Section 5. This act shall take effect immediately.

APPROVED—The 19th day of July, A. D. 1965.

WILLIAM W. SCRANTON

The foregoing is a true and correct copy of Act of the General Assembly No. 116.



Secretary of the Commonwealth.

HEARING CONSERVATION PROGRAMS

The OSHA noise regulations are brief - a little over one column - but far-reaching. Basically, there are two sections: the first sets the maximum levels of noise to which a person may be exposed; the second section explains what action must be taken if these noise levels are exceeded.

The key part of the OSHA standard is the Permissible Noise Exposure Table. It sets the amount of time that a person may be exposed to various levels of sound, as measured in decibels or dB.

The basic standard permits a person to work eight hours a day on a job where steady-state noise does not exceed 90 dB as measured on the A-scale of a standard sound level meter at slow response. Many people believe that protection should start at 85dB (A). For this reason OSHA decided in August 1973 to make Hearing Conservation Programs (medical surveillance) mandatory whenever steady-state noise exposure exceeds 85dB. For any period of exposure to impulsive or impact noise a 140dB peak reading may not be exceeded.

Permissible Noise Exposure Table

Duration per day, hours:	Sound level dba
8	90
6	92
4	95
3	97
2	100
1½	102
1	105
½	110
¼	115

In many situations, the sound intensity exceeds the levels set by the program. Action involves three basic steps:

1. Reducing noise at its source through administrative and engineering controls.
2. Provide hearing protection.
3. Carrying out a program of hearing conservation.

The choice of hearing protective device should be left to the wearer. Remember, "the best hearing protector is the one that is worn."

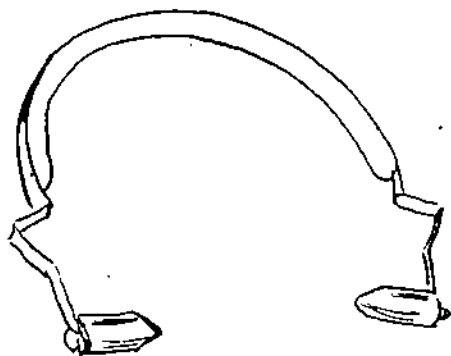

Sound Ban - Air cushioned pads provide a seal at the entrance to the ear canal.



Muff - covers ear completely.



Plugs of the disposable type provide hygienic effective protection.

CHART OF SELECTED NOISE SOURCES

SPEAKING EFFORT REQUIRED AND NOISE SOURCES	SOUND LEVEL Db (Decibels)	MAXIMUM EXPOSURE PER DAY								
		8 hrs	7 hrs	6 hrs	5 hrs	4 hrs	3 hrs	2 hrs	1 hrs	30 min
Threshold of pain	120									
Nearly impossible to communicate by voice	115									
riveting a steel tank										
sand blasting										
Very difficult to communicate by voice	110									
drills, steam shovels operating a truck riveting machines										
Shout into other person's ear	105									
rock and roll band circular saw										
Shout at 1/2 foot	100									
can manufacturing plant portable grinder										
Shout at 1 foot	95									
power lawn mower										
Normal voice at 1/2 foot	90									
portable sander; welding equip't										
Normal voice at 1 foot	85									
Normal voice at 1 1/2 feet inside a sports car at 50 mph	80									
Normal voice at 2 feet	75									
Normal voice at 2 1/2 feet	70									

RESPIRATORY PROTECTION

1. It is vital that appropriate respiratory devices be provided to a student who is exposed to hazardous substances.
 - A. Consult the respiratory protection guideline.
 - B. Request assistance from a local Safety Council member when in doubt as to the respirator which is appropriate, or when doubt is present as to the concentrations present and the sufficiency of a standard type respirator.
2. Clean respirators must be provided, especially if devices are used by several students.
3. Ventilation of dust, fumes and vapors should be undertaken when possible.
4. If any student suffers from a respiratory illness, his doctor should be consulted to determine if that student can utilize a respirator for protective purposes, or be involved in activities where exposure is a possibility.

BACK STRAINS FOR PROPER LIFTING

Back strains due to improper lifting probable cause more lost time from work than any one single type of injury.



Accident in manual handling of materials are mainly the result of unsafe working habits--improper listing, carrying too heavy a load, incorrect gripping, and failiny to wear personal protective equipment.

Training in proper methods of lifting is mandatory in any safety program. Good lifting practices can prevent many back strains.

Improper lifting could injure you for life. Study the next page to learn the proper lifting method.

RESPIRATOR PROTECTION SHOULD BE CAREFULLY SELECTED FOR EACH SPECIFIC APPLICATION, AND SHOULD NOT BE WORN IN ATMOSPHERES IMMEDIATELY DANGEROUS TO LIFE OR HEALTH, OR IN ATMOSPHERES CONTAINING LESS THAN 19.5% OXYGEN. WEARER SHALL BE FITTED ACCORDING TO THE INSTRUCTIONS SUPPLIED BY THE MANUFACTURER, AND RESPIRATORS MAINTAINED ACCORDINGLY.

RESPIRATORY PROTECTION
GUIDELINE

WORK AREA	HAZARD	NIOSH CERTIFICATION		RESPIRATOR TYPE
WOOD WORKING	NUISANCE DUST	TC-21C DISPOSABLE		APPROVED FOR PNEUMONCONIOSIS AND FIBROSIS DUSTS
METAL GRINDING CERAMIC POLISHING	NUISANCE AND TOXIC DUSTS	TC-21C TYPE WITH DUST REPLACEABLE FILTER		APPROVED FOR DUSTS AND MIST
SPRAY PAINTING	ORGANIC VAPORS PAINT SPRAYS PARTICULATES	TC-25C CHEMICAL CARTRIDGE AND REPLACEABLE FILTER COMBINATION		APPROVED FOR ORGANIC VAPORS, DUSTS, MIST, PAINT, LACQUER AND ENAMEL MIST
PRINT SHOP	ORGANIC VAPORS AND TOXIC	TC-23C CHEMICAL CARTRIDGE AND REPLACEABLE FILTER COMBINATION		APPROVED FOR ORGANIC VAPORS AND/OR DUSTS MISTS
DRAFTING	AMMONIA VAPORS	TC-23C CHEMICAL CARTRIDGE TYPE		APPROVED FOR AMMONIA VAPORS
JEWELRY ETCHING AND CLEANING	ACID GASES METAL FUMES	TC-25C CHEMICAL CARTRIDGE COMBINATION TYPE		APPROVED FOR ACID GASES OR METAL FUMES
MELT SHOPS WELDING SHOPS	BRASS, IRON AND OTHER METAL FUMES, AGENTS	TC-21C REPLACEABLE DUST MIST - FUME FILTER		APPROVED FOR METAL FUMES
AGRICULTURE	PESTICIDES	TC-25C CHEMICAL CARTRIDGE AND REPLACEABLE FILTER COMBINATION		APPROVED FOR PESTICIDES

1

First, size up the load - do not attempt to lift it alone if you have doubt in your ability to do so.

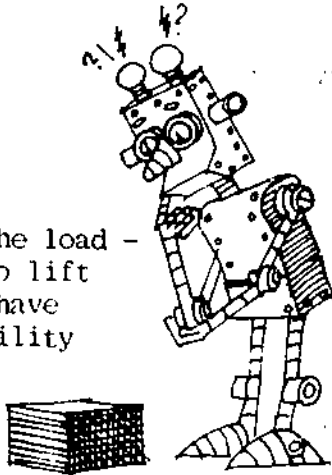

2

Make sure that your footing is secure. One foot may be forward of the other to attain good balance.

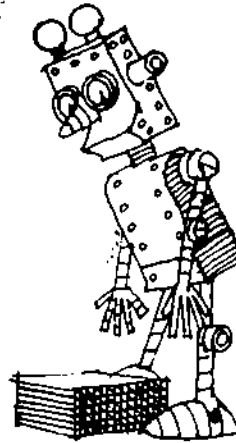

3

Bend the knees and squat (don't stoop) keeping the back as nearly vertical as possible. Spread the knees or lower one knee to get closer to the object.

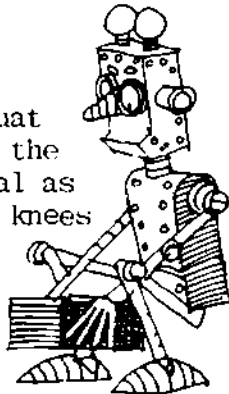

4

Now start pushing up with your legs. Keep the load close to your body as you come up.

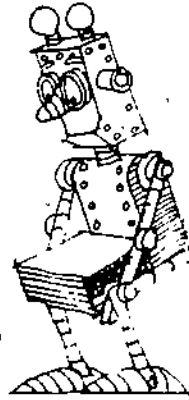

5

Lift the object to the carrying position. Do not twist the body. Turn your body by changing the position of the feet.

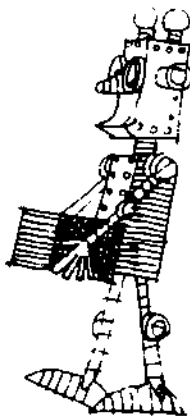

6

In lowering the load to the floor, bend the knees. Keep the back straight with the load close to the body, lowering the load with the arm and leg muscles.

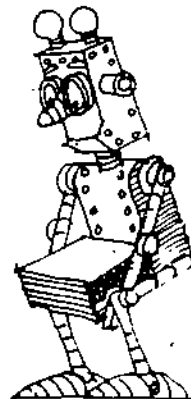

FACILITY PLANNING

When planning or equipping an industrial arts facility, regardless of the laboratory, or subject discipline involved, there are a great many situations and details which should be justified as the planning progresses. Unfortunately, in most cases, safety becomes an "extra-curricular" consideration or, at the very least, one of the last check points considered.

In the process of writing specifications for equipment and developing an actual floor plan, the following factors are normally considered by the planner or the spec writer:

1. Flow of materials
2. Flow of students
3. Tool & equipment arrangement
4. Electrical and other utilities
5. Dust collection
6. Color
7. Lighting
8. Storage
9. Costs
10. Ventilation
11. Noise
12. Tool & equipment specifications

Considering the moral, financial, and legal interests in safety--in school, industry, home, and in every facet of human endeavor, it is almost naive not to give safety a dominant and controlling role in planning. Regardless of this, safety seldom appears as a major heading.

A good mental safety check might be to ask "is it safe?", then add the phrase "pertinent to that particular plan consideration, or tool operation":

1. Is it safe concerning the flow of material?
2. Is it safe concerning the flow of students?
3. Is it safe concerning the operator?

4. Is it safe concerning nearby operations?
5. Is it mechanically safe?
6. Is it safe for inexperienced operators?
7. Is it safe for ripping?
8. Does ventilation and color contribute to safety?

In most cases, design or mechanical safety considerations for equipment and for the operation of equipment are specifically spelled out by law, by directives from various governing bodies, or by an industrial arts supervisor. Although complying with OSHA requirements, state requirements, the National Electrical Code, National Safety Council suggestions, UL requirements, in addition to suggestions by various publishers, associations, and manufacturers--we still get back to the original premise "is it safe?", or more specifically, "is it really safe?".

Considering the school district, the type of students, the number in the class, the specific subject discipline, the physical configuration of the shop or laboratory and the instructor's personal desires, it is quite possible after all of the legal and suggested factors are considered, the practical and expected results may fall short. This is, of course, due to the fact that most rules, directives, regulations, or even laws are made for the majority of cases. It is quite probable that there will be situations not covered by either general or specific rules. In this case, the instructor should augment these requirements with additional rules based on the situation and past personal, experience.

The placement of machines and equipment in given work areas is critical and should allow for the normal flow of materials through the operational process. There should be a minimum of cross traffic of both material and/or students.

Where hazards exist around a machine, the machine should be placed so students in the area are not in the line of danger. The hazard area should be indicated by safety zones--painted on the floor. Traffic aisles should also be designated by painted lines on the floor similar to those used in industry. The aisles should provide adequate travel space between benches, machines, and in areas in front of tool panels, storage lockers or other areas where students may either congregate or be working. Special consideration should be given to areas where molten metal, welding, heat treating or other potentially dangerous operations may be in process.

Non-skid surfaces can be applied to the floor in machine operating zones to minimize the danger of slipping. Large assembly areas should be available in construction or manufacturing laboratories.

All electrical considerations must comply with not only the National Electrical Code, but also specific regulations set up by the state for all

school buildings. Stationary machines, regardless of the type of power, should all be equipped with magnetic starters, giving overload, low-voltage, and no voltage protection. All portable equipment should have a 3-wire conductor or be "double insulated." All wall plugs or receptacles must be grounded and should be conveniently located to eliminate the use of extension cords whenever possible. The type of current should also be indicated if other than single phase, 115 volt is available from that receptacle. Pull down, self-retracting or similar type of lines could be specified for "center-of-the-shop" locations. In addition to a locking central control panel for the laboratory or shop, "panic buttons" should be located in strategic areas which could be used to immediately shut off all power except to the light fixtures. Other considerations such as the location of gas or air lines, the colors used in the shop not only for the walls and ceiling, but also for the equipment, lighting, and certainly dust collection should be analyzed and the safest system or method recommended. The word safety as far as machinery is concerned should not just indicate compliance with existing laws or regulations. It should go much farther than the general concept of merely providing guards over belts and pulleys--and/or hoods over revolving blades or cutters. Some investigation should be done concerning the original design of the machine not only in the normal mechanical and electrical aspects, but serious consideration should also be given to the machines' operation by inexperienced or student operators. The instructor may have to add additional safety equipment beyond the manufacturers recommendation or beyond the legal considerations to satisfy his/her own opinion concerning a "safe machine" or safety in operation. The following space recommendation table is from the 1974 Guide To Preparing Educational Specifications For Secondary Industrial Arts Facilities, published by the American Council of Industrial Arts Supervisors.

RECOMMENDATIONS FOR TRADITIONAL INDUSTRIAL ARTS COURSES

	MINIMUM	ADEQUATE	DESIRED
GENERAL	80	100	125
CRAFTS	75	100	125
METALS	75	100	125
DRAFTING	40	50	60
CERAMICS	60	70	80
ELECTRICITY	60	70	80
WOODS	80	100	125
POWER MECHANICS	75	80	100
PLASTICS	60	70	80
GRAPHIC ARTS	75	80	100

(Figures in square feet per student)

These space suggestions do not include storage areas, finishing rooms, planning areas or other similar allied areas.

More detailed space allocations for non-traditional Industrial Arts areas are listed in this ACIAS publication and in the "Guide To Equipping Industrial Arts Facilities" published by the American Industrial Arts Association.

GENERALLY ACCEPTED STANDARDS OR PRACTICES:

Aisles

Walkways or aisles should be a minimum of three feet, preferably four feet.

Machines and Equipment

All units must comply with existing state and Federal laws as a minimum requirement and all OSHA requirements.

Machines such as table saws, jointers, and planers, which are capable of violently kicking the stock back, must be arranged so that the stock will not be thrown into areas where other students will be working.

Also, space allocated for each machine should be sufficient to allow safe and convenient movement around it while it is being used.

Ventilation

All laboratories should have a complete air change every ten minutes - six times per hour - for adequate ventilation. Special consideration through the use of hoods should be given to areas or operations producing excess fumes, heat or dust.

Lighting

Laboratory areas require 70 foot candles, drafting areas 100 foot candles. Additional lighting is often necessary through the use of flexible or adjustable lamp attachments on specific machines or in hazardous areas.

Storage

Additional ventilation is needed for bulk storage of compressed gas. At least 20 feet of space or a fire resistant barrier is required between stored oxygen and tanks. The finishing room or area must have metal cabinets for storing paint and other finishing materials. Metal waste cans must be used for discarded rags and other similar materials.

Special Needs

In areas where hazardous chemicals are used eyewash fountains and/or other appropriate shower facilities should be provided. Fire extinguishers of the correct type should be strategically located. A basic first aid kit should also be a standard part of the laboratory equipment, and some provision made to keep it stocked with fresh supplies.

Noise

Specific types of laboratories produce a higher noise level than others. This level, in conjunction with the time involved, must be kept below permissible OSHA sound levels.

<u>DURATION PER DAY</u>	<u>SOUND LEVEL</u>
(HOURS)	dba
8	90
8	92
4	95
3	97
2	100
1½	102
1	105
½	110
¼ or less	115

This can be accomplished through the use of sharp tooling; proper maintenance and correct alignment of machinery; the use of energy and noise absorbing materials; or the substitution of quieter procedures or equipment. Personal protection such as ear plugs or ear muffs are necessary when the noise level and the time of exposure exceed OSHA standards. If a normal speaking voice cannot be understood from two feet away, the noise level is probably excessive.

Dust

Control or collection of dust is necessary, particularly in the woodworking area. This can be accomplished by the installation of a dust collection system or by individual dust collectors on specific tools. Abrasive finishing machines, both portable and stationary, are most critical. General cleanliness in the laboratory can contribute greatly to dirt and dust control. If the laboratory is to be air conditioned a central dust collection system is almost mandatory.

Color

Colors should be used to create a pleasant work area (attitude) and to reduce glare. Light pastels are best for walls, partitions, and ceiling areas. There is no agreed standard for "color coding" machines or equipment, but different colors or shades of the same color is an excellent way to differentiate between various parts. This method can also be used to emphasize a hazardous area, point of operation or nip

point, etc. Most equipment color suggestions would follow this basic ASA (American Standards Association) ZR53 color system:

- . Basic unit - Gray or green (by tradition)
- . Parts which may cut, crush, or shock (guards) - Orange
- . Parts which move-or project (warning) - Yellow (or black & yellow stripes)
- . "Stop" buttons or switches - Red
- . Unit under repair (sign) - Blue

Other color suggestions:

- . Fire alarm boxes, exit signs, fire extinguishers, barricade lights-danger signs - Red
- . First aid kits-stretcher equipment - safety signs - Green
- . Traffic zone markings - Black, white (or black and white)
- . Housekeeping markings - Yellow, black & yellow

The personal system you choose must be standard throughout your laboratory. New equipment should be touched up or painted to match existing equipment.

Safety consideration is a critical requirement of facility planning and can "pre-solve" many future safety problems.

SAFETY SIGNS

Before you select a sign determine what you want it to do. Signs can do such things as:

1. Warn of dangerous situations.
2. Give instructions.
3. Point out the location of something.

Signs can help provide a safe and healthful working laboratory when you use the right sign for the right job.

Signs should be short and descriptive so they can be quickly and easily understood. The heading and the color of a sign help determine its effectiveness. These headings have been standardized by the OSHA code. Examples of them are listed on the next page.

Signs that warn of real or potential hazards must be visible to all persons and promptly removed or covered when the hazard no longer exists. Signs should be posted for maximum visibility, usually at eye level.

SAFETY SIGN GUIDE



DANGER — White letters on red oval surrounded by a rectangular black field. "Danger signs should be used only where an immediate hazard exists. There shall be no variation in the type of design of signs posted to warn of specific dangers and radiation hazards." OSHA 1910.145



NOTICE — White letters on blue field. "Blue shall be the standard color for informational signs. It may be used as the background color for the complete signs or as a panel at the top of such 'Notice' signs which have a white background." OSHA 1910.145



SAFETY FIRST — White letters on green field. "Safety instruction signs shall be used where there is a need for general instructions and suggestions relative to safety measures." OSHA 1910.145



CAUTION — Yellow letters on black field. "Caution signs shall be used only to warn against potential hazards or to caution against unsafe practices." OSHA 1910.145



BE CAREFUL — White letters on green field. A safety reminder advising your personnel re: hazards and safety practices.



THINK — White letters on green field. Helps remind personnel to stay alert.

SAFETY SIGNS

OSHA STATUTE/SUBJECT	IDENTIFICATION REQUIREMENT	OSHA STATUTE/SUBJECT	IDENTIFICATION REQUIREMENT
FIRE CONTROL		EXITS and ENTRANCES	
1910.157 PORTABLE FIRE EXTINGUISHERS	LOCATION OF EXTINGUISHERS SHALL BE CONSPICUOUSLY MARKED.	1910.36 (5) EXIT MARKING	IDENTIFY EXITS.
1910.157 (3) FIRE EXTINGUISHERS	DIRECTIONS TO NEAREST FIRE EXTINGUISHER MUST BE MARKED.	1910.36 (5) NO EXIT MARKING	IDENTIFY DOORS WHICH ARE NOT EXITS.
1910.158 (b) FIRE HOSE	FIRE HOSE MUST BE MARKED.	1910.37 (0) DIRECTION ARROWS	SIGNS AND ARROWS INDICATING THE PATH
1910.38 FIRE EXIT	FIRE DOOR MUST BE MARKED TO INSURE CLEAR PATH.	1910.68 (7) VISITOR WARNING	"AUTHORIZED PERSONNEL ONLY"
1910.157 PORTABLE FIRE EXTINGUISHERS	MAINTENANCE AND RECHARGE DATE TAGS FOR FIRE EXTINGUISHERS	STORAGE	
MISCELLANEOUS		1910.109 EXPLOSIVES/PROPERTY MARKING	SIGN--"EXPLOSIVES --KEEP OFF"
1910.25 LADDERS	DEFECTIVE LADDERS MUST BE TAGGED "DO NOT USE"	1910.1000 TO 1910.1017 TOXIC AND HAZARDOUS SUBSTANCES	POSTING OF WARNING SIGNS AND LABELING OF HAZARDOUS MATERIALS
1910.94 VENTILATION	MARKING RESPIRATOR STORAGE COMPARTMENTS.	1910.106 FLAMMABLE AND COMBUSTIBLE LIQUIDS STORAGE	MARK CABINET "FLAMMABLE--KEEP FIRE AWAY"
1910.142 IDENTIFY TOILET FACILITIES	DISTINCTLY MARK "MEN," "WOMEN."	1910.105 FLAMMABLE AND COMBUSTIBLE LIQUIDS STORAGE	SIGN IN STORAGE LOCATION--"DANGER NO SMOKING"
1910.145 STANDARDS FOR ACCIDENT PREVENTION SIGNS	VARIOUS AND MISCELLANEOUS FOR DANGER, CAUTION AND NOTICE MARKING.		
1910.145 ACCIDENT PREVENTION TAGS	TEMPORARY WARNINGS OF HAZARDOUS CONDITIONS		
ELECTROMECHANICAL			
1910.308 ELECTRICAL STANDARDS	ENTRANCE TO ROOM ATTENDING EXPOSED ELECTRICAL PARTS SHALL BE MARKED		
1910.308 ELECTRICAL STANDARDS	POST TEMPORARY LOCKOUT TAG ON SWITCHES AND EQUIPMENT TO BE CLOSED DOWN WHILE UNDERGOING REPAIR.		
1910.308 ELECTRICAL STANDARDS	IDENTIFY SWITCH BOXES AND SWITCHES WITH VOLTAGE; IDENTIFY "DANGER-HIGH VOLTAGE"		

14.08

PENNSYLVANIA SCHOOL INDUSTRIAL ARTS SAFETY INSPECTION CHECK LIST

Prepared by the Pennsylvania Department of Education
and the Industrial Arts Association of Pennsylvania

School _____ Laboratory _____ Date _____

Instructor _____ Inspection Team _____

PURPOSE

A safe environment is an essential part of the industrial arts safety education program. The safe environment will exist only if hazards are discovered and corrected through regular and frequent inspections by school personnel—administrators, safety coordinators, teachers and students. Safety inspections are to determine if everything is satisfactory.

A safety inspection checklist for industrial education is an objective tool for helping improve working conditions in the area where used. Using a safety check list for the inspection has some advantages over other methods of safety inspection. This list is intended to accomplish the following:

1. Inform, educate and remind people of what to look at.
2. Train personnel to be observant and aware of their environment.
3. Provide a source of feedback information to teachers and administrators. This allows them to determine the effectiveness of their safety program and training.
4. Provide a record of safety items and safety activity.

The Pennsylvania School Industrial Arts Safety Inspection Check List is recommended for all industrial arts laboratory inspections.

INSTRUCTIONS FOR USE

1. A safety inspection team should complete the check list for each industrial arts laboratory. (The building principal should be a member of the team.)
2. The inspection team may arrange for additional assistance from outside agencies for the regular safety inspections.
3. As a minimum, safety inspections should be made at the beginning of every school term or semester. More frequent inspections may be advisable.
4. Inspections should be planned in advance, preferably for times when students will be using the facility.
5. The current inspection report should be compared with previous reports and records to determine progress. The report should be studied in terms of accident situations so that special attention can be given to these conditions and locations which are accident producers.
6. In all cases where unsatisfactory responses are indicated it is important that corrective actions be noted and copies forwarded to the proper authorities.
7. Each unsafe condition should be corrected as soon as possible in accordance with accepted local procedures.
8. A conference of the inspection team and the teacher should be held shortly following the inspection.

CHECKING PROCEDURE

Draw a circle around the appropriate letters, using the following code. Respond to all items:

- S — Satisfactory (needs no attention)
U — Unsatisfactory (needs immediate attention)
NA — Not applicable

Recommendations should be made in all cases where a "U" is circled. Space is provided at the end of the form for such comments. Designate the items covered by the recommendations, using the section letter and number applicable (e.g. B-2).

202

A. SCHOOL ADMINISTRATION

1. The school principal and school safety officer visit all laboratories to check for hazardous conditions and to make provisions for corrections. S U NA
2. The school principal requires that standardized written reports on hazardous conditions be submitted and distributed to the proper individuals to assure corrective action S U NA
3. A written procedure has been established for reporting defective equipment immediately to assure prompt repair S U NA
4. The school principal keeps records of all inspections and these records are readily available for reference S U NA
5. The school district has defined "an accident" and has available employee and student accident reporting forms which fulfill the state statistical requirements S U NA
6. All accidents are promptly reported and analyzed. Immediate steps are undertaken to correct causes of accidents, and copies of all reports are kept in a school file until it is determined they are not longer necessary. . . . S U NA
7. The school has readily available all necessary information in order to reach parents or guardians in case of emergency. S U NA
8. The school has an effective standardized district safety policy S U NA
9. The school has an effective policy and procedure to follow in case of accident S U NA
10. The school has a policy and procedure for the administration of first aid S U NA
11. The instructor is notified of all student disabilities (physical and mental) S U NA
12. The instructor has direct communication with the school nurse and outside telephone lines available S U NA
13. First aid personnel or nurse is available at all times. S U NA
14. The school principal accepts the responsibility for keeping class sizes appropriate for activities, student age, facility size, and the number of work stations available S U NA
15. The school principal is aware of his responsibility and liability in regard to students' protection S U NA
16. The school principal requires that the shop areas be maintained and cleaned, and provided with the same custodial services available to other general education programs. S U NA
17. The school principal will make sure that an industrial arts certified instructor is in attendance when student work takes place S U NA

18. A policy exists for dealing with the removal of students who consistently violate safety regulations. S U NA

B. INSTRUCTOR

1. Industrial arts teacher supervision is provided at all times when classes are in session S U NA
2. The instructor continuously inspects his facility to discover needed repairs and corrections. S U NA
3. The instructor utilizes an inspection checklist when making formal inspections and maintains file copies. S U NA
4. The instructor reports all hazardous conditions to the proper administrator S U NA
5. The instructor keeps records of all inspections and has copies of inspection reports readily available for reference S U NA
6. The instructor keeps records of all maintenance problems and the disposition of requests for corrections. S U NA
7. The instructor keeps records of all accidents, and analyzes them immediately for corrective measures S U NA
8. The instructor keeps records of all safety instruction and evaluation. S U NA
9. The instructor selects student activities, keeping in mind the maturation level and ability of the students involved S U NA
10. Instructor-owned tools are not used by students unless a district policy has been established to cover their use, and the school principal has been informed. S U NA
11. The instructor makes sure that students wear protective equipment when needed. S U NA
12. The instructor is responsible to see that personal protective equipment has been sterilized S U NA
13. Instruction is reinforced by continuous proper example through deeds and actions of the instructor, such as wearing protective equipment in all situations deemed necessary. S U NA
14. The instructor is knowledgeable in the use of the various fire extinguishers in his facility. . . . S U NA
15. When classes are not in session, the instructor makes sure that all main power switches are in the "off" position S U NA
16. The instructor makes sure that all machines are off and tagged when they are being cleaned or adjusted S U NA
17. A system for handling hot materials has been established. S U NA

15.01

203

Original—Teacher

1st Copy—Principal

2nd Copy—Central File

18. Routine preventative maintenance is practiced to assure against breakdown of equipment and safety protection devices. S U NA

C. INSTRUCTION

1. The student's sense of responsibility is promoted, developed and periodically evaluated S U NA
2. Students receive instruction in the use of all tools and equipment they are expected to operate S U NA
3. Students are tested and permission is granted before machines are operated. S U NA
4. Ground rules are established and enforced for safe, efficient shop operation. S U NA
5. Students are instructed and alerted to possible hazardous operations and are monitored in these activities S U NA
6. "Horseplay" and practical jokes are dangerous and are not tolerated S U NA
7. Proper instruction and warning are given in the use and handling of toxics, caustics and volatile materials. S U NA
8. In order to provide continuous safety instruction, questions on safety are included in all phases of the instructional program. S U NA
9. Students are instructed in the proper methods of handling and lifting materials. S U NA
10. Students are given the responsibility to see that they and other students are clear of machines when turning them on, never to leave a machine in a running position, or stop one with their hands or a piece of material. S U NA
11. Students are instructed to stay clear of others operating machines and, if necessary to approach an operator, to do so in such a manner not to annoy or alarm him/her S U NA
12. All work undertaken is approved through some established method before proceeding S U NA
13. Materials being worked are secured when the operation being conducted so demands S U NA
14. A class personnel organization is used including a student safety engineer S U NA
15. Safety bulletin boards, posters and student reports are part of the total safety program S U NA
16. Students are instructed as to how to report hazards and fires S U NA

D. PERSONNEL PROTECTION

1. In compliance with Pennsylvania Law, eye protection devices will be worn and appropriate signs posted. S U NA
2. Eye-wash baths and showers are available when using caustic materials S U NA

3. After use, eye-protective devices are cleaned and returned to properly designed storage racks. S U NA
4. In all areas needing special body-protective clothing, such clothing is provided and used. (Example: aprons, shoes, gloves) S U NA
5. In all areas needing respiration devices and noise suppression devices, such devices are provided and used S U NA
6. Students are cautioned on the danger of loose clothing, jewelry, ties, long hair, etc. (Regulations in regard to their dangers are enforced.) S U NA
7. All injuries are reported to the instructor for immediate attention. S U NA

E. GENERAL FACILITY

1. One instructor has the overall responsibility for each major shop facility. S U NA
2. Each major shop facility can be locked separately S U NA
3. Provision has been made for keeping inappropriate garments and other materials out of activity areas S U NA
4. Good housekeeping standards are observed. S U NA
5. The student educational cleanup program is backed up daily with complete custodial services S U NA
6. Waste (shavings, sawdust, paint, and oil rags) is collected daily and disposed of by the custodian. S U NA
7. Floors are maintained in a condition conducive to safe practices with nonskid surfaces provided around machines. S U NA
8. Designated safety zone areas are provided around all dangerous areas of work. S U NA
9. Aisles are clear of protruding materials S U NA
10. Room furniture and equipment are arranged for optimum safety S U NA
11. Nonflare lighting is provided for all work areas according to State Board of Health regulation S U NA
12. Stairways within existing laboratories have safe tread and rise with unobstructed access and with approved railings. S U NA
13. Railings and treads are color coded. S U NA
14. Two widely separate marked exits are available from each major laboratory area S U NA
15. Facilities are light, pleasant, clean and conducive to good instruction. S U NA
16. Machine operation regulations and safety procedures are posted conspicuously near areas of operation S U NA

17. Parts of machines and equipment needing special attention or caution are painted brightly with correct color code. S U NA
18. Machine and work stations are located in relationship to the amount of supervision required. S U NA
19. Machine location has been determined by needed operator space requirements and process compatibility. S U NA
20. Health hazards were considered in plant design to minimize injuries from excess heat, noise, fire and fume conditions. S U NA

F. STORAGE

1. Storage racks and shelves are designed and constructed to meet storage requirements . . . S U NA
2. Materials are stored in a safe manner. S U NA
3. Students and instructors are protected from protruding materials and sharp edges. S U NA
4. All flammable and combustible liquids, toxics and caustics are stored securely in proper containers, identified by name and degree of hazard. S U NA
5. Fire-approved storage cabinets are provided for all flammable and combustible liquids . . . S U NA
6. Provision has been made for a fire-approved bulk storage area. (Refer to local fire marshal) S U NA

G. ELECTRICAL

1. All power wiring is installed and maintained in accordance with national electric code and:
 - (a) switches are enclosed S U NA
 - (b) circuits are identified S U NA
 - (c) all power cords are of proper length as determined by gauge and load S U NA
 - (d) power supplies are provided with overload protection S U NA
 - (e) lockouts are provided. S U NA
2. All outlets and machines are grounded. S U NA
3. All extension cords are three-wire with proper connections S U NA
4. All portable power tools are provided with three-prong plugs, except those which are double insulated S U NA
5. Readily accessible individual "off" and "on" controls are installed on all machines as well as in the room power-control panel. S U NA
6. On machines where injury might result if motors were to restart after major power shutoff, provision is made to prevent such restarting. (Magnetic switches.) S U NA

7. A master-control "Panic Stop System" is available and conveniently located in each laboratory to shut off power S U NA
8. Each laboratory area has its own master-control switch and power panel located for easy access S U NA
9. Laboratory power panels have clearly identified individual power switches for each machine. S U NA
10. Extension cords are not used for permanent installation. S U NA
11. All hand-held portable power tools are equipped with "dead man" controls only S U NA
12. Regulator, stands and pilot lights are provided for all electrical soldering irons. S U NA
13. All electrical apparatus in areas of concentrated vapors are vapor proof. S U NA

H. EQUIPMENT

1. Safety instructions for the use of each machine is posted S U NA
2. Machines are in safe operating condition at all times. S U NA
3. "Out-of-order" signs are secured to machines not in working order and power panel switch is in "off" position S U NA
4. All machines are securely fastened in place according to good industrial practice. U NA
5. Machines and equipment are provided with guards meeting industrial standards and guards are in proper position for safe machine operation. S U NA

Items requiring special consideration are: . . .

- (a) squaring shears finger guard. S U NA
- (b) foot treadle stops on squaring shears. . . S U NA
- (c) jointer knife guards-left and right S U NA
- (d) abrasive wheel safety eye shields. S U NA
- (e) abrasive wheel foot rests S U NA
- (f) abrasive wheel guards. S U NA
- (g) table saw guard including anti-kickback S U NA
- (h) radial saw guard S U NA
- (i) radial saw forward stop and positive saw return S U NA
- (j) radial saw anti-kickback device. S U NA
- (k) machine belt and pulley guards S U NA
- (l) air compressor belt guards. S U NA

(m) compressed air is not used for cleaning purposes until it has been reduced to less than 30 p.s.i. S U NA

(n) compressed air is not used for cleaning purposes where possibility of eye injury exists S U NA

6. Equipment control switches are readily accessible to the operator while he/she is in a normal operating position S U NA

7. A positive "off" position switch is located on each machine S U NA

8. Proper tools and materials are available for machine cleaning S U NA

9. Hand-tool equipment is stored with sharp cutting edges protected S U NA

10. Hand tools are properly maintained and kept sharp S U NA

11. Bench tops are in keeping with the activities planned (Example: electrical bench tops are made of non-conductive materials) S U NA

12. Properly designed and constructed auto stands and roll blocks are used. (A sufficient supply is available to meet the needs of the power mechanics areas.) S U NA

13. Engine stands are properly designed and constructed S U NA

14. All hoists and A-frames are properly constructed, designed for the job undertaken, labeled as to capacity and fitted with a safety block S U NA

I. FIRE

1. When available, only U.L. approved equipment will be used S U NA

2. A sufficient number of proper fire extinguishers (periodically inspected, dated, and recharged) is readily accessible in all activity areas S U NA

3. A wool fire blanket is available for clothing fire. (Special caution should be taken with polyester clothing.) S U NA

4. Area behind fire extinguisher is color coded S U NA

5. Extinguishers are hung at approved heights S U NA

6. Adequate exit doors and open aisles are available for prompt evacuation S U NA

7. Fire-approved (U.L.-FM) storage and waste containers are readily accessible, used and emptied daily S U NA

8. Parts (solvent) wash tanks are fire fused S U NA

9. Finish and spray room doors swing out and cannot be locked from the inside S U NA

10. Filters in spray booths are replaced regularly S U NA

J. WELDING

1. Proper protective clothing is worn when needed S U NA

2. Goggles with the proper lenses are used when torch welding S U NA

3. An arc-welding helmet with correct lenses is used when electric welding (Min. Shade #12-MIG & TIG) (Min. Shade #10-STD. ARC) S U NA

4. Observers use acceptable protection S U NA

5. Welding is done only in areas free of combustible materials S U NA

6. Cylinders are secured up-right, clear of passageways, and stored in ventilated areas S U NA

7. Extra cylinders are properly stored, meeting regulations of the Pennsylvania Department of Labor and Industry S U NA

8. Gas pipelines have been installed and are maintained according to code S U NA

9. Pipelines are checked each year by persons knowledgeable with code requirements S U NA

10. Piped welding systems will have back pressure valves in both lines and conveniently located shutoff valves which will not be quick opening S U NA

11. Torches and regulators are clean, well maintained, and in good operating condition S U NA

12. Hoses are maintained in good condition S U NA

13. Only spark lighters are used to light torches S U NA

14. Anti-fire flashbacks are installed where required in all hoses and lines S U NA

15. The welding area is located in such a manner that an arc cannot be struck on (gas) cylinders, gas lines or water lines S U NA

16. Reflective screens are provided and used to protect others from arc flashes and burns S U NA

17. When items to be welded will not fit into screened area, all persons near area will be provided proper protective equipment S U NA

18. Arc welding is done in dry areas only S U NA

19. The electrode holder is maintained and stored in good condition to eliminate possible accidental arcs S U NA

20. Proper ventilation is provided S U NA

K. GAS

1. Gas-operated equipment is ignited from an automatic ignition system or pilot light S U NA

2. The main supply cutoff valve is identified, is readily accessible, and is located outside possible heat or fire areas S U NA

3. Gas equipment is provided with a shutoff valve and a safety system. (Example: spark ignition, gas pressure regulator, safety gas check valve, etc.) S U NA

TEACHER LIABILITY IN SCHOOL SHOP ACCIDENTS

As in industry and commerce, the possibility of accidental injury is a specter that haunts us in public education. This manual has been prepared in the hope of lessening the frequency and severity of injury to students by providing advice on safe practices for use in industrial arts classrooms and labs. For a number of reasons as complex as human beings themselves, it will be impossible to eliminate accidents entirely from industrial arts activities. It is with this knowledge that the following section has been prepared for your information. It describes the rights and duties of teachers, their supervisory responsibilities, and the degree of liability that they may be subject to when an accident occurs.

Teachers must in many situations exercise greater care to prevent injuries to their students than an ordinarily reasonable and prudent person may be expected to exercise. This occurs partly because the Pennsylvania School Code provides that teachers stand "in loco parentis" (in place of the parent) and are personally liable for acts of negligence while performing their duties as a teacher. Set forth below is Section 1317 of the School Code from which this authority stems.

Sch. 1317 AUTHORITY OF TEACHERS, VICE PRINCIPALS AND PRINCIPALS OVER PUPILS

Every teacher, vice principal and principal in the public schools shall have the right to exercise the same authority as to conduct and behavior over the pupils attending his school, during the time they are in attendance, including the time required in going to and from their homes, as the parents, guardians or persons in parental relation to such pupils may exercise over them.

An act of negligence may be one directly committed by a teacher such as operating a piece of equipment during a demonstration without all safety devices in full functioning order and thereby injuring a student; or, negligence may be the failure to adequately supervise students during class activities or the omission of complete and thorough instruction in correct safety procedures for a given assignment. Either way, by omitting or committing an action a teacher may be negligent.

The occurrence of a negligent act may give rise to a court proceeding for the purpose of establishing the liability of the teacher for any resultant injury. However, negligence may not be a sufficient reason for a finding of liability where the careless act is not a substantial factor in the injury or where the injury is an act of God. Liability is the legal conclusion that a negligent act was a major factor in causing an injury. A note of caution: exposure to liability is increased by industrial arts personnel because the teaching of safe practices is an integral part of the curriculum.

It has already been stated that Section 1317 of the School Code imposes heavy responsibility on teachers. Section 320 of the Restatement of Torts goes even further:

**DUTY OF PERSON HAVING CUSTODY OF ANOTHER
TO CONTROL CONDUCT OF THIRD PERSONS**

One who is required by law to take or who voluntarily takes the custody of another under circumstances such as to deprive the other of his normal power of self-protection or to subject him to association with persons likely to harm him is under a duty to exercise reasonable care so to control the conduct of third persons as to prevent them from intentionally harming the other or so conducting themselves as to create an unreasonable risk of harm to him if the actor:

- (a) knows or has reason to know that he has the ability to control the conduct of third persons, and
- (b) knows or should know of the necessity and opportunity for exercising such control.

Obviously, the two statutory provisions cited potentially give rise to many situations in any school day where a teacher may be unconsciously negligent. This can only be interpreted as a clear mandate for thorough and complete concentration on the job of teaching during student contact hours. Anything less than this can carry heavy penalties.

The following are a few general recommendations to avoid negligent acts:

1. Supervise students to prevent them from injury to themselves or from injury caused by others.
2. Instruct students in proper manner of conducting inherently dangerous activities. Emphasize and periodically review all safety procedures.
3. Warn students of the specific dangers inherent in each classroom activity.
4. Keep machinery in proper working order especially its safety devices. If a machine is defective, do not use it and render it inoperable if possible.
5. Use discretion in the selection of participants for activities not under direct personal supervision.

Another section of the School Code that is pertinent to this discussion is Section 510.

16.01

Sch. 510 RULES AND REGULATIONS

The board of school directors in any school district may adopt and enforce such reasonable rules and regulations as it may deem necessary and proper, regarding the management of its school affairs and the conduct and deportment of all superintendents, teachers, and other appointees or employes during the time they are engaged in their duties to the district, as well as regarding the conduct and deportment of all pupils attending the public schools in the district, during such time as they are under the supervision of the board of school directors and teachers, including the time necessarily spent in coming to and returning from school.

Teachers have this additional responsibility to enforce local policies and regulations adopted pursuant to this section. Familiarity with such policies as they pertain to the industrial arts areas and the school district in general is imperative. Where a teacher is unaware of a rule, regulation, or policy governing his or his students' behavior and an accident occurs where ignorance of a rule pertinent to the behavior that resulted in the accident can be shown, the teacher has greatly increased his liability.

What are the consequences of liability for student injury? The first one that occurs to most persons is financial. The size of a financial settlement in a liability claim is generally dictated by the extent of any disability sustained and compensation for its consequent pain and suffering. A broken arm will heal in relatively short time with a minimum of discomfort and inconvenience. A reasonable settlement might be the cost of treatment and some compensation for the period of disability. Where the disability will be lifelong and may result in a loss of potential earning power as in the loss of a limb or vision, the settlement may easily run to hundreds of thousands of dollars.

A teacher who is found to be liable in a major accident has probably failed to practice his profession in such a way as to meet the expectations of his employer and society. The consequences for this may not end with a financial settlement with the victim.

Sch. 1122 CAUSES FOR TERMINATION OF CONTRACT

The only valid causes for termination of a contract heretofore or hereafter entered into with a professional employe shall be immorality, incompetency, intemperance, cruelty, persistent negligence, mental derangement, advocacy of or participating in un-American or subversive doctrines, persistent and willful violation of the school laws of this Commonwealth on the part of the professional employe:

At least four charges may be brought against the hapless teacher at this point: incompetency, intemperance, persistent negligence and persistent and willful violation of the school laws. Real concern should be given to the fact that these charges may be brought prior to any

judicial determination of liability or following the judicial dismissal of a liability claim. Note that section 1122 does not concern itself with the question of liability; it is concerned with the expected conduct of a professional employee.

If the 1122 charges are sustained and the employee is dismissed the terrible tide of retribution may continue to roll even further.

SCH #1211 ANNULMENT OF CERTIFICATES

All State certificates or endorsements of the certificates of other states may be annulled by the Superintendent of Public Instruction for incompetency, cruelty, negligence, immorality or intemperance, after hearing, of which reasonable notice in writing must be given to the parties interested.

Incorporation of this discussion in this manual is not done for the purpose of intimidating teachers, it is here to clearly set out the responsibilities that they have to clearly explain the consequences of failing to fulfill those responsibilities.

There are some steps with which every teacher should be familiar to lessen the possibility of an unwarranted finding of liability when an accident occurs.

1. Report all injuries to your building administrator in writing with all details including a full description of the accident, time, place, names of injured persons, and names of any witnesses.
2. Have all injuries regardless of severity examined by the school nurse.
3. Notify the appropriate person wherever a local teacher organization has liability protection for you.
4. Know and follow all local procedures for the reporting of injuries.

Protect yourself - all information and notification of an accident should originate from you.

SHOP PRACTICES LEADING TO LIABILITY OF INSTRUCTORS

Shop Practice

Absence of the teacher from the shop when students are working therein.

Teachers leaving the shop under the supervision of a teacher who is not qualified to teach shop work.

Permitting students not enrolled in the class to use shop equipment and tools.

Administrative practices and instructional activities designed to eliminate such practice as a factor in teacher liability.

1. Never absent yourself from the shop while students are working in the shop.
 2. Have a clear understanding with your principal and/or supervisor that you are not to be called from the shop during a class session.
 3. Only under extreme necessity should an instructor absent himself from the shop. When this occurs, lock the main switch box and provide a sedentary or reading assignment to students during your absence.
-
1. Teachers are liable to be absent for a period of time due to illness or attending a teachers meeting or conference. It is the practice of school administrators to staff the shop with most any instructor, providing he has a free hour available.
 2. Do not permit a substitute teacher in your shop unless he is a qualified or certified instructor.
 3. If none is available, prepare written or reading assignments in advance, or some type of sedentary activity where they will not be utilizing the machines and equipment in the shop. Instructional movies or similar aids are practical if they fit into the instructional program.
-
1. Permit only those students who have participated in your shop program or who are participating to use the shop and equipment therein.

Permitting students to use machines or tools or to perform activities for which instruction has not been given.

Pupils using equipment in the shop which has not been approved by the administration and board of education.

Permitting students to work in the shop free periods, particularly when the shop is not supervised.

Permitting students to use dull tools and/or cutting devices on machines.

2. No exceptions should be made to this practice.
3. Do not take the word of a student that he has had previous instruction on the tool or has had experience in their use.
1. Make sure that proper instruction is given relative to each basic operation to be performed by a student in the shop class.
2. Permit no student to utilize a machine or tool in performing an operation for which instruction has not been given.
3. Keep an accurate instructional log as to those materials, machines and tools and operations pertaining thereto in which instruction has been given.
1. Allow no student to bring in any item of equipment for use in the shop.
2. Permit students to use only those items of tools and machines that have been purchased with the approval of the Board of Education and School Administration.
1. Do not be absent from your shop when students are working, even during unscheduled classes or periods.
2. Permit students to utilize equipment and work in the shop during designated periods when proper supervision is given.
1. Periodically inspect all cutting edges of power tool devices and hand tools.
2. Keep all items of equipment properly maintained and sharpened.

213

Permitting students to perform operations on machines without guard particularly when one could have been used.

3. Demonstrate the proper maintenance and care of cutting edges of safe hand tools, particularly those jobs within the ability of the student to perform.
1. Provide proper instruction as to the use and adjustment of guards emphasizing the necessity and functions of such a device.
2. Set an example yourself, by using guards and safety devices at all times, and perform operations as you would want them performed by students.
3. Require that students use guards at all times on machines when such devices can be used.
4. Have students secure permission to use any item of equipment. This will permit you to check on the machines to see that all guards and safety devices are properly adjusted.

Allowing use of equipment by students who are prone to accidents or who possess physical abnormalities that may cause an accident.

1. Be familiar with the work habits of students and with those who possess physical abnormalities which may necessitate restrictions being placed on their use of equipment.
2. Require all students to secure permission before the use of any item of equipment.
3. Limit such students to the use of machines which are within their capabilities and commensurate with whatever physical abnormalities they possess.

Sending pupils outside the shop to perform activities for the school or other departments.

1. Do not permit any students to leave the shop to perform activities outside the department.
2. Refuse to undertake projects or jobs that require the student to work away from the shop without your continuous supervision.

Failure to keep accurate written reports relative to accidents.

3. Confine instructional and maintenance activities to those that can be performed in the shop.
1. Prepare an accident form for your shop if the school system does not have a standard form.
2. Fill out the form as soon after the accident has taken place. Make multiple copies and keep one for yourself.

Failure to secure written statement from witnesses to shop accidents.

1. Provide a place on your accident report form for the listing of witnesses.
2. Have witnesses write, in their own words, their views as to how the accident happened.
3. Have witnesses sign their signature to their statement.

Failure to administer safety tests to students in case of liable suit for negligence.

1. Administer safety tests to students upon completion of the demonstration of a specific machine, tool or process.
2. Keep tests on file in your office as evidence that such material has been covered and that a test was actually administered over material.
3. Set a critical score above which students must achieve in order to utilize a specific item of equipment. Many instructors demand a "perfect paper" prior to letting students use such equipment.

Failure of the teacher to exercise the utmost of caution.

1. The teacher MUST anticipate where and how an accident will occur, and utilize every means to eliminate the possibility of an accident occurring.
2. Make every possible effort to provide the safest possible physical facilities, and implement an effective safety instructional program.

Contributory Negligence

The term "contributory negligence" can be interpreted in a very broad sense. However, the following suggestions are given with a view in mind of eliminating the possibility of a teacher being charged with "contributory negligence:"

1. Maintain the safest of working conditions in the shop.
2. Insist on safe practices being adhered to at all times in the shop.
3. Provide complete and proper instruction in all aspects of shop work, with regard to the use of tools, machines and materials.
4. Make recommendations to superiors as to improvements that can be made to improve safety conditions in the shop.
5. Make improvements suggested by your superiors.
6. Establish safety rules and enforce them.
7. Organize and implement a "complete" and continuous safety education program.

Failure to effectively administer a comprehensive eye safety program.

1. Be familiar with and conversant about eye safety legislation.
2. Require all students to wear eye protection devices at all times for laboratory activities.
3. Know the appropriate eye safety device for each operation.
4. Set an example yourself by always wearing the appropriate eye protection devices.

SELECTED BIBLIOGRAPHY

- American Council of Industrial Arts Supervisors. Guide To Preparing Educational Specifications For Secondary Industrial Arts Facilities. Washington, D.C., 1974.
- American Vocational Association and National Safety Council Joint Safety Committee. Let's Teach Safety, A Dictionary of Classroom Resources. Arlington, VA: American Vocational Association, Inc., 1980.
- Best's Safety Directory. Edited by Nancy S. Baxter.. Oldwick, N.J., 1980.
- Brown, Robert D. Industrial Education Facilities. Boston, MA: Allyn and Bacon, Inc., 1969.
- "Catalog Number 776". Philadelphia, PA: General Scientific Equipment Co., 1976.
- Godbey, Frank W. Occupational Safety and Health in Vocational Education - A Guide For Administrators, Faculty and Staff. DHEW (NIOSH) No. 79-125. Cincinnati, Ohio, 1979.
- Hand Tool Institute. Hand Tool Safety - Guide to Selection and Proper Use. White Plains, N.Y., 1976.
- Hoerner, T.A. and Bettis, M.D. Power Tool Safety and Operation. St. Paul, Minnesota: Hobar Publications, 1977.
- Jacobs, Clinton I. and Turner, J. Howard. Developing Safety Skills. Athens, GA: American Association for Vocational Instructional Materials (AAVIM), 1979.
- Kigin, Denis J. Teacher Liability in School Shop Accidents. Ann Arbor, Michigan: Prakken Publications, 1973.
- Mincemoyer, Donald L., Williams, William, and Curtis, Samuel M. Safe Power Shop Equipment Operation. State College, PA: Department of Agriculture Education, College of Agriculture, The Pennsylvania State University, 1974.
- Modern School Shop Planning. 7th ed., rev., Ann Arbor, Michigan: Prakken Publications, 1976.
- Notgrass, Troy. Safety Handbook for ICT. Austin, TX: Instructional Materials Center, Division of Continuing Education, The University of Texas at Austin, 1978.
- Occupational Safety and Health Standards for General Industry. Chicago: Commerce Clearing House, Inc. 1979.

17.00

Bibliography

State of Ohio, Industrial Arts and Vocational Education Safety Manual.
Columbus, Ohio: State of Ohio, Department of Education, Industrial
Commission of Ohio, Division of Safety and Hygiene, n.d.

Strong, Merle E., Editor. Accident Prevention Manual for Training
Programs. Chicago, IL: American Technical Society, 1975.

U.S. Department of Labor, Occupational Safety and Health Administration.
All About OSHA. OSHA 2056, Washington, D.C., 1976.

U.S. Department of Labor, Occupational Safety and Health Administration.
Principles and Techniques of Mechanical Guarding. Washington,
D.C., 1971.

U.S. Congress. Occupational Safety and Health Act of 1970. Public
Law 91-596. 91st Congress, 1970.

Wahl, Ray. Safety and Health Guide for Vocational Educators. Vol. 15,
No. 1, Harrisburg, PA: Pennsylvania Department of Education, 1977.

Washington State Industrial Arts Safety Guide. Olympia, Washington:
State of Washington Department of Education, 1976.

A

ACCIDENT REPORTS

- Administrator. 2.03
- Analysis 4.05
- Follow-up procedures 4.01
- Sample Form. 4.06
- Teacher. 2.05

ACID SPILLS

- Storage Batteries.10.03

ADMINISTRATOR

- Principal or dept. head. . 2.01

- AIR BRUSH11.02

- AIR IMPACT WRENCH, PORTABLE . 12.84

AISLES

See Traffic Aisles

- AMMONIA FUMES11.00

- ANNULMENT OF CERTIFICATE. . . 16.03

- ARC WELDER.12.06

- ASBESTOS. 7.00, 9.03

B

BAND SAW

- Horizontal12.30
- Vertical12.08

- BAYONETTE SAW12.86

- BELT FINISHING MACHINE. . . . 12.10

- BELT SANDER, PORTABLE 12.88

- BUFFER.12.12

C

- CATHODE RAY TUBES10.01

- CIRCULAR SAW.12.14
- Portable12.92

- CLASS SIZE. 2.03

- COLOR 14.04, 14.05

COMPREHENSIVE SAFETY

- PROGRAM. 2.00, 2.02, 2.04

- COMPRESSED GAS. 9.00

- COMBUSTIBLE METALS. 9.02

- CONSTRUCTION PROCESSES. . . 9.00, 9.01

- CONTACT LENSES. 13.01, 13.03

- CORRECTIVE LENSES13.01

- CRUCIBLE FURNACE.12.16

D

DEPARTMENT HEAD

- RESPONSIBILITY 2.01

- DELUGE SHOWERS.12.109

DISADVANTAGED STUDENTS

- Suggested Techniques 5.00

- DISC FINISHING MACHINE. . . . 12.18

- DISC SANDER, PORTABLE 12.90

- DRAFTING ROOM11.00

- Paper Cutter11.00

- Printers & Developers. . . 11.00

- DRILL PRESS12.20

DRIVING AND LOCATING A

- VEHICLE FOR WORK10.02

- DRY MOUNT11.01

- DUST. 9.02, 14.04

E

ELECTRICAL SAFETY . . . 12.105-12.108

- Defective Equipment. . . . 12.106

- Unsafe Practice.12.106

- Lack of Knowledge.12.107

- Ground Fault Protection. . 12.107

- ELECTRIC DISCHARGE MACHINE . 12.22

- ELECTRIC DRILL, PORTABLE. . . 12.94

Index

ELEMENTARY INDUSTRIAL ARTS. . . 6.00

EMERGENCY ACTION.4.00-4.06

- Primary Concern. 4.00
- Follow-up Procedures 4.01
- Emergency Communication. . . 4.02
- Accident Reporting 4.05
- Accident Report Form 4.06

ENGRAVING11.03

EYE PROTECTION.13.01-13.07

- Corrective Lenses.13.01
- Sanitation Facilities.13.02
- Types of Hazards13.02
- Welding Lenses13.03
- Contact Lenses . . . 13.01, 13.03
- Selection Chart.13.04
- Lesson Plan.13.05
- The Law--Act 11613.07
- Eye Safety Liability16.08

F

FACILITIES. 2.03, 2.05

FACILITY PLANNING14.00-14.07

- Safety Zones14.01
- Traffic Aisles14.01
- Magnetic Starters.14.02
- Panic Buttons.14.02
- Space Recommendations. . . .14.02
- Aisles14.03
- Ventilation.14.03
- Lighting14.03
- Storage14.03
- Special Needs.14.03
- Noise.14.04
- Dust14.04
- Color.14.04
- Signs.14.05

FINISHING SANDER, PORTABLE. . .12.96

FIRST AID 4.00

FIRE BLANKET.12.109

FIRE EXTINGUISHER

- Chart.12.111
- Combustible Liquids. 9.03
- Inspection12.108
- Special Needs.14.03
- Symbols.12.110

Fire Extinguisher (Continued)

- Type12.108
- Wood 9.09

FIRE SAFETY

- Deluge Showers12.109
- Fire Blanket12.109
- Fire Extinguishers12.108
- Oily Waste Storage12.109

FLAMMABLE COMBUSTIBLE LIQUIDS . 9.03

- Industrial Materials 9.03
- Power Technology . . .04-10.06
- Fire Safety.12.108

FOLDING MACHINE11.02

FOUNDRY 9.05

FUMES7.01,7.02, 9.02

FUNDING 2.00

G

GAS CHARACTERISTICS 9.01

GAS FORGE12.26

GENERAL METALWORKING. . . .9.06-9.08

GENERAL SAFETY FOR ALL AREAS
OF INDUSTRIAL ARTS12.02

GRAPHIC ARTS.11.00-11.03

- Dark Room.11.00
- Dry Mount.11.01
- Process Camera11.01
- Stripping Table.11.02
- Folding Machine.11.02
- Plate Maker.11.02
- Paper Drill.11.02
- Air Brush.11.02
- Sign Press11.02
- Engraving.11.03
- Thermography11.03
- Rubber Stamp & Gold
Stamping11.03

GREASE, OILS, FUELS, &
SOLVENTS10.02

GRINDER12.28

GOLD STAMPING11.03
 GROUND FAULT PROTECTION12.107
 GUARDING. 8.00

H

HANDICAPPED STUDENTS
 Suggested Techniques. 5.01-5.02
 HAND TOOL SAFETY.12.102
 HAZARDOUS CONDITIONS REPORT . . 4.04
 HAZARDOUS MATERIALS 7.00
 HAZARDS FROM BATTERIES.10.03
 HEARING13.08-13.10
 Maximum Noise Levels. . . 13.08
 Hearing Protection
 Devices13.09
 Selected Noise Sources;
 Chart13.10
 Noise Standards.14.04
 HEARING PROTECTION DEVICES. . .13.09
 14.04
 HORIZONTAL MILLING MACHINE. . .12.32
 HOUSEKEEPING.12.103
 HYDRAULIC TRAINING KIT.12.24

I

INDUSTRIAL MATERIALS. . . .9.00-9.10
 Compressed Gas 9.00
 Construction Processes . . .9.00
 Dust, Fumes, &
 Combustible Metals. . . 9.02
 Flammable & Combustible
 Liquids 9.03
 Foundry. 9.05
 General Metalworking . . . 9.06
 Plastics 9.07
 Soldering. 9.08
 Wood 9.09
 INFORMATION SHEETS. . . .12.05-12.101

"IN LOCO PARENTIS".16.00
 IN-SERVICE TRAINING2.00-2.02
 INSPECTION CHECK LIST . .15.00-15.05

INSTRUCTIONAL TECHNIQUES.12.00-12.111
 Safety Inspections12.01
 All Areas of
 Industrial Arts . . .12.02
 Care & Operation of
 Equipment12.03
 Housekeeping12.103
 Materials Handling12.104
 Electrical Safety.12.105
 Fire Safety.12.108

J

JOINTER12.34

L

LAW
 Act 116--Eye Safety. . . .13.07
 OSHA 3.02
 Pennsylvania Safety. . . . 3.00
 Section 504. 5.00

LESSON PLAN FOR EYE SAFETY. . .13.05

LIABILITY
 See Teacher Liability

LIABILITY INSURANCE 2.00

LIFTING
 Instructional Techniques .12.00
 Materials Handling12.104
 Back Strains for Proper
 Lifting13.11
 Lifting Chart.13.13

LIFTING CHART13.13

LIGHTING.14.03

M

MACHINE GUARDING. 8.00
 OSHA Requirements. 8.00

MAGNETIC STARTERS14.02

MATERIALS HANDLING12.104
 MAXIMUM NOISE LEVELS13.08
 Noise Exposure Table . . .13.08
 Selected Noise Sources;
 Chart13.10
 METAL LATHE12.36
 METAL SHAPER12.38
 MIG WELDER12.72
 MILLING MACHINE
 Horizontal12.32
 Vertical12.76
 MOTORIZED MITER BOX12.40

N

NEGLIGENCE16.00, 16.01
 Contributory Negligence .16.07
 NOISE14.03, 14.04
 NOISE SOURCES - CHART13.10

O

OILY WASTE STORAGE12.108
 OSHA3.02
 OFFSET PRINTING PRESS12.42
 OVERARM ROUTER12.44
 OXY-ACETYLENE WELDER12.46

P

PANIC BUTTON14.02
 PAPER CUTTER11.00, 12.48
 PAPER DRILL11.02, 12.50
 PENNSYLVANIA SAFETY LAW3.00
 PENNSYLVANIA SCHOOL CODE.16.00-16.03

Section 1317, "In
 Loco Parentis". . . .16.00

Section 320, Restatement
 of Torts16.01
 Section 510, Rules and
 Regulations16.02
 Section 1122, Termination
 of Contract . .16.02-16.03
 Section 1211, Annulment
 of Certificate16.03

PERMISSION SLIPS4.02
 Sample Form4.03
 PERSONAL PROTECTION . . .13.00-13.13
 Head13.00
 Eye-Face13.01-13.07
 Respiratory13.11-13.12
 Body Protection13.00
 Hearing . . .13.08-13.10,14.00
 Lifting13.11-13.13

PLANER12.52

PLANE, PORTABLE ELECTRIC . . .12.98

PLASTICS9.07, 12.54

PLASTICS TECHNOLOGY12.54

PLATE MAKER11.02

PLATEN PRINTING PRESS12.56

POLICY STATEMENT ON SAFETY
 IMPLEMENTATION1.05

PORTABLE POWER TOOLS . . .12.82-12.101

POWER TECHNOLOGY10.00-10.06
 Cathode Ray Tubes10.01
 Driving & Locating a
 Vehicle for Work . . .10.02
 General Precautions . . .10.00
 Flammable & Combustible
 Liquids10.04
 Grease, Oils, Fuels,
 and Solvents10.02
 Hydraulic Training Unit .12.24
 Personal Health
 Considerations10.01
 Storage Batteries10.03

PRINCIPAL RESPONSIBILITY2.01

PRINTERS AND DEVELOPERS11.00

PROCESS CAMERA.	11.01	SAFETY ZONES.	14.01
PROTECTIVE CLOTHING FOR HANDLING BATTERIES	10.03	SCROLL SAW.	12.60
R		SELECTION CHART FOR EYE AND FACE PROTECTION.	13.04
RADIAL ARM SAW.	12.58	SHEET METAL MACHINES.	12.62
RESPIRATORY PROTECTION. 13.11, 13.12 Respiratory Protection Chart	13.12	SIGN CHART.	14.08
RESPIRATORY PROTECTION CHART. .13.12		SIGN PRESS.	11.02
RESPONSIBILITY.	2.00-2.05	SIGNS, SAFETY	14.05
School Board and Superintendent	2.00	SIGN SELECTOR GUIDE	14.07
Safety Coordinator	2.00, 2.01	SHOP PRACTICES LEADING TO LIABILITY OF INSTRUCTORS.	16.04-16.08
Administrator-Principal of Dept. Head	2.01	SMALL ENGINE ANALYZER	12.64
Teacher.	2.04	SPACE RECOMMENDATIONS	14.02
Eye Protection	13.01	SPECIAL NEEDS, STUDENTS . .5.00-5.03	
ROUTER, PORTABLE.	12.100	SPINNING LATHE.	12.66
RUBBER STAMP.	11.03	SQUARING SHEARS	12.68
S		STANDARDS See Facility Planning	
SAFE PRACTICES IN THE CARE & OPERATION OF EQUIPMENT . .12.03		STAPLER	12.70
SAFETY COMMITTEES	2.01	STITCHER.	12.70
Instructional Technique. .12.00		STORAGE	14.03
Safety Inspection.	12.01	STORAGE BATTERY	10.03
SAFETY COORDINATOR.	2.00	STRIPPING TABLE	11.01
Responsibilities	2.01	SUPERVISION	
SAFETY INSPECTIONS.	2.01, 12.01	Teacher.	2.05
Inspection Check List. . .15.00		Administrator.	2.02
SAFETY LAWS	3.00	SURFACER.	12.52
SAFETY RULES FOR HAND TOOLS . .12.102		T	
SAFETY RULES FOR POWER EQUIPMENT.	12.05-12.101	TEACHER	
SAFETY SIGNS.	14.05	Responsibility	2.04
SAFETY TESTS.	16.07	Emergency Action	4.00
		Follow-up Procedure.	4.01

TEACHER LIABILITY16.00-16.08
 "In Loco Parentis"16.00
 Negligence16.00
 Pennsylvania School Code
 16.00, 16.01, 16.03
 Termination of Contract
 16.02, 16.03
 Shop Practices Leading
 to Liability. .16.04-16.08

TERMINATION OF CONTRACT16.02

THERMOGRAPHY.11.03

TOOLS FROM HOME16.05

TIG WELDER.12.72

TRAFFIC AISLES.14.01

U

UNIPLANE.12.74

UNQUALIFIED PERSONNEL16.04

V

VENTILATION

 Combustible Liquids.9.02
 Dark Room.11.00
 Engine Exhaust10.02
 Printers & Developers. . .11.00
 Standards.14.03
 Storage Batteries.10.02

VISUAL COMMUNICATIONS . .11.00-11.03

 Drafting Room.11.00
 Graphic Arts11.00

W

WELDING LENSES.13.03

WOOD.9.09

WOOD LATHE.12.78

WOOD SHAPER12.80

Z

ZINC OXIDE FUMES.7.02

224